

# LOW & MEDIUM PRESSURE FILTERS

INSTALLATION,  
SERVICE AND  
MAINTENANCE  
MANUAL  
AND SAFETY  
INSTRUCTIONS

## LFEX110

ELIXIR®



EN



PASSION  PERFORM





# TABLE OF CONTENTS

	Page
<b>1. Description</b>	2
<b>2. General warnings</b>	2
<b>3. Tools</b>	2
<b>4. Handling</b>	3
<b>5. Dimensional drawings</b>	4
<b>6. Installation</b>	5
<b>7. Commissioning</b>	5
<b>8. Standard maintenance</b>	6
8.1 Filter element replacement	6
<b>9. Special maintenance</b>	7
9.1 Clogging indicator (or plug) replacement	7
9.2 Seals replacement	8
<b>10. Instructions for use in explosive atmospheres</b>	10
<b>11. Regulations</b>	10
<b>12. Spare parts list</b>	11
<b>13. Ordering code</b>	12
13.1 Filter / Housing	12
13.2 Filter element	13
<b>14. Troubleshooting</b>	14
14.1 Misuse of the product	14
14.2 Clogging indicator alarm	14
14.3 Leaks of working fluid	14
<b>15. End-of-Life and Product Disposal</b>	15
15.1 Disassembly	15
15.2 Waste Classification	15
15.3 Environmental Recommendations	15



Please scan the QR codes to get updated electronic version of the related document.



Scan or click me!

## 1. Description

The hydraulic filters are components used to remove the contaminants from the hydraulic fluids used in the hydraulic systems, maximum pressure up to 16 bar, flow rate up to 300 l/min.

## 2. General warnings

- Before the installation, use or maintenance of the filter carefully read the manual
- The system and the filter are pressurised! Be sure the system is at ambient pressure before starting any activity
- The fluid temperature inside the system and the filter can cause injuries to personnel or create a hazardous environment
- Any activity must be carried out by trained and certified specialists, they must use the correct protective equipment
- Any activity must be carried out using the correct tool
- Any activity must be carried out in accordance with the laws in force in the country where the system is in operation
- The data shown onto the nameplate must be complete and legible during the whole filter working life
- Connect the filter with an anti-loosening system and regularly check the condition of the connection
- The declared performances and the safety of the product are only guaranteed when MP Filtri original spare parts are used
- Warranty is only effective if MP Filtri original spare parts are used.

## 3. Tools

LFEX110	TOOL	TIGHTENING TORQUE
Differential pressure indicator	Wrench A/F 19	20 N·m
Bowl	Wrench A/F 32	35 N·m
Connection G 1	Wrench A/F 41	Max 110 N·m
Connection 1-11.5 NPT	Wrench A/F 41	Max 95 N·m
Connection 1 5/16 - 12 (SAE 16)	Wrench A/F 41	Max 110 N·m
Connection G 1 1/4	Wrench A/F 50	Max 170 N·m
Connection 1 1/4-11.5 NPT	Wrench A/F 46	Max 125 N·m
Connection 1 5/8 - 12 (SAE 20)	Wrench A/F 1 7/8"	Max 210 N·m
Fastening screws M8	Socket wrench A/F 13	20 N·m
Fastening screws 5/16-18 UNC	Socket wrench A/F 1/2	20 N·m

## 4. Handling

- The unit is shipped in a cardboard box with dimensions depending on the order
- The handling must be carried out in accordance with the laws in force in the country of use of the product
- Handle the product with care, avoid impacts
- Store in a dry and frost-free room
- The unit should be stored in a suitable location away from the production area when not in use.  
The unit should be stored with the caps provided on the ports and the bowl's protective net, if present.  
This location should not impede any other production or personnel

Please refer to the following Weight table:

SERIES AND SIZE	WEIGHTS [kg]
LFEX110	1.90

## 5. Dimensional drawings

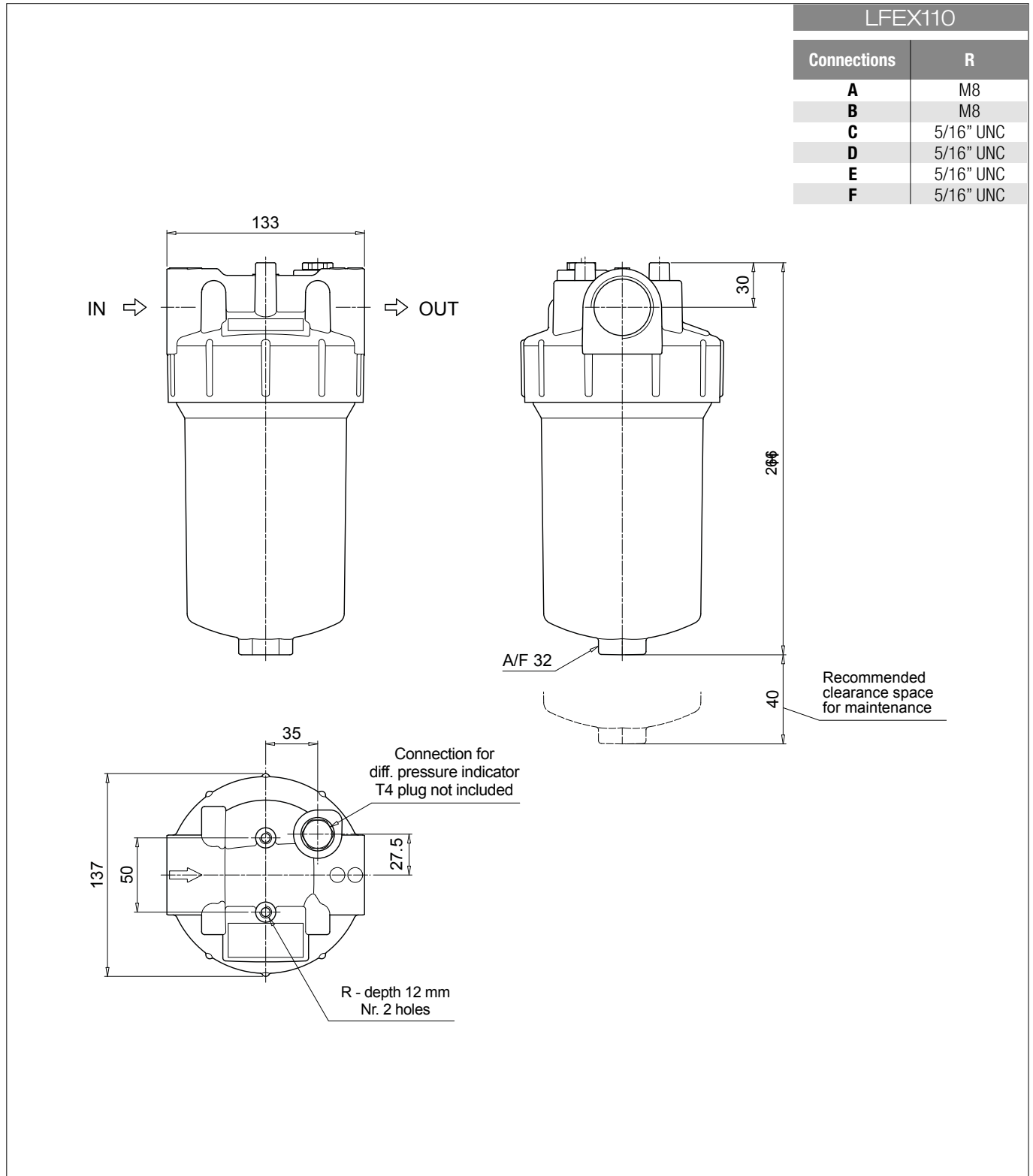

# LFEX110

## 6. Installation

- Check that the system working pressure does not exceed the maximum working pressure of the filter.  
The maximum working pressure of the filter is shown on the identification plate
- Check that the filter is compatible with the fluid used in the system
- Remove the plastic plugs from the inlet, the outlet and the indicator connection
- Check that the correct filter elements are fitted into the filter
- Check the flow direction (the flow is indicated by an arrow on the head)
- Install the clogging indicator, if required.  
In the case of using an electrical clogging indicator, follow the electrical diagram for correct installation
- Fasten the filter to the bracket with the correct bolts.  
Be sure to fit the filter without any tension stress
- Check that there is appropriate clearance for maintenance and the filter elements replacement.  
Correct operation is only guaranteed if the filter is installed in a vertical orientation with the filter housing at the top
- Check for a good view of the clogging indicator
- Connect the filter to the hydraulic system, using the appropriate hydraulic fittings.

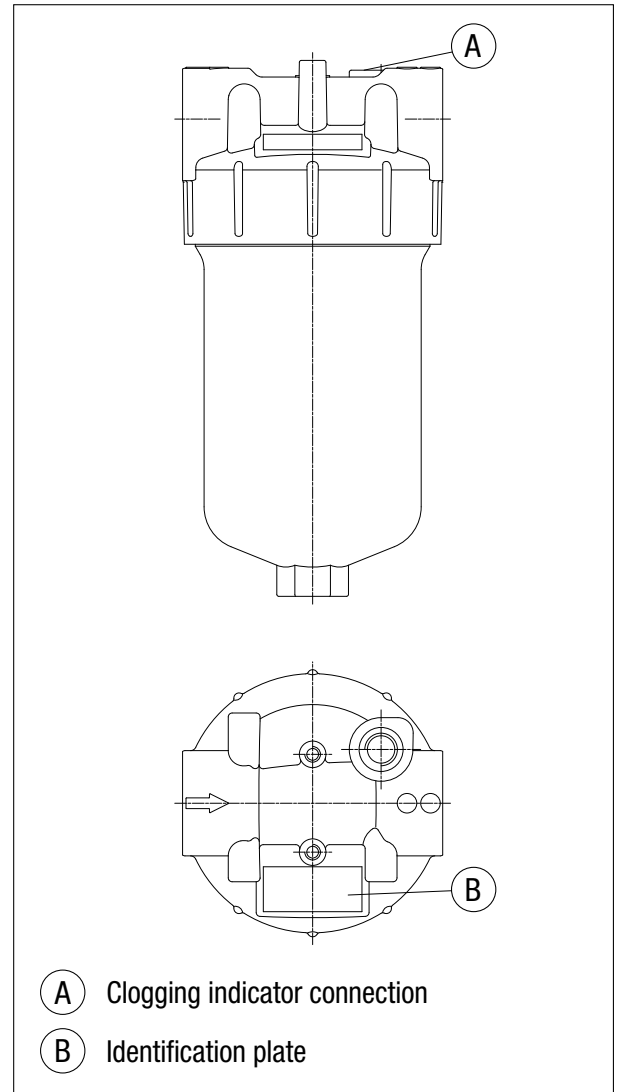

## 7. Commissioning

- Switch on the hydraulic system
- Check the filter is free of leaks
- Check the filter for leaks at the maximum working conditions (pressure, temperature ...)
- Check the filter does not cause excessive pressure drop checking that the indicator does not show the alarm signal.

## 8. Standard maintenance

### 8.1 FILTER ELEMENT REPLACEMENT

The clogging indicator monitors the conditions of the filter element. The alarm signal shown by the differential pressure indicator during the normal working conditions (pressure, temperatures ...) means that the filter element needs to be replaced.

- Check the availability of the right spare filter element by comparing the part number shown on the element with that shown on the filter name plate or spare parts list
- For the disassembly and the assembly of the parts, please refer to the tools table in paragraph 3
- Switch off the system
- (Fig. 1) Unscrew the filter bowl after placing a vessel to collect the operating fluid
- (Fig. 2) Empty the operating fluid from the bowl into the collection vessel
- (Fig. 3) Pull the filter element out after placing a protection from operating fluid dripping
- Clean the cavity in the housing, the tap and the bowl. Check them for damage.
- Check the condition of the bowl seals and, if necessary, replace them referring to the "Special maintenance" paragraph.
- (Fig. 4) Push the filter element into the bowl until the end cap hooks onto the internal teeth
- (Fig. 5) Lubricate with the operating fluid the filter housing tap, the filter element and bowl seals, and the threads of head cavity and bowl
- (Fig. 6) Fit the filter element on the tap and screw the bowl in referring to the tightening torque table in paragraph 3. Pay attention not to damage the seals
- Switch on the system and check the filter for leaks at the maximum working conditions (pressure, temperature...)
- For the disposal of replaced parts and the fluid removed from the container, refer to Chapter 15, paying particular attention to Section 15.2 - Waste Classification.

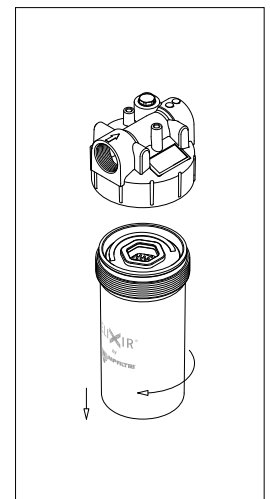

fig. 1

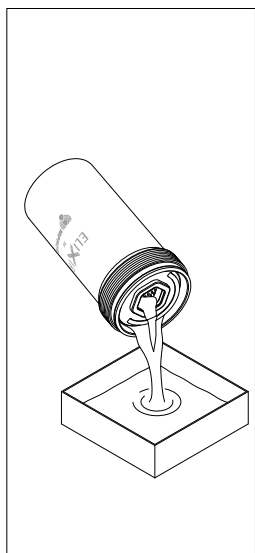

fig. 2

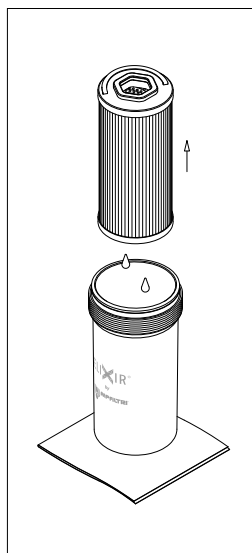

fig. 3

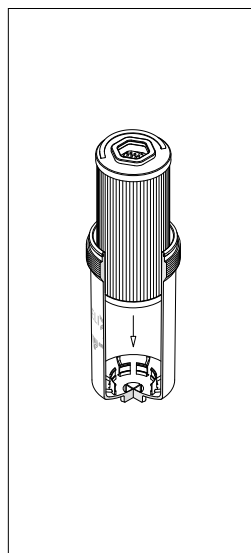

fig. 4

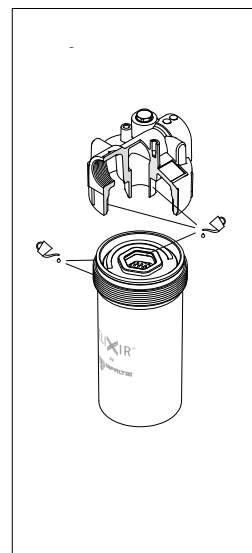

fig. 5

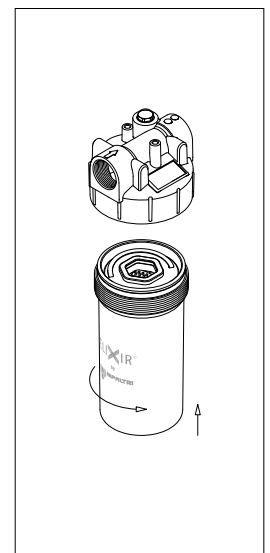

fig. 6

## 9. Special maintenance

### 9.1 CLOGGING INDICATOR (OR PLUG) REPLACEMENT

- Check the availability of the right spare parts by comparing the part numbers shown on them with that shown on the filter name plate or spare parts list
- For the disassembly and the assembly of the parts, please refer to the tools table in paragraph 3
- Switch off the system
- (Fig. 7) Unscrew the indicator body
- (Fig. 8) Lubricate with the operating fluid the thread and the O-ring of the indicator body, then screw the indicator body in referring to the tightening torque table in paragraph 3
- Switch on the system and check the filter for leaks at the maximum working conditions (pressure, temperature...)
- For the disposal of replaced parts and the fluid removed from the container, refer to Chapter 15, paying particular attention to Section 15.2 - Waste Classification.

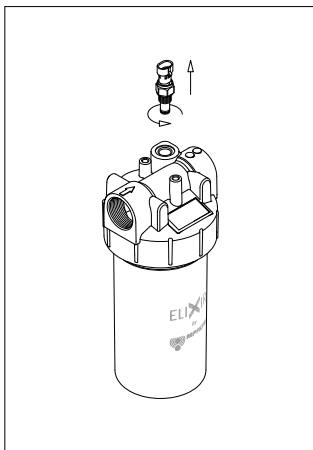

fig. 7

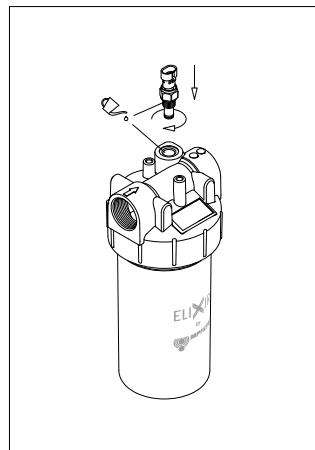

fig. 8

## 9.2 SEALS REPLACEMENT

- Check the availability of the right spare parts by comparing the part numbers shown on them with that shown on the filter name plate or spare parts list
- For the disassembly and the assembly of the parts, please refer to the tools table in paragraph 3
- Switch off the system
- (Fig. 9) Unscrew the filter bowl after placing a vessel to collect the operating fluid
- (Fig. 10) Empty the operating fluid from the bowl into the collection vessel
- (Fig. 11) Pull the filter element out after placing a protection from operating fluid dripping
- Remove all the seal from the bowl and the filter element and prepare the spare parts referring to the list in paragraph 12
- Clean the cavity in the housing, the tap and the bowl. Check them for damage
- (Fig. 12) Fit the O-ring in the bowl groove, insert the Hex-ring in the filter element cap
- (Fig. 13) Push the filter element into the bowl until the end cap hooks onto the internal teeth

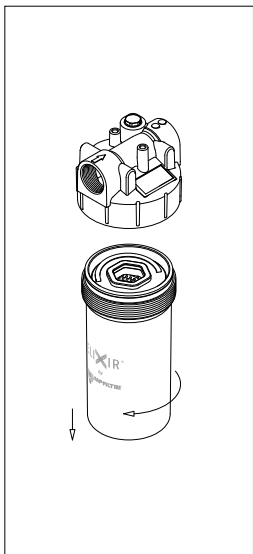

fig. 9

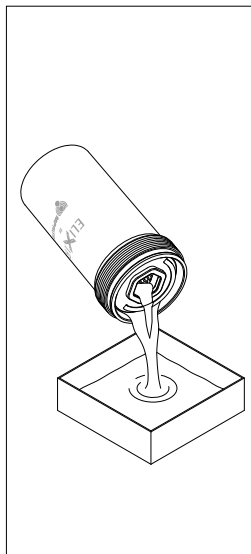

fig. 10

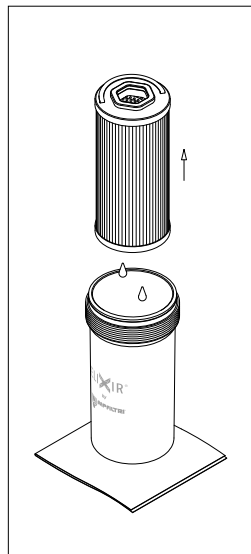

fig. 11

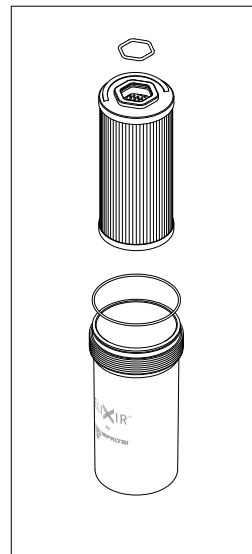

fig. 12

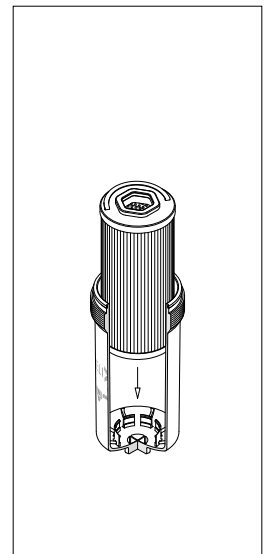

fig. 13

# LFEX110

- (Fig. 14) Lubricate with the operating fluid the filter housing tap, the filter element and bowl seals, and the threads of head cavity and bowl
- (Fig. 15) Fit the filter element on the tap and screw the bowl in referring to the tightening torque table in paragraph 3. Pay attention not to damage the seals
- (Fig. 16) Replace the O-rings of the indicator body
- For the mounting/dismounting of the indicator, please refer to the paragraph “Clogging indicator replacement” above (Fig. 7-8)
- Switch on the system and check the filter for leaks at the maximum working conditions (pressure, temperature...)
- For the disposal of replaced parts and the fluid removed from the container, refer to Chapter 15, paying particular attention to Section 15.2 - Waste Classification.

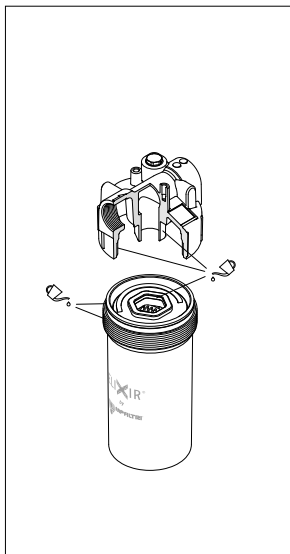

fig. 14

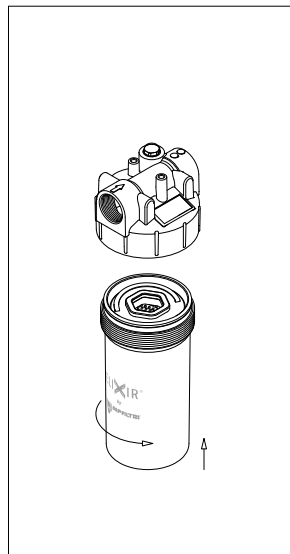

fig. 15

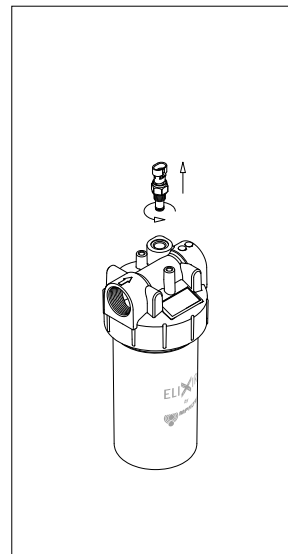

fig. 16

## 10. Instructions for use in explosive atmospheres

Hydraulic filters should be installed in applications in which special safety measures are required to prevent the triggering of explosive atmospheres, such as use in environments classified according to directive 1999/92/CE (ATEX) or the use of flammable fluids.

Conditions like the use of low conductivity fluids, which could cause electrostatic discharges, or installation near hot components, which could cause surfaces heating, could alter the safety of the filters.

MP FILTRI has carried out a voluntary certification of a part of the product range in compliance with directive 2014/34/EU, in order to guarantee an appropriate degree of safety in these particular conditions.

The content of the certification and the relative marking make them suitable for use in environments classified in accordance with directive 1999/92/CE (ATEX - ZONE 2).

## 11. Regulations

Hydraulic filters are not machines, but simple components.

Hydraulic filters are excluded from the scope of the Machinery Directive 2006/42/EC, they don't need the CE mark.

Hydraulic filters are designed to be fitted within a hydraulic system designed in accordance with the Machinery Directive 2006/42/EC.

Hydraulic filters are pressurized components. The maximum working pressure PS is over 0.5 bar, so they are subject to the Directive 2014/68/EU (PED)

LFEX filters are designed and manufactured for fluids included into the Group 2 defined by the Directive 2014/68/EU.

LFEX filters do not need the CE marking in accordance with the Directive 2014/68/UE Article 4, Section 3.

LFEX filters do not contain any substance of very high concern (SVHC) in percentage higher than 0.1% in accordance with the Regulation (EC) No 1907/2006 (REACH)

LFEX filters are designed and manufactured in accordance with the Commission Delegated Directive (EU) 2015/863 (RoHS).

# LFEX110

## 12. Spare parts list

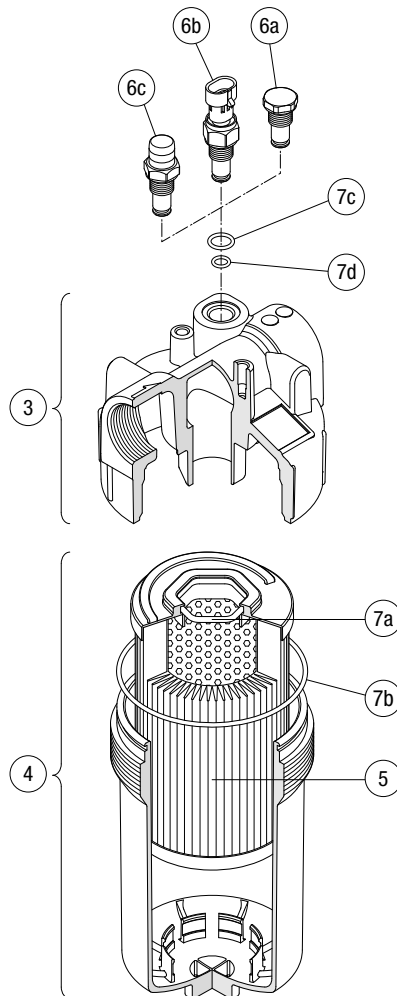

Item	Quantity	Description	Designation / Ordering code	
1	1	Complete filter	See "Ordering Code" table	
3	1	Housing		
4	1	Bowl assembly		
5	1	Filter element		
6	1	Clogging indicator		
7	1	Seals kit	NBR 02050772	FPM 02050774
7a	1	Filter element seal	Hex Ring - Private dimensions	
7b	1	Bowl seal	O-Ring 3425 - di = 107.62 - d <sub>2</sub> = 2.62	
7c	1	Filter element seal	O-Ring 1047 - di = 11.89 - d <sub>2</sub> = 1.98	
7d	1	Bowl seal	O-Ring 2031 - di = 7.66 - d <sub>2</sub> = 1.78	

## 13. Ordering code

### 13.1 FILTER / HOUSING

FILTER / HOUSING										
<b>Filter Series and size</b>		Filter:	LFEX110	B	A	A	6	A10	N	P01
<b>LFEX110</b>	Filter / housing featuring <b>MYCLEAN</b> filter element	Housing:	LFEX110	B	A	A	6			P01
<b>Bypass valve</b>										
<b>S</b>	Without bypass									
<b>B</b>	With bypass 3.5 bar									
<b>Seals</b>										
<b>A</b>	NBR									
<b>V</b>	FPM									
<b>Connections</b>										
<b>A</b>	G 1"									
<b>B</b>	G 1 1/4"									
<b>C</b>	1" NPT									
<b>D</b>	1 1/4" NPT									
<b>E</b>	SAE 16 - 1 5/16" - 12 UN									
<b>F</b>	SAE 20 - 1 5/8" - 12 UN									
<b>Connection for clogging indicator</b>										
<b>1</b>	Without									
<b>6</b>	With plugged connection									
<b>Filtration rating</b>										
<b>A03</b>	Inorganic microfiber	3 µm	<b>M25</b>	Wire mesh	25 µm					
<b>A06</b>	Inorganic microfiber	6 µm	<b>M60</b>	Wire mesh	60 µm					
<b>A10</b>	Inorganic microfiber	10 µm	<b>M90</b>	Wire mesh	90 µm					
<b>A16</b>	Inorganic microfiber	16 µm	<b>P10</b>	Resin impregnated paper	10 µm					
<b>A25</b>	Inorganic microfiber	25 µm	<b>P25</b>	Resin impregnated paper	25 µm					
<b>WA025</b>	Water absorber inorganic microfiber	25 µm								
		<b>Element Δp</b>			<b>Execution</b>					
		<b>N</b> 8 bar			<b>P01</b> MP Filtri standard					
					<b>Pxx</b> Customized					

### CLOGGING INDICATORS

**DES** Electrical differential pressure indicator

**DVS** Visual differential pressure indicator

**T4** Plug

# LFEX110

## 13.2 FILTER ELEMENT

FILTER ELEMENT	
<b>Element series and size</b> <b>FEX110</b> Filter Element with <b>MYCLEAN</b> feature	Configuration example: <b>FEX110</b> <b>A10</b> <b>A</b> <b>N</b> <b>P01</b>
<b>Filtration rating</b> <b>A03</b> Inorganic microfiber 3 µm <b>A06</b> Inorganic microfiber 6 µm <b>A10</b> Inorganic microfiber 10 µm <b>A16</b> Inorganic microfiber 16 µm <b>A25</b> Inorganic microfiber 25 µm <b>M25</b> Wire mesh 25 µm <b>M60</b> Wire mesh 60 µm <b>M90</b> Wire mesh 90 µm <b>P10</b> Resin impregnated paper 10 µm <b>P25</b> Resin impregnated paper 25 µm  <b>WA025</b> Water absorber inorganic microfiber 25 µm	
<b>Seals</b> <b>A</b> NBR <b>V</b> FPM	
<b>Element Δp</b> <b>N</b> 8 bar	
	<b>Execution</b> <b>P01</b> MP Filtri standard <b>Pxx</b> Customized

## 14. Troubleshooting

### 14.1 MISUSE OF THE PRODUCT

This product should be connected to a hydraulic line; this must not exceed upper pressure limit of the product. This product should follow all standard operating procedures previously set at the operating location as well as the procedures required by the manufacturer.

Over-tighten of test points/hoses can damage threads causing the unit to fail.  
The product is designed with no components in motion.

### 14.2 CLOGGING INDICATOR ALARM

In normal functioning of the system, the clogging of the filter by contaminants will result in a gradual increase in the pressure drop through the filter.

The filter element should be replaced before it is completely clogged and anyways before the pressure exceeds the setting value of the bypass valve. For this reason, we recommended using a clogging indicator (visual or electrical), that advises the appropriate timing for replacing the cartridge.

Should the clogging indicator be in alarm mode, it means that the pressure has already exceeded the guard threshold, and the cartridge has to be replaced.

### 14.3 LEAKS OF WORKING FLUID

Leaks from the connections with normal tightening may indicate seal damage during the warehousing process, fluid incompatibility, or unsuitable work conditions.

## 15. End-of-Life and Product Disposal

At the end of its service life, the hydraulic filter must be dismantled and disposed of properly, in compliance with applicable regulations regarding safety, environmental protection, and hazardous waste.

### 15.1 DISASSEMBLY

- **Depressurize the system** and remove the filter using appropriate personal protective equipment (PPE).
- Collect and dispose of **any residual oil** in accordance with local regulations.
- If the filter is of the **spin-on** type, dispose of it as hazardous waste due to the presence of residual oil and contaminated filter media.
- If the filter has a **replaceable cartridge**, separate the metal/plastic housing from the internal cartridge, where applicable.

### 15.2 WASTE CLASSIFICATION

The components of the used filter (cartridge, seals, metal/plastic parts) must be classified according to the **European Waste Catalogue (EWC)**. Generally:

- **15 02 02** - Absorbents and filter materials contaminated by hazardous substances
- **13 01 10 (\*)** - Mineral hydraulic oils containing PCBs or other hazardous substances
- **13 01 11 (\*)** - Other hydraulic oils

(\*) Always check with the local waste management authority for the correct assignment of codes and disposal procedures.

### 15.3 ENVIRONMENTAL RECOMMENDATIONS

- Do not dispose of filter components into the environment.
- Dispose of only through authorized operators, in compliance with current environmental regulations, in accordance (for European countries) with Directive 2008/98/EC, as well as applicable national legislations.
- Any metal components may be sent for recycling after appropriate treatment.



All data, details and words contained in this publication are provided for use by technically qualified personnel at their discretion, without warranty of any kind.

MP Filtri reserves the right to make modifications to the models and versions of the described products at any time for both technical and/or commercial reasons.

For updated information please visit our website: [www.mpfiltri.com](http://www.mpfiltri.com)

The colors and the pictures of the products are purely indicative.

Any reproduction, partial or total, of this document is strictly forbidden.

All rights are strictly reserved

# WORLDWIDE NETWORK

CANADA ♦ CHINA ♦ FRANCE ♦ GERMANY ♦ INDIA ♦ SINGAPORE  
UNITED ARAB EMIRATES ♦ UNITED KINGDOM ♦ USA



PASSION  PERFORM

in @ y f



[mpfiltri.com](http://mpfiltri.com)  
Scan or click me!