

HFEX series

Maximum working pressure up to 3.5 MPa (35 bar) Flow rate up to 300 l/min



Description

Technical data

Low & Medium Pressure filters

Maximum working pressure up to 3.5 MPa (35 bar)
Flow rate up to 300 l/min

HFEX is a range of low pressure filter for protection of sensitive components in low pressure hydraulic systems. They are also suitable for the off-line filtration of small reservoirs.

They are directly connected to the lines of the system through the hydraulic fittings.

Available features:

- Female threaded connections up to 1 1/4", for a maximum flow rate of 300 l/min
- Fine filtration rating, to get a good cleanliness level into the system
- Water removal elements, to remove the free water from the hydraulic fluid
- Bypass valve, to relieve excessive pressure drop across the filter media
- Visual and electrical differential clogging indicators, capable to hold the overall dimension
- MYclean interface connection for the filter element, to protect the product against non-original spare parts
- External protective wrap, to optimize the flow through the element and to save the element efficiency against non-proper handling.

Common applications:

Delivery lines, in any low pressure industrial equipment or mobile machines.

Filter housing materials

- Head: Aluminium
- Bypass valve: Polyamide - Steel
- Bowl: Aluminium

Bypass valve

Opening pressure 350 kPa (3.5 bar) ±10%

Filter element features

Filter HFEX		Filter element FEX	
Δp Element type			
Element media	Construction	Δp Series	Δp
A - Microfiber	Standard	N	8 bar
M - Wire mesh	Standard	N	8 bar
P - Paper	Standard	N	8 bar
<i>Please see ordering code tables to check element Δp series availability based on filter features.</i>			
Flow direction through the filter element:			
From OUT to IN			

Seals

Standard NBR series A

Temperature

From -25 °C to +110 °C

Note

HFEX filters are provided for vertical mounting

Weights [kg] and volumes [dm³]

Filter series	Weights [kg]	Volumes [dm ³]
HFEX 060	1.50	0.60
HFEX 080	1.85	0.80
HFEX 110	2.60	1.60
HFEX 160	2.95	2.00

Filter element design - N Series

Filter series	A03	A06	A10	A16	A25	M25	M60	M90	P10	P25
HFEX 060	45	47	65	66	68	84	84	86	67	73
HFEX 080	58	59	73	72	76	86	87	88	79	82

Connections of filter under test G 3/4"

Filter series	A03	A06	A10	A16	A25	M25	M60	M90	P10	P25
HFEX 060	49	51	75	77	80	104	105	107	74	95
HFEX 080	67	67	86	87	92	107	108	110	96	112

Connections of filter under test G 1"

Filter series	A03	A06	A10	A16	A25	M25	M60	M90	P10	P25
HFEX 110	107	115	182	195	216	295	298	300	232	242
HFEX 160	146	150	210	212	237	300	303	304	254	262

Connections of filter under test G 1 1/4"

Maximum flow rate for a complete delivery filter with a pressure drop $\Delta p = 0.7$ bar.

The reference fluid has a kinematic viscosity of 30 mm²/s (cSt) and a density of 0.86 kg/dm³.

For different pressure drop or fluid viscosity we recommend to use our selection software available on www.mpfiltri.com.

Please, contact our Sales Department for further additional information.

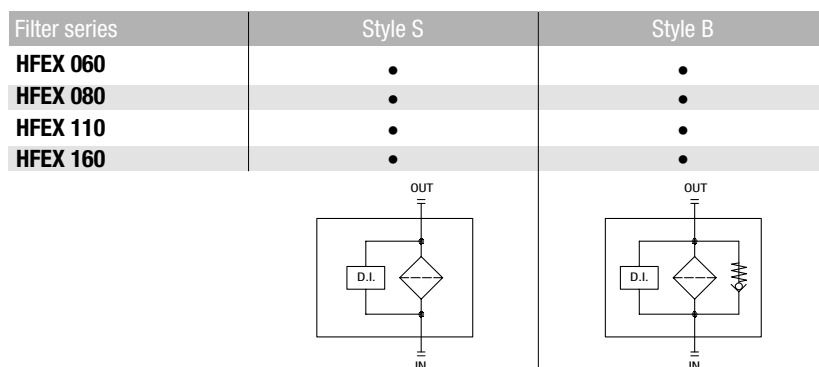

Hydraulic diagram

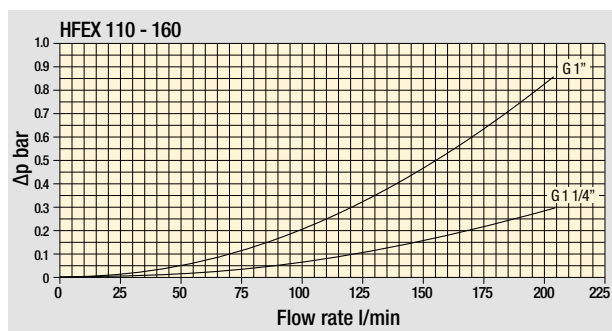
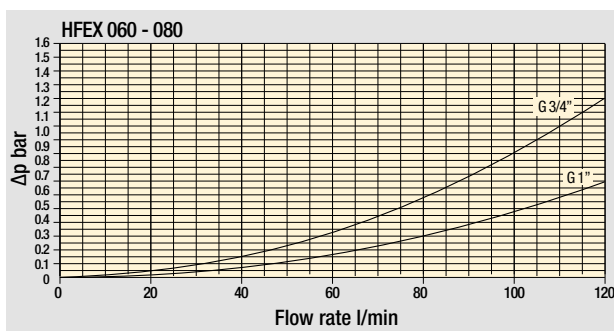

Pressure drop
Filter housings
 Δp pressure drop

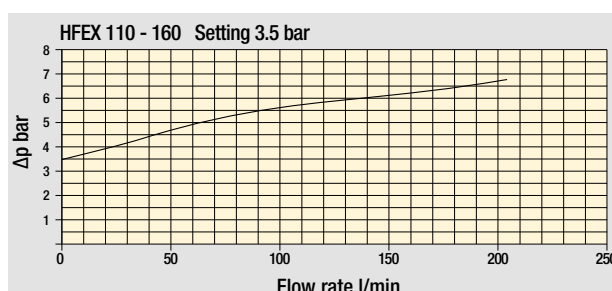
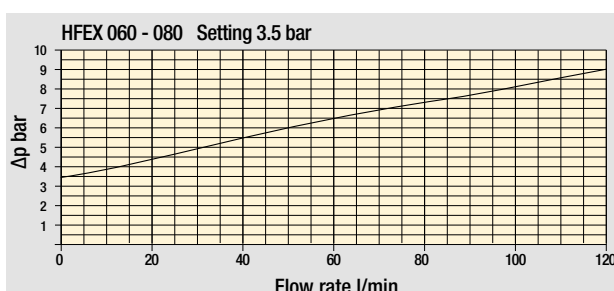

Bypass valve
pressure drop

The curves are plotted using mineral oil with density of 0.86 kg/dm³ in compliance with ISO 3968.

Δp varies proportionally with density.

HFEX HFEX060 - HFEX080

Designation & Ordering code

COMPLETE FILTER

Configuration example: **HFEX060** **B** **A** **A** **6** **A10** **N** **P01**

Series and size
HFEX060
HFEX080

Bypass valve
S Without bypass
B 3.5 bar

Seals and treatments
A NBR

Connections
A G 3/4"
B G 1"
C 3/4" NPT
D 1" NPT
E SAE 12 - 1 1/16" - 12 UN
F SAE 16 - 1 5/16" - 12 UN

Connection for clogging indicator
1 Without
6 With plugged connections

Filtration rating

A03 Inorganic microfiber	3 µm	M25 Wire mesh	25 µm
A06 Inorganic microfiber	6 µm	M60 Wire mesh	60 µm
A10 Inorganic microfiber	10 µm	M90 Wire mesh	90 µm
A16 Inorganic microfiber	16 µm	P10 Resin impregnated paper	10 µm
A25 Inorganic microfiber	25 µm	P25 Resin impregnated paper	25 µm

WA025 Water absorber inorganic microfiber 25 µm

Element Δp
N 8 bar

Execution
P01 MP Filtri standard
Pxx Customized

FILTER ELEMENT

Configuration example: **FEX060** **A10** **A** **N** **P01**

Element series and size
FEX060
FEX080

Filtration rating

A03 Inorganic microfiber	3 µm	M25 Wire mesh	25 µm
A06 Inorganic microfiber	6 µm	M60 Wire mesh	60 µm
A10 Inorganic microfiber	10 µm	M90 Wire mesh	90 µm
A16 Inorganic microfiber	16 µm	P10 Resin impregnated paper	10 µm
A25 Inorganic microfiber	25 µm	P25 Resin impregnated paper	25 µm

WA025 Water absorber inorganic microfiber 25 µm

Seals and treatments
A NBR

Element Δp
N 8 bar

Execution
P01 MP Filtri standard
Pxx Customized

CLOGGING INDICATORS

See page 784

- DES** Electrical differential pressure indicator
- DVS** Visual differential pressure indicator

Filter size	H [mm]
060	210
080	273

Connections	R
A	M6
B	M6
C	1/4" UNC
D	1/4" UNC
E	1/4" UNC
F	1/4" UNC

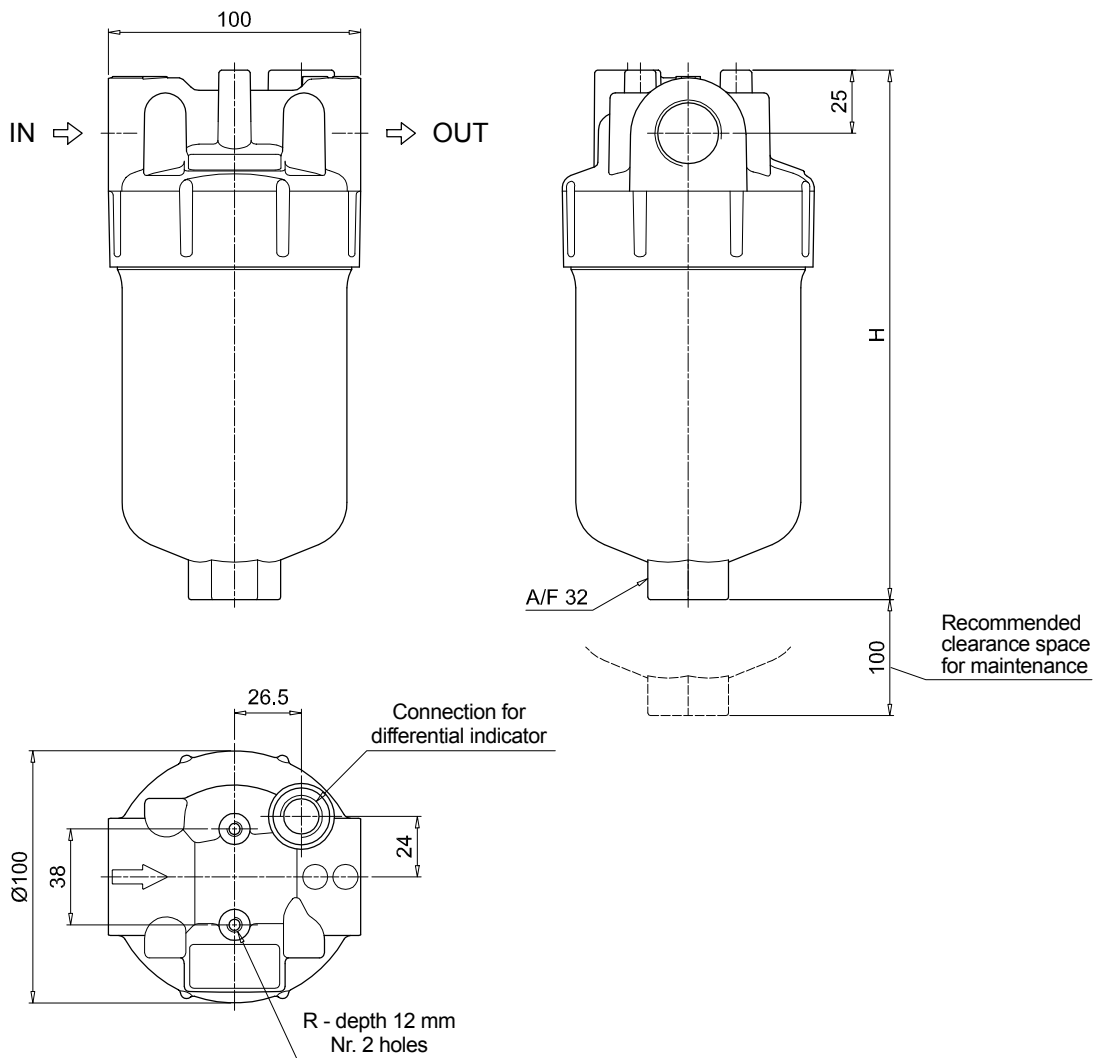

HFEX HFEX110 - HFEX160

Designation & Ordering code

COMPLETE FILTER

Configuration example: **HFEX110** **B** **A** **A** **6** **A10** **N** **P01**

Series and size
HFEX110
HFEX160

Bypass valve
S Without bypass
B 3.5 bar

Seals and treatments
A NBR

Connections
A G 1"
B G 1 1/4"
C 1" NPT
D 1 1/4" NPT
E SAE 16 - 1 5/16" - 12 UN
F SAE 20 - 1 5/8" - 12 UN

Connection for clogging indicator
1 Without
6 With plugged connections

Filtration rating

A03 Inorganic microfiber	3 µm	M25 Wire mesh	25 µm
A06 Inorganic microfiber	6 µm	M60 Wire mesh	60 µm
A10 Inorganic microfiber	10 µm	M90 Wire mesh	90 µm
A16 Inorganic microfiber	16 µm	P10 Resin impregnated paper	10 µm
A25 Inorganic microfiber	25 µm	P25 Resin impregnated paper	25 µm

WA025 Water absorber inorganic microfiber 25 µm

Element Δp
N 8 bar

Execution
P01 MP Filtri standard
Pxx Customized

FILTER ELEMENT

Configuration example: **FEX110** **A10** **A** **N** **P01**

Element series and size
FEX110
FEX160

Filtration rating

A03 Inorganic microfiber	3 µm	M25 Wire mesh	25 µm
A06 Inorganic microfiber	6 µm	M60 Wire mesh	60 µm
A10 Inorganic microfiber	10 µm	M90 Wire mesh	90 µm
A16 Inorganic microfiber	16 µm	P10 Resin impregnated paper	10 µm
A25 Inorganic microfiber	25 µm	P25 Resin impregnated paper	25 µm

WA025 Water absorber inorganic microfiber 25 µm

Seals and treatments
A NBR

Element Δp
N 8 bar

Execution
P01 MP Filtri standard
Pxx Customized

CLOGGING INDICATORS

See page 784

- DES** Electrical differential pressure indicator
- DVS** Visual differential pressure indicator

HFEX SPARE PARTS

Order number for spare parts

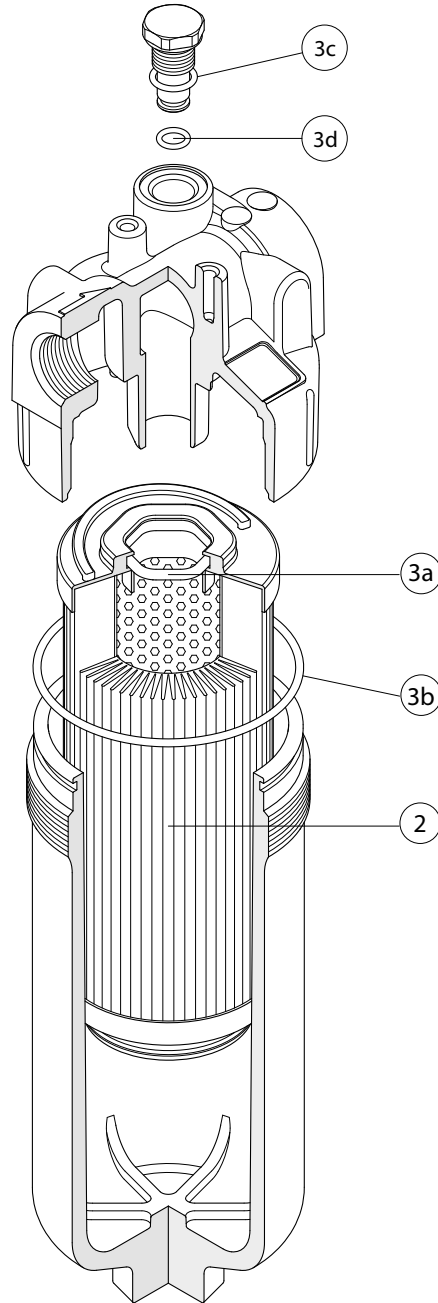

Item:	Q.ty: 1 pc.	Q.ty: 1 pc.	Q.ty: 1 pc.
	2	3 (3a ÷ 3d)	4
Filter series	Filter element	Seal Kit code number NBR	Indicator connection plug NBR
HFEX 060-080	See order table	02050771	T3H
HFEX 110-160		02050772	