

MOBILE FILTRATION UNIT

INSTALLATION,
SERVICE AND
MAINTENANCE
MANUAL
AND SAFETY
INSTRUCTIONS

UFM091



EN

PASSION  PERFORM



PRODUCT OVERVIEW

UFM091 filtration unit series

Key features:

- Transfer
- Filtration
- Flow rates 90 l/min
- Maximum working pressure 10 bar
- Absolute filtration
- Wide range of filtration media
- Water removal filter elements
- Single-phase and three-phase motors
- Comprehensive choice of configurations
- In-line contamination monitoring (ICM2.0 series particle counter)
- Equipped with handles and wheels for easy portability
- CE standard





DECLARATION OF CONFORMITY

CE EC declaration DECLARATION OF CONFORMITY IN ACCORDANCE WITH 2006/42/EC MACHINERY DIRECTIVE

The company:

MP Filtri S.p.A.
Via 1° Maggio, 3
20042 - Pessano con Bornago (MI) - Italy

as a manufacturer, it declares that the machine:

Name	Code / Model
MOBILE FILTRATION UNIT	UFM091TA2020P01 UFM091TA3020P01 UFM091TA3021P01

to which this declaration refers, complies with the following Directives: **2006/42/EC Machinery Directive.**

Furthermore, the technical documentation was compiled in accordance with **Annex VII Part A.**

The machine also complies with the provisions of the following standards:

- UNI EN ISO 12100-1-2:2010 Safety of machinery
- UNI EN ISO 13857:2008 Safety of machinery - Safety distances to prevent the reaching into dangerous areas with the upper and lower limbs
- UNI EN ISO 13732-1:2009 Ergonomics of thermal environments - Methods for evaluating human response to contact with surfaces
- UNI EN ISO 4413:2012 Hydraulics - General rules and safety requirements for systems and their components

Pessano con Bornago, 14/05/2019

Chief Executive Officer
CEO



	Page
PRODUCT OVERVIEW	1
Declaration of Conformity	3
Table of contents	4
GENERAL WARNINGS	
1 General warnings and information for the recipient	6
1.1 General information	6
1.2 General and safety instructions	6
1.3 Operator station and dangerous areas	8
1.4 Hazards and risks that cannot be eliminated	8
1.5 Personal protective equipment	8
TRANSPORT AND STORAGE	
2 Transport and handling conditions	9
GENERAL WARRANTY CONDITIONS	
3 Warranty, limits and exclusions	11
PRODUCT DOCUMENTATION	
4 Mobile transfer and filtration units	12
4.1 Test certificate	13
4.2 Download Area	13

TABLE OF CONTENTS

UFM 091 - MOBILE FILTRATION UNIT

	Page
5 Technical features	15
5.1 Dimensions	16
5.2 Hydraulics diagrams and material list	17
6 Installation procedures and general operation	20
6.1 Introduction	20
6.2 Filter element installation	20
6.3 Wiring diagram	21
6.3.1 Electrical connection	21
6.3.2 Triangular electrical connection of a three-phase motor	21
6.3.3 Electrical connection of a single-phase motor	-
6.3.4 Electrical panel	22
6.3.5 Electrical panel labels	22
6.4 Use	23
6.4.1 Installation	23
6.4.2 Power on	23
6.4.3 Air vent	25
6.4.4 Oil analysis with particle counter	25
6.4.5 Shutdown	26
6.4.6 Operating limits and environmental limits	27
6.5 Normal and scheduled maintenance	27
6.5.1 Oil leaks	27
6.6 Filter clogging	28
6.6.1 Replacing filter element	28
6.6.2 Air vent	30
6.6.3 Replacing and cleaning of the filter in the suction line	30
7 Designation & ordering code	31
8 Spare parts	32
8.1 List of spare parts	32
8.2 Filter element detail	34

1 General warnings and information for the recipient

1.1 General information

The mobile filtration units of the UFM series have been designed and manufactured in compliance with the machinery directive and the low voltage directive with regards to electric motors. The EC Declaration of Conformity is included in this manual. The warranty has a duration of twelve months starting from the date shown on the delivery note. To consult “General Warranty Conditions” section of this Use and Maintenance Manual.

1.2 General and safety instructions

Read this manual carefully before commissioning, maintenance or other activities on or with the unit. Each operator involved in the operation of the mobile filtration unit must wear the following personal protective equipment:



Safety glasses



Safety shoes



Gloves

Before carrying out any installation or work on and/or with the machine it is necessary to strictly follow the instructions listed in this manual. It is also necessary to comply with the provisions in force concerning accident prevention and safety in the workplace. The warnings to prevent dangers to the health of the personnel assigned to the machine, are highlighted in this documentation with signal words to notifications:

If important information concerning the product affects the use of the product or a part of this documentation, all of it must be particularly taken into account.



NOTE

This means that failure to comply with the relevant safety regulations may result in slight injury or damage to equipment.



CAUTION

This means that failure to comply with the relevant safety regulations can result in death, serious injury or considerable damage to equipment.



DANGER

GENERAL WARNINGS

To allow rapid identification of the employees who must read this manual, definitions have been used with the following meaning:

OPERATOR	The person in charge of using the machine for productive purposes. The operator is aware of the measures taken by the machine manufacturer to eliminate the sources of risk of accidents at work and complies with the operational constraints.
PERSONNEL INVOLVED IN SLINGING AND HOISTING OPERATIONS	The person in charge of handling the machine or parts thereof. The slinger is aware of the problems concerning the transport of machines or parts thereof in safe conditions; for this purpose, they use lifting equipment suitable for the purpose following the instructions provided by the machine manufacturer.
MACHINE SETTER	The person in charge of preparing the machine for normal operation. The machine setter is aware of the measures taken by the machine manufacturer to eliminate the sources of risk of accidents at work and complies with the operational constraints. The machine setter takes the necessary precautions to intervene in conditions of maximum safety.
MAINTENANCE TECHNICIAN	The person in charge of performing maintenance operations on the machine. The maintenance technician is aware of the possible dangerous situations that may arise during his work and takes the necessary precautions to avoid risks of accidents at work.
ELECTRICIAN	The person in charge of carrying out maintenance operations on the machine's electrical system. The electrician is aware of the possible dangerous situations that may arise during his work and takes appropriate precautions to avoid risks of accidents at work.

1.3 Operator station and dangerous areas

Areas adjacent to the electric motor due to the presence of live equipment and potentially very hot surfaces are to be considered as dangerous areas. The operator has no reason to access electrical equipment and is not authorised to do so.

The trolley must be taken out of service and/or dismantled in full compliance with the regulations in force at that time in the country where the machine is installed.



NOTE

The machine is not suitable for outdoor use and all electrical equipment has a minimum degree of protection IP 55.



NOTE

1.4 Hazards and risks that cannot be eliminated

Risk of electric shock on the electric motor, in case of motor malfunction, risk of burns due to high temperature, accidental oil leakage with consequent possibility of slipping, rupture of the hoses with consequent loss of lubricant.

With oil temperatures above 40/45 °C, take extra caution in the handling of metal lances/tubes and movement of the mobile filtration unit. Avoid direct contact with hot oil and the filter housing.

1.5 Personal Protective Equipment

For normal use of the mobile filtration unit, safety shoes, gloves and safety glasses must be worn. In general the PPE to be used according to the operations on the machine are summarised in the following table:

OPERATION	PPE
Normal operation	Safety shoes, protective gloves, safety glasses
Normal maintenance	Safety shoes, protective gloves, safety glasses



TRANSPORT / STORAGE

2 Transport and handling conditions

The filtration unit is transported packaged with strapping and plastic film.
The product is moved by means of wheels. The movement of the same is carried out by acting on the special handle.
The weight of each individual unit is shown below:

Total weight UFM091	105 kg
---------------------	--------



GENERAL WARRANTY CONDITIONS

3 Warranty, limits and exclusions

- 1 - The seller assumes a guarantee of the normal mechanical operation of their product for a period of one year (except as provided for in Item H4 referred to the general conditions of sale and warranty sent with each order confirmation) from the delivery date.
- 2 - The warranty is limited to the replacement of damaged or defective parts due to poor quality of the material or construction. It does not extend to defects due to normal wear or due to inexperience or negligence of the customer and to parts that due to the composition of the material or the nature of their use are subject to rapid wear.
- 3 - Damage or defects must be declared, under penalty of forfeiture, by registered letter within eight days of discovery. The seller, once being aware of the existence of the defect, is obligated to replace the defective elements if they have not been tampered with due to attempted repair or modification by the customer (or third parties), and provided that he has punctually fulfilled the contractual obligations, with particular regard to payments which, if not carried out in the manner and within the agreed terms, entail the forfeiture of the guarantee and the seller's right not to effect the replacements.
- 4 - Any other indemnity, request for compensation for damages, also by third parties, due to production shutdown of the customer is expressly excluded.
- 5 - The items to be replaced must be sent with transport costs to be paid by the purchaser ex works of the seller who will replace them as soon as possible with delivery to their premises. The replaced parts belonging to the customer remain at his disposal for eight days within which they can be collected; following this deadline the seller is entitled to regard them as scrap in his possession without any compensation.
- 6 - The examination of the failures and their causes will always be carried out in the seller's workshops and all the related costs will be borne by the customer. The customer is also responsible for all inspection costs that may be requested on site. In no case may the customer demand the termination of the contract.
- 7 - The warranty is not transferable and applies only to the invoice recipient.
- 8 - The warranty is no longer valid when one of the following conditions is the case:
 - a) payments are not made by the client in the manner and terms agreed
 - b) tampering with what is provided without the seller's explicit authorisation
 - c) improper use of what is supplied
 - d) failure to perform maintenance
 - e) installation, modification, replacement of parts or of what is supplied

4 Mobile transfer and filtration units

The UFM series mobile filtration units are machines designed for transferring and filtering lubricants and hydraulic oils. The UFM015 version can be moved thanks to the use of handle and low weight, all other versions have wheels for moving. They can be used with fluids at different temperatures (therefore different viscosities) as long as they fall within the limits indicated by this manual. Operation with Mineral Oils, Synthetic Fluids & HFCs.

NOTE

The machine can be used for:

TRANSFER

- transferring from drums into tanks
- to refill from drums into tanks

FILTRATION

- off-line filtration in tanks
- additional off-line filtration system in tanks
- off-line filtration of new oil into drums or underground/large tanks
- Particle counting and determination of cleanliness class according to ISO4406, NAS1638, AS4059 (only for versions with ICM mounted on UFM051-091-181-919)
- Measurement of the water saturation level (RH) contained in the fluid and of the temperature

Depending on the version, the mobile filtration units can use filter elements and cartridges with different filtering media, filtration degree and dimensions; the fibre filter elements have high storage capacity and absolute filtration $B_{x(c)} > 1000$.

Single-phase and three-phase electric motors.

Wide range of flow rate, from 15 l/min to 180 l/min.

Optical and electrical systems for filter monitoring.

Electrical systems for greater safety:

- unit shutdown in case of clogged filter (from the UFM041 version onwards)
- unit shutdown when the set cleanliness class is reached (particle counter version only).

Before commissioning the equipment make sure:

- you have read this manual carefully
- check the good condition of the mobile filtration unit
- report any damage or breakages suffered by the mobile filtration unit during transport
- verify the presence of all the accessories supplied

PRODUCT DOCUMENTATION

4.1 Test certificate

Hard copy of test certificate is attached to the cart.

4.2 Download Area

Please scan the QR codes below to get updated electronic version of the related document.

MOBILE FILTRATION UNIT
General catalogue







 Download PDF

CONTAMINATION MONITORING PRODUCTS General catalogue





 Download PDF

QUICK GUIDE
UFM series

 Download multi-language PDF

USER'S MANUAL - UFM series

    Select your language and download PDF

<p>UFM 015</p> 	<p>UFM 041</p> 	<p>UFM 045</p> 	<p>UFM 051</p> 
<p>UFM 091</p> 	<p>UFM 181</p> 	<p>UFM 919</p> 	

CMP View Software
Software multilingual

Download Software





CMP View Software
Quick Guide

 Select your language and download PDF

ICM
User's Guide

 Select your language and download PDF



UFM091

5 Technical features

The mobile filtration unit consists of a support frame with handle and wheels for manoeuvrability. The assembly/motor pump connected to the hoses is used for suctioning and discharging the fluid. It is equipped with a suction filter and a discharge filter. The mobile filtration unit is complete with electrical and mechanical safety systems, for the filter and the assembly/motor pump.

Pump	Screw pump with integrated pressure relief valve
Electric motor	2.2 kW 400/230 V three-phase
Flow rate (l/min)	90 l/min - 1450 rpm
Max. working pressure	10 bar
Viscosity	Minimum operating viscosity 10 cSt Maximum operating viscosity 800 cSt Maximum only for cold starts 2000 cSt
Suction filter	Y-shape fine filter unit 800 µm
Type of filtering mat/degree of filtration	Fibre 1/3/6/10/16/25 $\beta_{x(c)} > 1000$
Internal/external filtration	Wire mesh 25/60 µm Water absorber
Bypass valve Δp set	3.5 bar
Fluid temperature	from -10 °C to +80 °C
Ambient temperature	from -20 °C to +45 °C
Protection class	IP 55
Seals	NBR
Compatibility with hydraulic fluids	Mineral & Synthetic oils. For other fluids contact MP Filtri.
Hoses	Flexible suction hose DN50 L = 3000 mm Nozzle $\varnothing_e = 50$ L = 700 mm Flexible delivery hose DN38 L = 3000 mm Nozzle $\varnothing_e = 42$ L = 700 mm
Weight	105 kg
Standard equipment	Main filter bypass valve blocking Pressure gauge
Equipment according to the versions	
UFM091TA2020P01	Visual clogging indicator
UFM091TA3020P01	Electric clogging indicator with automatic motor stop
UFM091TA3021P01	Electric clogging indicator with automatic motor stop, ICM2.0 series particle counter and communication module

NOTE 1/NOTE 2

Microfibre filter elements with water absorber: disposable components

NOTE 1

The system is supplied without filter element

NOTE 2

5.1 Dimensions

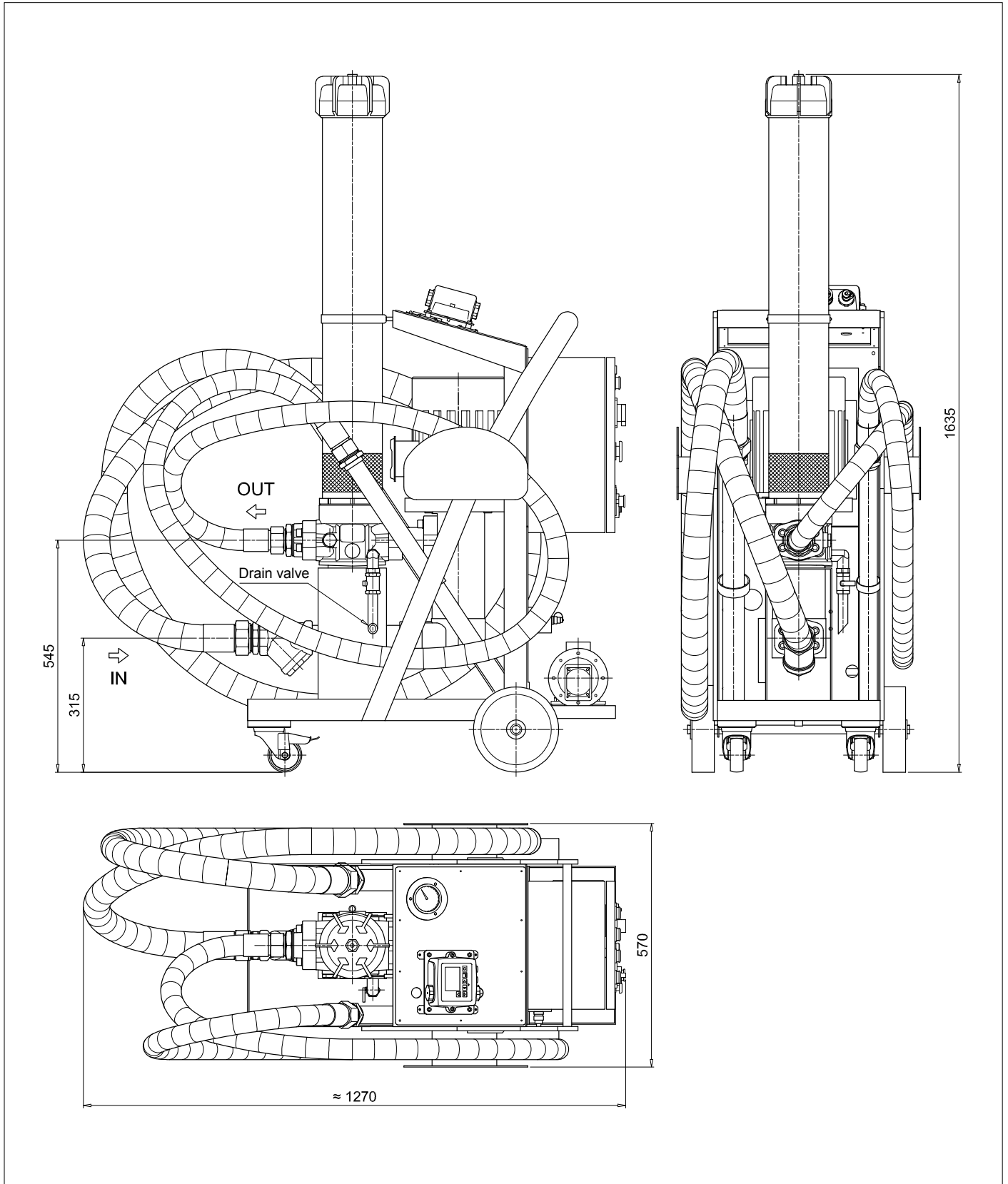

UFM091

5.2 Hydraulic circuit and bill of materials

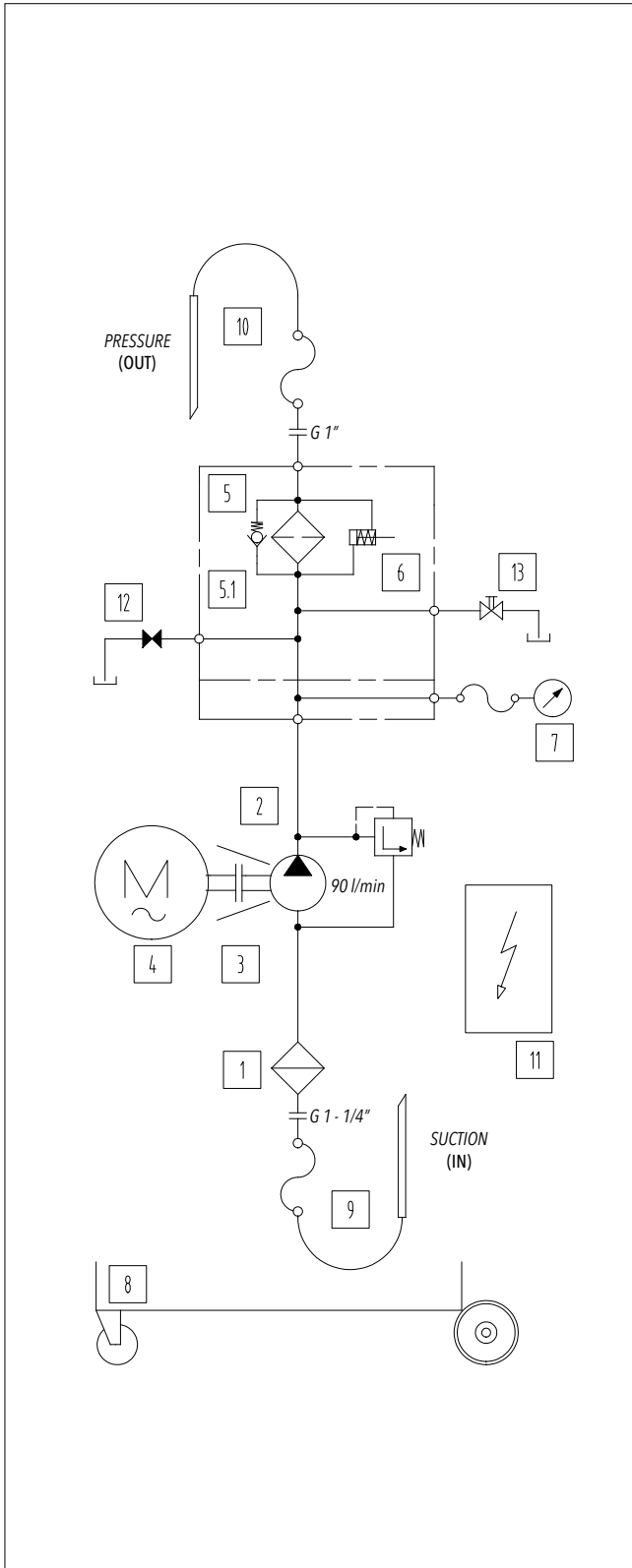

Version:
UFM091TA2020P01

Position	Quantity	Description
1	1	Y shaped filter 800 µm
2	1	Gear pump / screw
3	1	Motor/pump coupling
4	1	Three-phase electric motor 2.2 kW 4P-B3/B5 (IE3)
5	1	Increased filter length
5.1	1	Microfibre filter element 1 µm Microfibre filter element 3 µm Microfibre filter element 6 µm Microfibre filter element 10 µm Microfibre filter element 16 µm Microfibre filter element 25 µm Filter element in wire mesh 25 µm Filter element in wire mesh 60 µm Water absorber filter element
6	1	Visual differential pressure indicator
7	1	Pressure gauge
8	1	Mobile unit frame
9	1	DN50 flexible suction hose + nozzle
10	1	DN38 flexible discharge hose + nozzle
11	1	Electrical panel three-phase version
12	1	Drain valve
13	1	Air vent valve

NOTE

>> NEXT

Microfibre filter elements with water absorber: disposable components

NOTE

>> NEXT

Hydraulic circuit and bill of materials

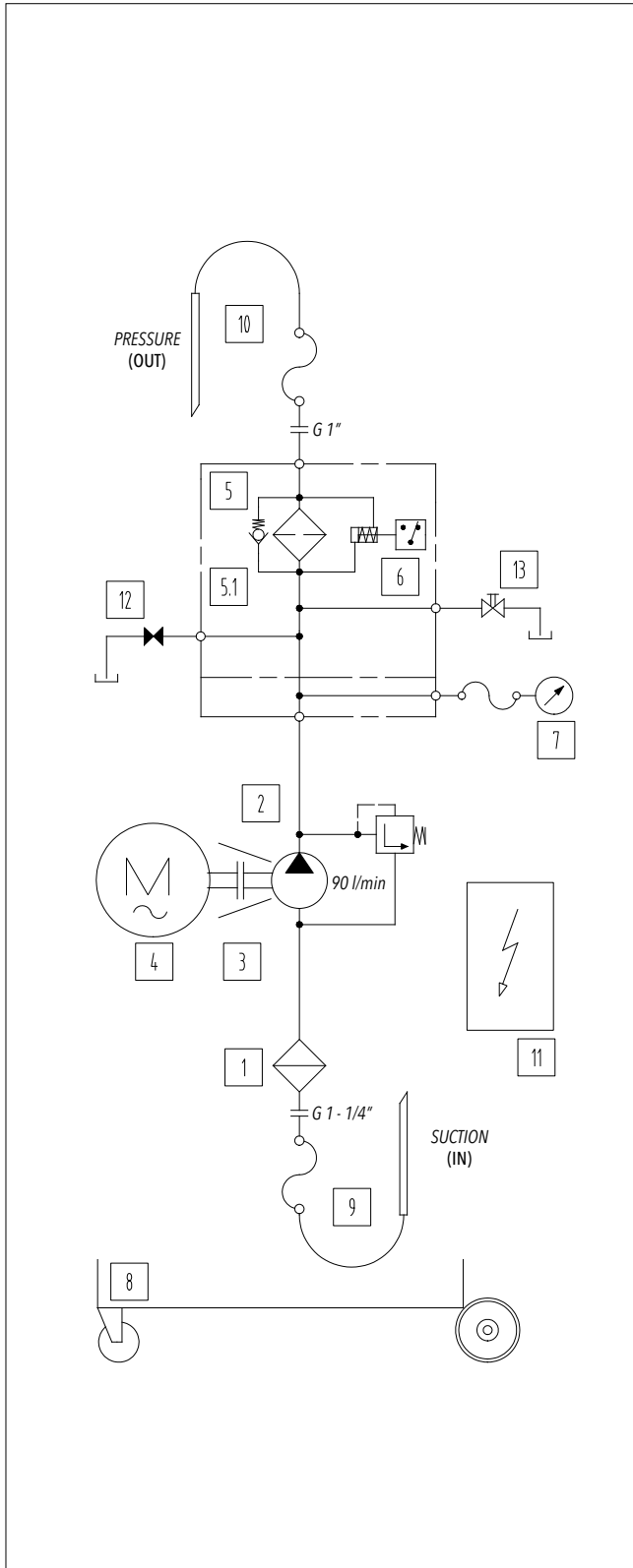

Version:
UFM091TA3020P01

Position	Quantity	Description
1	1	Y shaped filter 800 µm
2	1	Gear pump / screw
3	1	Motor/pump coupling
4	1	Three-phase electric motor 2.2 kW 4P-B3/B5 (IE3)
5	1	Increased filter length
5.1	1	Microfibre filter element 1 µm Microfibre filter element 3 µm Microfibre filter element 6 µm Microfibre filter element 10 µm Microfibre filter element 16 µm Microfibre filter element 25 µm Filter element in wire mesh 25 µm Filter element in wire mesh 60 µm Water absorber filter element
6	1	Electric diff. pressure indicator (visual indication on panel)
7	1	Pressure gauge
8	1	Mobile unit frame
9	1	DN50 flexible suction hose + nozzle
10	1	DN38 flexible discharge hose + nozzle
11	1	Electrical panel three-phase version
12	1	Drain valve
13	1	Air vent valve

NOTE

>> NEXT

Microfibre filter elements with water absorber: disposable components

NOTE

UFM091

>> NEXT

Hydraulic circuit and bill of materials

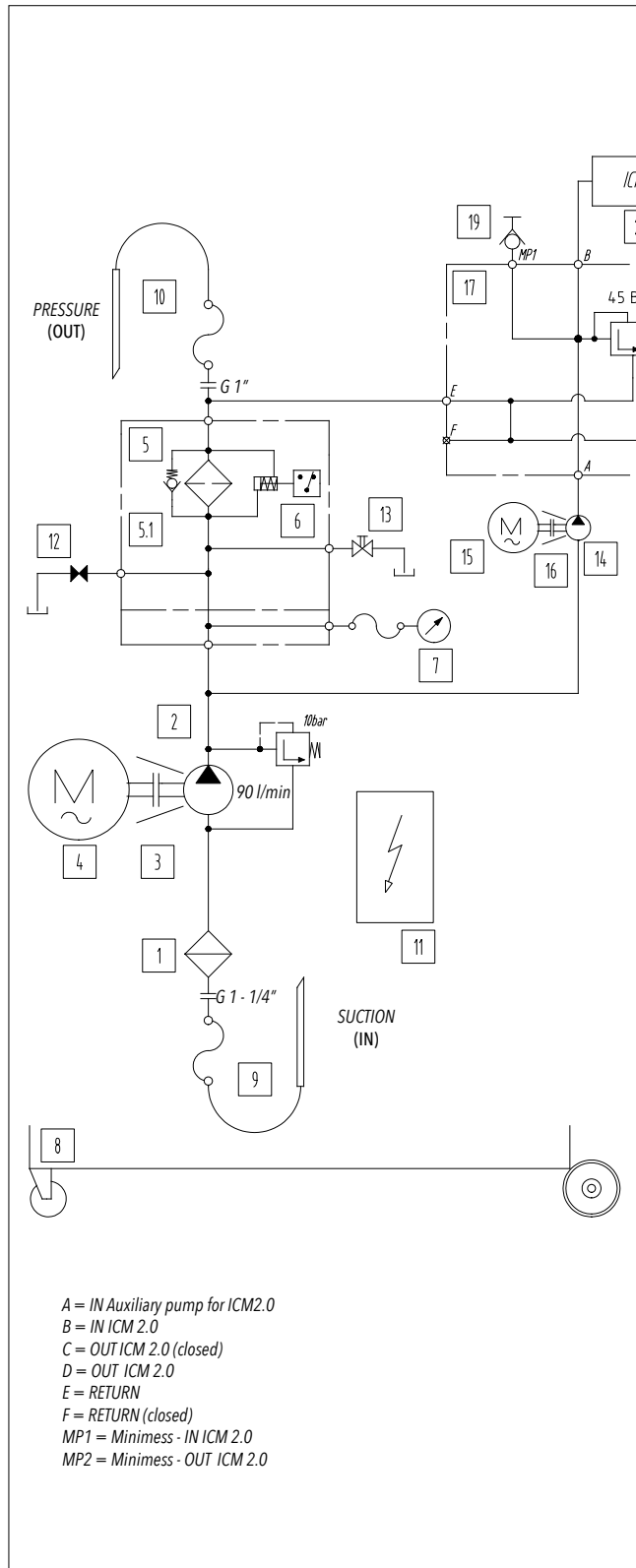

Version:
UFM091TA3021P01

Position	Quantity	Description
1	1	Y shaped filter 800 µm
2	1	Gear pump / screw
3	1	Motor/pump coupling
4	1	Three-phase electric motor 1.5 kW 4P-B3/B5 (IE3)
5	1	Increased filter length
5.1	1	Microfibre filter element 1 µm Microfibre filter element 3 µm Microfibre filter element 6 µm Microfibre filter element 10 µm Microfibre filter element 16 µm Microfibre filter element 25 µm Filter element in wire mesh 25 µm Filter element in wire mesh 60 µm Water absorber filter element
6	1	Electric diff. pressure indicator (visual indication on panel)
7	1	Pressure gauge
8	1	Mobile unit frame
9	1	DN50 flexible suction hose + nozzle
10	1	DN38 flexible discharge hose + nozzle
11	1	Electrical panel three-phase version
12	1	Drain valve
13	1	Air vent valve
14	1	Gear pump
15	1	Single-phase electric motor 0.18 kW 4P-B3/B5
16	1	Monoblock
17	2	Relief valve
18	1	Motor/pump coupling
19	1	Particle counter
20	1	Communication module

NOTE

Microfibre filter elements with water absorber: disposable components

NOTE

6 Installation procedures and general operation

6.1 Introduction

The mobile filtration units are suitable for the following fluid operations:

- Transfer with filtration
- Off-line filtration (recommended volume up to 1500/1800L)

The standard version of the filtration unit is delivered without a filter element, before its use install an original MP Filtri filter element suitable for the type of unit being used (see filter element codes listed in Table 6.7.2 Item.5) and carry out the procedures described in Section 6.2 "Filter element installation".

The filter bypass valve can be locked by replacing the endcap with bypass (Fig. 2) with the included (Fig. 1) blind endcap (Fig. 3).

The endcap is inserted into the filter element.



Scope of supply

Fig.1



Endcap with bypass

Fig.2



Blind endcap

Fig.3

With the bypass valve blocked pay close attention to the clogging indicator. As soon as the indicator indicates the clogged filter, turn off the filtration unit and replace the filter element.



CAUTION

6.2 Filter element installation

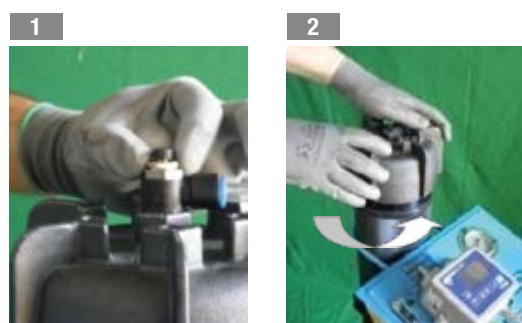

Loosen the air vent nut

Unscrew the cover



Choose the endcap with bypass or blind endcap

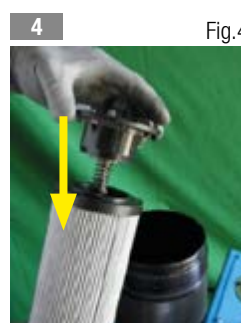

Insert the endcap with bypass (Fig. 4) or the possibly selected blind endcap (Fig. 5) in the filter element



Insert the filter element into the filter body

Screw on the cover



Make sure the air vent is closed

These operations must be performed with the machine off. Do not turn on the unit without first installing the filter element.



CAUTION

We recommend using only original MP Filtri filter cartridges.



NOTE

UFM091

6.3 Wiring diagram

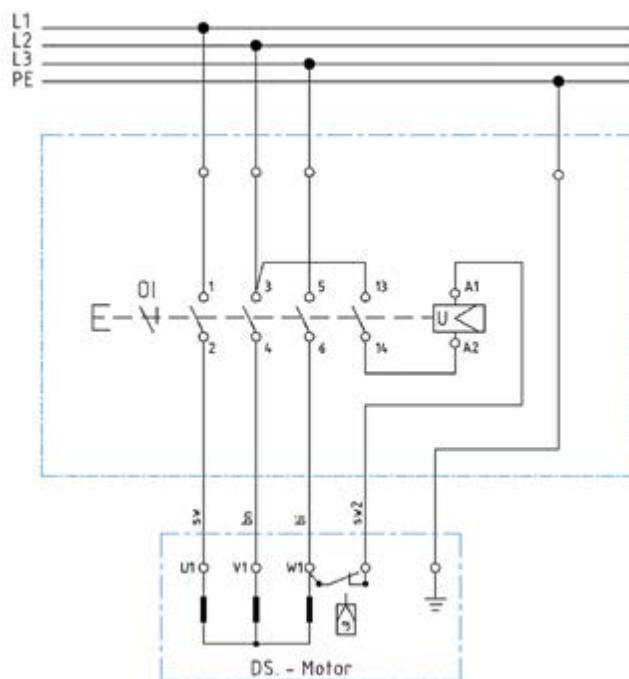

6.3.1 Electrical connection

The trolley must be connected via the plug supplied to the power supply, checking:

- the laws and technical specifications valid in the place and at the time of installation
- that the power supply voltage and the frequency at the connection point are compatible with those indicated on the rating plate of the mobile filtration unit
- the data shown on the rating plate.

It is recommended to use a multi-wire cable with a minimum cross-section of $4 \times 2.5 \text{ mm}^2$ for the connection of the electric motor.

The red plug indicates a three-phase motor, the blue plug a single-phase motor.

The supply voltage must correspond to the voltage specified on the rating plate.

The construction features of the electric cable guarantee great flexibility, excellent resistance to weather conditions, oils and greases, mechanical and thermal stresses: Standard IMQ-CPT-007, CEI EN 50525-2-2.

Compliant with requirements of the BT 2006/95/CE directives.

The terminal box contains metal elements that are under hazardous voltage; after making the connections, always close the box cover.



NOTE

6.3.2 Triangular electrical connection of a three-phase motor

This motor is connected to the three-phase line, which can be 230 V or more commonly 400 V. Since the windings that make up the motor must be powered at 230 V, the connection must be made in the following manner:

- *Delta connection: this connection applies the same voltage to the windings as to the line.*

To be able to change the direction of rotation it is sufficient to invert two phases by acting directly on the appropriate five-pole CE plug (see photo on the right).

Trolley with particle counter (see fig. 7 on page 23)



6.3.3 Electrical connection of a single-phase motor - not applicable for UFM091

6.3.4 Electrical panel

Version with three-phase motor



UFM091TA2020P01



UFM091TA3020P01

Version with three-phase motor and particle counter



UFM091TA3021P01

Labels on the electrical panel

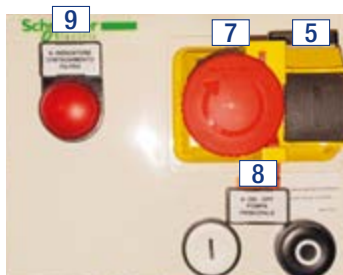

Version with electric differential indicator, red led alarm (9) on panel



Version with electric differential indicator, blue led alarm (9) on panel (for particle counter's version only)

6.3.5 Electrical panel labels

NOTE

Pos.	Translation of electrical panel labels				
	ENGLISH	ITALIAN	FRENCH	GERMAN	SPANISH
1	VOLTAGE ON	TENSIONE	APPAREIL SOUS TENSION	SPANNUNG EIN	TENSIÓN ACTIVA
2	PHASE REVERSE	FASE ROVESCIA	INVERSION DE PHASE	PHASENUMKEHR	INVERSIÓN FASE
3	ICM ALARM	ALLARME ICM	ALARME ICM	ALARM ICM	ALARMA ICM
4	THERMAL ALARM	TERMICO	ALARME THERMIQUE	WÄRMEALARM	ALARMA TÉRMICA
5	ON-OFF GENERAL	ACCESO/SPENTO	INTERRUPTEUR MARCHÉ/ ARRÊT GÉNÉRAL	EIN-/AUSSCHALTER	ON-OFF GENERAL
6	PHASE INVERTER	INVERTITORE DI FASE	INVERSEUR DE PHASE	PHASENUMKEHRSCALTUNG	INVERSOR FASE
7	EMERGENCY STOP	STOP EMERGENZA	ARRÊT D'URGENCE	NOTABSCHALTUNG	PARADA EMERGENCIA
8	ON-OFF MAIN PUMP	ON-OFF POMPA PRINCIPALE	MARCHE/ARRÊT POMPE PRINCIPALE	EIN-AUS HAUPTPUMPE	ON-OFF BOMBA PRINCIPAL
9	FILTER ELEMENT CLOGGING	INDICATORE D'INTASAMENTO FILTRO	ÉLÉMENT FILTRANT OBSTRUÉ	FILTEREINSATZ VERSTOPFT	ATASCO ELEMENTO FILTRO
10	ON-OFF COUNTER AND AUXILIARY PUMP	ON-OFF CONTATORE E POMPA SECONDARIA	MARCHE/ARRÊT COMPTEUR ET POMPE AUXILIAIRE	EIN-AUS ZÄHLER UND HILFSPUMPE	ON-OFF CONTADOR Y BOMBA AUXILIAR

The mobile filtration unit is supplied with labels in English

NOTE

UFM091

6.4 Use

6.4.1 Installation

The mobile filtration unit must be positioned in a place that guarantees its stability during use.

TRANSFER

Connect/immerse the metal suction lance (IN) to the tank or to the drum, immerse the discharge hose (OUT) in the machine tank or in the drum which should be transferred to.

If the transfer oil has to be cleaned, it is advisable to filter the oil contained in the drum or tank several times before being transferred. In this case immerse the metal suction lances (IN) and the discharge lances (OUT) in the drum or oil tank to be transferred. Be careful that the lances remain below the level of the oil to be transferred in order to avoid foaming and cavitation; space the ends of the two lances as far as possible from each other in order to recirculate all the fluid and not generate an emulsion.

FILTRATION

Immerse the metal suction lances (IN) and the discharge lance (OUT) inside the tank far from each other, possibly positioning them at different heights (100 mm suction from the bottom of the tanks, immersed flow for a minimum of 200 mm).

Make sure that the tubes/lances are properly fixed or perfectly stable before starting.

Be careful not to mix up the suction and discharge hoses. The suction hose (IN) is the one with the largest diameter.

The discharge lance must in general have unrestricted flow. It is prohibited to install taps or components on both hoses that may obstruct or reduce the flow of the fluid.



6.4.2 Power on

Insert the electric plug into a three-phase socket (Fig. 6) depending on the version (check the voltage).

Check the direction of rotation in the version with three-phase motor: Operate the switch for a few seconds and observe the direction of rotation of the electric motor. The direction observed on the fan side must be clockwise, otherwise the phases L1 and L2 must be inverted (Fig. 7). **NOTE**

Three-phase electric power supply with protective conductor is required for the power supply of the trolley.



Electrical connection for the three-phase motor (5 poles plug) Fig. 6

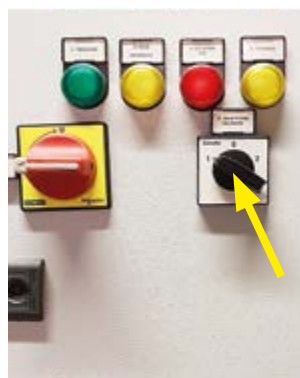

Phase inverter only for version with ICM2.0 particle counter Fig. 7



5 poles plug for the three-phase motor

Before starting up the electric motor, make sure that the suction lance (IN) is immersed in the fluid.



Operate the switch for a few seconds and observe the direction of rotation. The direction observed on the fan side must be clockwise, otherwise the phases L1 and L2 must be inverted.

NOTE

Models:
UFM091TA2020P01

After inserting the plug, turn the rotary knob for turning on and off located on the terminal box of the electric motor to "I" (Fig. 8).
At this point the transfer and filtration of the fluid begins.

Rotary knob
ON/OFF



With visual display Fig.8

Models:
UFM091TA3020P01

Once the plug has been inserted, press the button a Fig. 9 (general power supply), press the ignition switch "I" on the electrical panel (Fig. 10).
At this point the transfer and filtration of the fluid begins.

Button
general power supply



With electric indicator Fig.9

Button
ON/OFF



With electric indicator Fig.10

Models:
UFM091TA3021P01

Once inserted, turn the switch to "I" (Fig. 11 - General power supply), then press the on button "I" on the electrical panel (Fig. 12).
At this point the transfer and filtration of the fluid begins.

Button
general power supply



With electric indicator and particle counter Fig.11

Button
ON/OFF



With electric indicator and particle counter Fig.12

UFM091

6.4.3 Air vent

When the unit is first turned on after inserting the filter element, vent the air inside the filter body using the vent valve (Fig. 13) on the cover. Once the air has been removed, close the vent valve.



Air vent Fig.13

Collect the oil in a container and dispose of it in accordance with the regulations in force.



NOTE

6.4.4 Oil analysis with particle counter

The ICMWMKUG12.0 series particle counter versions allow contamination counting and classification according to the international standards ISO 4406 - NAS 1638 - AS4059 Tab.1 - AS4059 Tab.2.

The particle counter also supplies the value of the water content in the oil and the temperature via an internal sensor.

It is possible to program the particle counter by connecting it via the ICMUSBI module (supplied) to a Personal Computer.

It is possible to enter a default value for the cleanliness class (according to the regulations used).

NOTE

When this value is reached, the unit switches off automatically.



Motor/pump assembly and pressure relief valves for the use of the particle counter



Start/Stop auxiliary pump for particle counter Fig.14



Manual activation of particle counter Fig.15

To commission the ICM, switch on the auxiliary pump and the particle counter using the selector in the electrical panel (Fig. 14), then wait 5 minutes after switching on before counting. To carry out the count, activate the particle counter button (Fig. 15).

Before starting the particle counter auxiliary pump, make sure that the main pump has been running for about 5-6 minutes and that the hoses are full of oil.



CAUTION

For more technical details please refer to the documentation available on the website www.mpfiltri.com and downloadable via QR-Codes on page 13.

NOTE

6.4.5 Shutdown

Models:
UFM091TA2020P011

Once the operations have been completed, switch off the electric pump, turn the switch-off knob to "0" on the terminal box of the electric motor (Fig. 16) and disconnect the electrical connection plug.

Rotary knob
ON/OFF



With visual display Fig.16

Models:
UFM091TA3021P01

Once the operations have been completed, switch off the electric pump, press the shutdown button to "0" on the electrical panel (Fig. 17) and disconnect the electrical connection plug.

Button
ON/OFF



With electric indicator Fig.17

Models:
UFM091TA3021P01

Once the operations have been completed, switch off the electric pump, press the button "0" on the electrical panel (Fig. 18), turn the shutdown switch to "0" (Fig. 19 - General power supply) and disconnect the electrical connection plug.

If the particle counter is used, switch off the auxiliary unit before the main electric pump by turning the pump shut-off switch (Fig. 20).

Button
ON/OFF



With electric indicator and particle counter Fig.18

Button
general power supply



With electric indicator and particle counter Fig.19

Button
ON/OFF



With electric indicator and particle counter Fig.20

UFM091

Put the lances in their respective housings (⚠ - Fig. 21), anchored to the frame paying attention to the fluid still present in the hoses.

Rewind the power supply cable.



Lance holders Fig.21

The UFM091 is equipped with a thermal protection device against electrical overloads, short circuits and overheating. If a "BLOCK" occurs, check the operating conditions (e.g. clogged filter, fluid conditions, motor overheating, etc.) and reset the thermal protection by pressing the appropriate button on the side of the motor terminal box.

With oil temperatures above 40/45 °C, give special caution to the handling of the metal lances/tubes and movement of the trolley. Avoid direct contact with hot oil, the mobile filtration unit and its installed components.



6.4.6 Operating limits and environmental limits

The trolley is designed to operate at a maximum pressure of 10 bar.

The electric motor is designed to operate according to the rating plate data.

For use in environments with very cold or very hot temperatures, refer to the technical data provided in Section 5.

6.5 Normal and scheduled maintenance

The UFM091 does not require particular maintenance interventions, it is in any case a good rule to check the perfect condition of the suction and discharge hoses before each use. Check that the filter element is correctly installed and that the filter cover is tightly screwed on.

Periodically check the tightness of the hydraulic connections and if the electrical cable ends in the motor terminal box are tight. Also check the cleanliness of the "Y" shaped filter for any accumulated macro impurities, so as to preserve the filter element (CU4006). Check the expiration date of the particle counter calibration certificate.

To keep the efficiency of the particle counter high, it is advisable to send it once a year to our headquarters for inspection, monitoring, testing on the test bench and issuing a new calibration certificate.



6.5.1 Oil leaks

Oil leaks can form on the joints of the hoses and on fittings if any connections or screws are loosened, in which case we recommend checking the correct tightness.

If the operations described above are not able to solve the problem, contact the manufacturer.

6.6 Filter clogging

- *Versions with visual differential clogging indicator*
UFM091TA2020P01

The conditions relating to the blockage of the filter element are guaranteed by a visual indicator (Fig. 22) mounted on the head of the LMP430 filter. When the differential pressure of 3 bar is reached, the red alarm piston is visible. Replace the filter element.

- *Versions with electric differential pressure indicator for blockage*
UFM091TA3020P01 - UFM091TA3021P01

The conditions related to the blockage of the filter element are ensured by an electric indicator (Fig. 23) mounted on the head of the LMP430 filter. When the differential pressure of 3 bar is reached, the electric signal switches off the machine and turns on the light on the electrical panel. Replace the filter element.

All models are equipped with a pressure gauge (Fig. 24) with 10 bar full scale to measure the circuit pressure. For signalling the clogged filter, refer to the differential pressure indicators. The LMP430 filter is equipped with a bypass valve with a response pressure set at 3.5 bar.



Version with visual indicator

Fig.22



Version with electric indicator

Fig.23



Pressure gauge

Fig.24

It is recommended to never exceed the response pressure of the bypass valve (3.5 bar).



6.6.1 Replacing the filter element

Before proceeding with the replacement of the filter element, make sure that the oil temperature is lower than +40/45 °C. Replace the filter element whenever necessary, i.e. whenever the differential pressure indicator indicates a clogged filter or when different fluids must be filtered.

The filtration of the filter element takes place from the outside to the inside, drain the residual oil into the body as it is not normally clean.

The oil must always be emptied using the drain valve (Fig. 25) located at the base of the filter body, clean the inside of the container.

UFM091

It is recommended to clean the filter cover carefully before beginning the operations for replacing the filter element.

- 1**



Open the vent valve
- 2** Fig.25



Drain the oil using the oil drain
- 3**



Unscrew the filter cover
- 4**



Remove the filter element
- 5**



Remove the bypass or blind endcap
- 6**



Make sure the container is securely tightened
- 7** Fig.26



Insert the endcap with bypass (Fig. 26) or the possibly used blind endcap (Fig. 27) in the new filter element
- 7** Fig.27



- 8**



Insert the new filter element
- 9**



Screw on the cover
- 10**



Close the air vent

Collect the replaced oil and filter element in a container and dispose of it in accordance with the regulations in force.



Any intervention must be carried out with the machine off. Always remember to unplug the power supply.



6.6.2 Air vent

When the unit is first turned on after replacing the filter element, drain the air inside the filter body using the vent valve (Fig. 28) on the cover. Once the air has been removed, close the vent valve.



Air vent

Fig.28

Collect the oil in a container and dispose of it in accordance with the regulations in force.



NOTE

6.6.3 Replacing and cleaning of the filter in the suction line

Regularly (every 6 months or if you hear pump cavitation noises) check the blockage status of the suction filter and clean or replace it if necessary.



Suction filter



Unscrew the nut and remove the filter element

Collect the replaced oil and filter element in a container and dispose of it in accordance with the regulations in force.



NOTE

Any intervention must be carried out with the machine off. Always remember to unplug the power supply.



CAUTION

UFM091

7 Designation & ordering code

MOBILE FILTRATION UNIT										
Series UFM	Configuration example:	UFM	091	T	A	2	0	2	0	P01
Size 091 90 l/min										
Electric motor T 400/230 V Three phase										
Seals A NBR										
Pressure gauges and Clogging indicators (see below) 2 Manometer (*) + Visual differential clogging indicator 3 Manometer (*) + Electrical diff. clogging indicator (visual indication on panel)										
Filter element 0 Without element (for ordering, see below)										
Filtration surface 2 Higher										
Option 0 No options 1 ICM 2.0 particle counter										
Option P01 MP Filtri standard Pxx Customized										

Filtration element should be ordered separately

FILTRATION RATING		WATER ABSORBER	
Inorganic microfibre	Wire mesh element	Multi-Layer water absorber	
CU 400 6 A01 A N P01 01 µm	CU 400 6 M25 A N P01 25 µm	CU 400 6 WA025 A N P01 25 µm	
CU 400 6 A03 A N P01 03 µm	CU 400 6 M60 A N P01 60 µm		
CU 400 6 A06 A N P01 06 µm			
CU 400 6 A10 A N P01 10 µm			
CU 400 6 A16 A N P01 16 µm			
CU 400 6 A25 A N P01 25 µm			

CLOGGING INDICATORS (*)			
DVM Visual Differential Indicator		DEA Electrical Differential Indicator (visual indication on panel)	
Settings	Ordering code	Settings	Ordering code
3.0 bar ±10%	DV M 30 P01	3.0 bar ±10%	DE A 30 P01

8 Spare parts

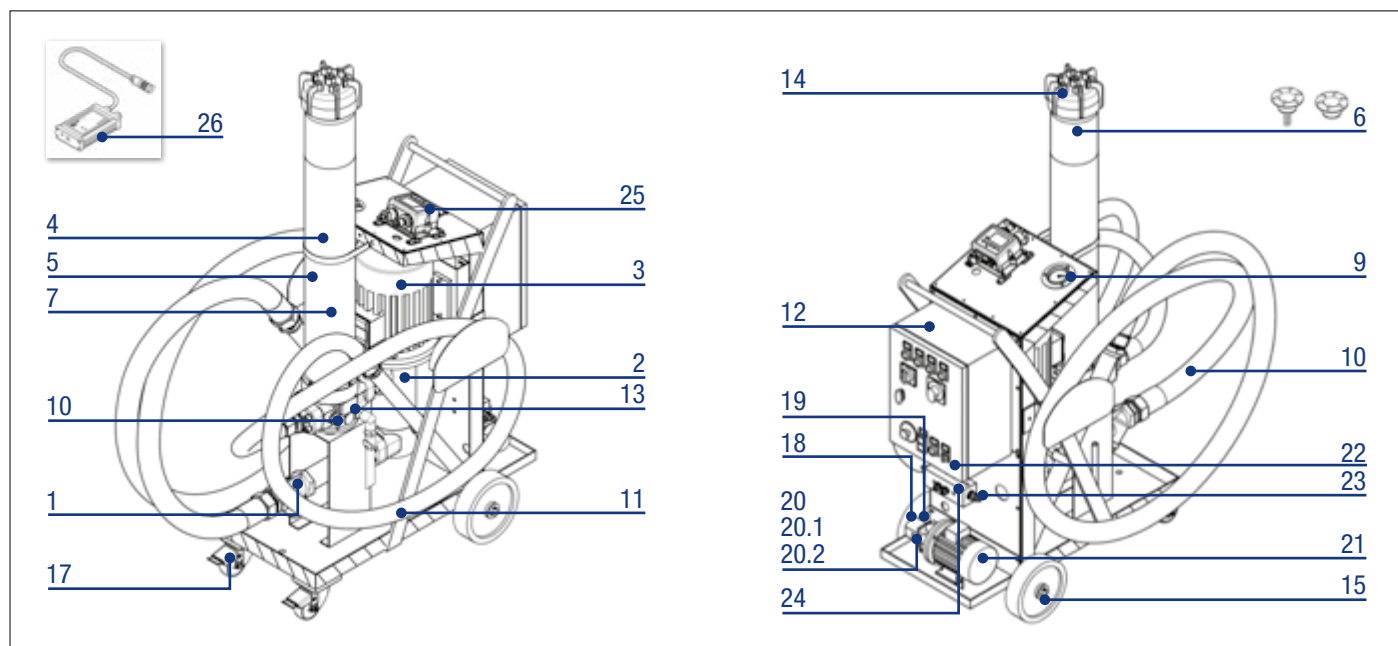

8.1 List of spare parts

Position	Series	Description	Code	Quantity
1	UFM091TA2020P01 UFM091TA3020P01 UFM091TA3021P01	Y-shaped filter 2" BSP - 800 µm	02200041	1
2	UFM091TA2020P01 UFM091TA3020P01 UFM091TA3021P01	GR45 SMT16B-180L/AC28 B5 RF3 Screw pump with integrated pressure relief valve	02200042	1
3	UFM091TA2020P01 UFM091TA3020P01 UFM091TA3021P01	3-phase el. motor 2.2 kW 4P B3B5 IP55 3F 230/400V 50/60Hz CLASS IE3	02200028	1
4	UFM091TA2020P01 UFM091TA3020P01 UFM091TA3021P01	Increased filter length	LMP4306BAF1P02	1
5	UFM091TA2020P01 UFM091TA3020P01 UFM091TA3021P01	Microfibre filter element 1 µm Microfibre filter element 3 µm Microfibre filter element 6 µm Microfibre filter element 10 µm Microfibre filter element 16 µm Microfibre filter element 25 µm Filter element in wire mesh 25 µm Filter element in wire mesh 60 µm Water absorber filter element	CU4006A01ANP01 CU4006A03ANP01 CU4006A06ANP01 CU4006A10ANP01 CU4006A16ANP01 CU4006A25ANP01 CU4006M25ANP01 CU4006M60ANP01 CU4006WA025ANP01	1
6	UFM091TA2020P01 UFM091TA3020P01 UFM091TA3021P01	Endcap with 3.5 bar bypass	02001414	1
		Blind endcap without bypass	01044108	
7	UFM091TA2020P01 UFM091TA3020P01 UFM091TA3021P01	Gasket kit for LMP430 filter	02050393	1
8	UFM091TA2020P01	Visual differential pressure indicator	DVM30HP01	1
	UFM091TA3020P01 UFM091TA3021P01	Electric differential pressure indicator (visual indication on panel)	DEA30HA50P01	

UFM091

Position	Series	Description	Code	Quantity
9	UFM091TA2020P01 UFM091TA3020P01 UFM091TA3021P01	Pressure gauge	MGF63G10	1
10	UFM091TA2020P01 UFM091TA3020P01 UFM091TA3021P01	Flexible suction hose DN50 L = 3000mm Inclined cut nozzle Øe = 50 L = 700mm	02200044	1
11	UFM091TA2020P01 UFM091TA3020P01 UFM091TA3021P01	Flexible delivery hose DN38 L = 3000mm Inclined cut nozzle Øe = 42 L = 700mm	02200043	1
12	UFM091TA2020P01	Electrical panel three-phase version + cable and CEE plug	02200029	1
	UFM091TA3020P01		02200030	
	UFM091TA3021P01		02200031	
13	UFM091TA2020P01 UFM091TA3020P01 UFM091TA3021P01	Drain valve	02200039	1
14	UFM091TA2020P01 UFM091TA3020P01 UFM091TA3021P01	Air vent valve	02200040	1
15	UFM091TA2020P01 UFM091TA3020P01 UFM091TA3021P01	Fixed wheel Ø200x50x20 mm. Blue polyurethane coating and black polyamide structure	02200045	2
16	UFM091TA2020P01 UFM091TA3020P01 UFM091TA3021P01	Swivel wheel with Ø80x30x20 mm lock. Blue polyurethane coating and black polyamide structure	02200046	1
17	UFM091TA2020P01 UFM091TA3020P01 UFM091TA3021P01	Swivel wheel Ø80x30x20 mm. Blue polyurethane coating and black polyamide structure	02200047	1
18	UFM091TA3021P01	025-D-18 gear pump	02200048	1
19	UFM091TA3021P01	Pump bracket	LMG140MFS05M4SANU	1
20	UFM091TA3021P01	Pump side half-coupling	SGEA01FS05M	1
20.1	UFM091TA3021P01	Motor side half-coupling	SGEA01M01021FG	1
20.2	UFM091TA3021P01	Elastic wheel	EGEO	1
21	UFM091TA3021P01	Single-phase electric motor 0.18 kW 4P B3/B5 CLASS IE3	02200049	1
22	UFM091TA3021P01	Valve lock	02200050	1
23	UFM091TA3021P01	Relief valve	02200051	2
24	UFM091TA3021P01	1/4" pressure mini-plug	02200052	2
25	UFM091TA3021P01	Particle counter	ICMWMKUG12.0	1
26	UFM091TA3021P01	Communication module	ICMUSBI	1
27	UFM091TA2020P01 UFM091TA3020P01 UFM091TA3021P01	Adapter for 5 to 4 poles plug for the three-phase motor	xxxxxxx	1

8.2 Filter element detail

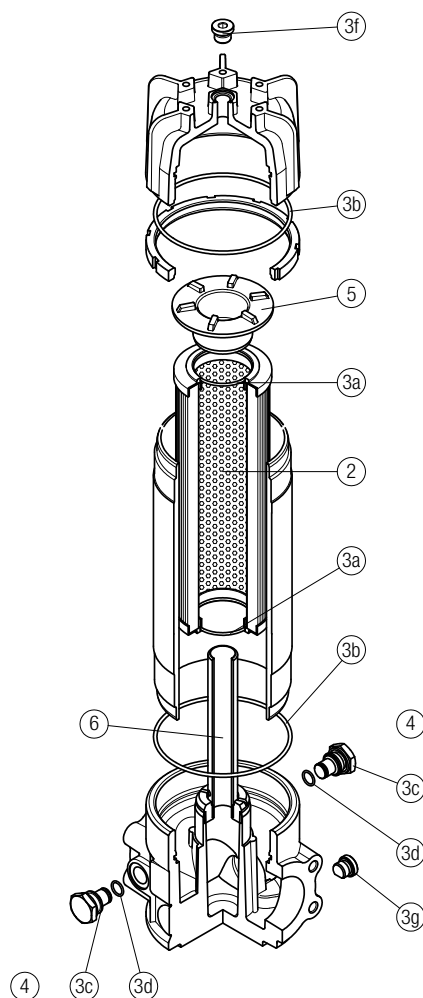

Item:	Q.ty: 1 pc.	Q.ty: 1 pc.	Q.ty: 2 pcs.	Q.ty: 2 pcs.	Q.ty: 1 pc.
Filter series	Filter element	Seal Kit code number NBR FPM	Indicator connection plug NBR FPM	Housing spigot no bypass with bypass	Internal tube for low flow rate, execution P02
LMP 430 length 6	See spare parts (position 5)	02050393 02050394 (included with filter element)	T2H T2V	01044108 02001414	02025042

All data, details and words contained in this publication are provided for use by technically qualified personnel at their discretion, without warranty of any kind.

MP Filtri reserves the right to make modifications to the models and versions of the described products at any time for both technical and/or commercial reasons.

For updated information please visit our website: www.mpfiltri.com

The colors and the pictures of the products are purely indicative.

Any reproduction, partial or total, of this document is strictly forbidden.

All rights are strictly reserved

WORLDWIDE NETWORK

CANADA ♦ CHINA ♦ FRANCE ♦ GERMANY ♦ INDIA ♦ SINGAPORE
UNITED ARAB EMIRATES ♦ UNITED KINGDOM ♦ USA



PASSION  PERFORM

in @ y f



mpfiltri.com
Scan or click me!