

# MOBILE FILTRATION UNIT

INSTALLATION,  
SERVICE AND  
MAINTENANCE  
MANUAL  
AND SAFETY  
INSTRUCTIONS

## UFM041



EN

PASSION  PERFORM





# PRODUCT OVERVIEW

## UFM041 filtration unit series

### Key features:

- Transfer
- Filtration
- Flow rates 34 l/min
- Maximum working pressure 5 bar
- Absolute filtration
- Wide range of filtration media
- Water removal filter elements
- Single-phase and three-phase motors
- Comprehensive choice of configurations
- Equipped with handles and wheels for easy portability
- CE standard





# DECLARATION OF CONFORMITY

## CE EC declaration DECLARATION OF CONFORMITY IN ACCORDANCE WITH 2006/42/EC MACHINERY DIRECTIVE

The company:

**MP Filtri S.p.A.**  
**Via 1° Maggio, 3**  
**20042 - Pessano con Bornago (MI) - Italy**

as a manufacturer, it declares that the machine:

Name	Code / Model
MOBILE FILTRATION UNIT	UFM041MA1010P01 UFM041TA1010P01

to which this declaration refers, complies with the following Directives: **2006/42/EC Machinery Directive.**

Furthermore, the technical documentation was compiled in accordance with **Annex VII Part A.**

The machine also complies with the provisions of the following standards:

- UNI EN ISO 12100-1-2:2010 Safety of machinery
- UNI EN ISO 13857:2008 Safety of machinery - Safety distances to prevent the reaching into dangerous areas with the upper and lower limbs
- UNI EN ISO 13732-1:2009 Ergonomics of thermal environments - Methods for evaluating human response to contact with surfaces
- UNI EN ISO 4413:2012 Hydraulics - General rules and safety requirements for systems and their components

Pessano con Bornago, 14/05/2019

Chief Executive Officer  
CEO



	Page
<b>PRODUCT OVERVIEW</b>	<b>1</b>
Declaration of Conformity	3
Table of contents	4
<b>GENERAL WARNINGS</b>	
<b>1 General warnings and information for the recipient</b>	<b>6</b>
1.1 General information	6
1.2 General and safety instructions	6
1.3 Operator station and dangerous areas	8
1.4 Hazards and risks that cannot be eliminated	8
1.5 Personal protective equipment	8
<b>TRANSPORT AND STORAGE</b>	
<b>2 Transport and handling conditions</b>	<b>8</b>
<b>GENERAL WARRANTY CONDITIONS</b>	
<b>3 Warranty, limits and exclusions</b>	<b>9</b>
<b>PRODUCT DOCUMENTATION</b>	
<b>4 Mobile transfer and filtration units</b>	<b>10</b>
4.1 Test certificate	11
4.2 Download Area	11

# TABLE OF CONTENTS

	Page
<b>5 Technical features</b>	<b>13</b>
5.1 Dimensions	14
5.2 Hydraulics diagrams and material list	15
<b>6 Installation procedures and general operation</b>	<b>16</b>
6.1 Introduction	16
6.2 Filter element installation	16
6.3 Wiring diagram	17
6.3.1 Electrical connection	17
6.3.2 Triangular electrical connection of a three-phase motor	17
6.3.3 Electrical connection of a single-phase motor	18
6.3.4 Electrical panel	18
6.3.5 Electrical panel labels	-
6.4 Use	18
6.4.1 Installation	18
6.4.2 Power on	19
6.4.3 Air vent	-
6.4.4 Oil analysis with particle counter	-
6.4.5 Shutdown	20
6.4.6 Operating limits and environmental limits	20
6.5 Normal and scheduled maintenance	20
6.5.1 Oil leaks	21
6.6 Filter clogging	21
6.6.1 Replacing filter element	21
6.6.2 Air vent	-
6.6.3 Replacing and cleaning of the filter in the suction line	23
<b>7 Designation &amp; ordering code</b>	<b>24</b>
<b>8 Spare parts</b>	<b>26</b>
8.1 List of spare parts	27
8.2 Filter element detail	28

# 1. General warnings and information for the recipient

## 1.1 General information

The mobile filtration units of the UFM series have been designed and manufactured in compliance with the machinery directive and the low voltage directive with regards to electric motors. The EC Declaration of Conformity is included in this manual.

The warranty has a duration of twelve months starting from the date shown on the delivery note. To consulte “General Warranty Conditions” section of this Use and Maintenance Manual.

## 1.2 General and safety instructions

Read this manual carefully before commissioning, maintenance or other activities on or with the unit. Each operator involved in the operation of the mobile filtration unit must wear the following personal protective equipment:



Safety glasses



Safety shoes



Gloves

Before carrying out any installation or work on and/or with the machine it is necessary to strictly follow the instructions listed in this manual. It is also necessary to comply with the provisions in force concerning accident prevention and safety in the workplace. The warnings to prevent dangers to the health of the personnel assigned to the machine, are highlighted in this documentation with signal words to notifications:

If important information concerning the product affects the use of the product or a part of this documentation, all of it must be particularly taken into account.



*NOTE*

This means that failure to comply with the relevant safety regulations may result in slight injury or damage to equipment.



*CAUTION*

This means that failure to comply with the relevant safety regulations can result in death, serious injury or considerable damage to equipment.



*DANGER*

# GENERAL WARNINGS

To allow rapid identification of the employees who must read this manual, definitions have been used with the following meaning:

OPERATOR	The person in charge of using the machine for productive purposes. The operator is aware of the measures taken by the machine manufacturer to eliminate the sources of risk of accidents at work and complies with the operational constraints.
PERSONNEL INVOLVED IN SLINGING AND HOISTING OPERATIONS	The person in charge of handling the machine or parts thereof. The slinger is aware of the problems concerning the transport of machines or parts thereof in safe conditions; for this purpose, they use lifting equipment suitable for the purpose following the instructions provided by the machine manufacturer.
MACHINE SETTER	The person in charge of preparing the machine for normal operation. The machine setter is aware of the measures taken by the machine manufacturer to eliminate the sources of risk of accidents at work and complies with the operational constraints. The machine setter takes the necessary precautions to intervene in conditions of maximum safety.
MAINTENANCE TECHNICIAN	The person in charge of performing maintenance operations on the machine. The maintenance technician is aware of the possible dangerous situations that may arise during his work and takes the necessary precautions to avoid risks of accidents at work.
ELECTRICIAN	The person in charge of carrying out maintenance operations on the machine's electrical system. The electrician is aware of the possible dangerous situations that may arise during his work and takes appropriate precautions to avoid risks of accidents at work.

### 1.3 Operator station and dangerous areas

Areas adjacent to the electric motor due to the presence of live equipment and potentially very hot surfaces are to be considered as dangerous areas. The operator has no reason to access electrical equipment and is not authorised to do so.

The trolley must be taken out of service and/or dismantled in full compliance with the regulations in force at that time in the country where the machine is installed.



NOTE

The machine is not suitable for outdoor use and all electrical equipment has a minimum degree of protection IP 55.



NOTE

### 1.4 Hazards and risks that cannot be eliminated

Risk of electric shock on the electric motor, in case of motor malfunction, risk of burns due to high temperature, accidental oil leakage with consequent possibility of slipping, rupture of the hoses with consequent loss of lubricant.

With oil temperatures above 40/45 °C, take extra caution in the handling of metal lances/tubes and movement of the mobile filtration unit. Avoid direct contact with hot oil and the filter housing.

### 1.5 Personal Protective Equipment

For normal use of the mobile filtration unit, safety shoes, gloves and safety glasses must be worn. In general the PPE to be used according to the operations on the machine are summarised in the following table:

OPERATION	PPE
Normal operation	Safety shoes, protective gloves, safety glasses
Normal maintenance	Safety shoes, protective gloves, safety glasses



## 2. Transport and handling conditions

The filtration unit is transported packaged with strapping and plastic film.

The product is moved by means of wheels. The movement of the same is carried out by acting on the special handle.

The weight of each individual unit is shown below:

Total weight UFM041	45 Kg
---------------------	-------

# GENERAL WARRANTY CONDITIONS

## 3. Warranty, limits and exclusions

- 1 - The seller assumes a guarantee of the normal mechanical operation of their product for a period of one year (except as provided for in Item H4 referred to the general conditions of sale and warranty sent with each order confirmation) from the delivery date.
- 2 - The warranty is limited to the replacement of damaged or defective parts due to poor quality of the material or construction. It does not extend to defects due to normal wear or due to inexperience or negligence of the customer and to parts that due to the composition of the material or the nature of their use are subject to rapid wear.
- 3 - Damage or defects must be declared, under penalty of forfeiture, by registered letter within eight days of discovery. The seller, once being aware of the existence of the defect, is obligated to replace the defective elements if they have not been tampered with due to attempted repair or modification by the customer (or third parties), and provided that he has punctually fulfilled the contractual obligations, with particular regard to payments which, if not carried out in the manner and within the agreed terms, entail the forfeiture of the guarantee and the seller's right not to effect the replacements.
- 4 - Any other indemnity, request for compensation for damages, also by third parties, due to production shutdown of the customer is expressly excluded.
- 5 - The items to be replaced must be sent with transport costs to be paid by the purchaser ex works of the seller who will replace them as soon as possible with delivery to their premises. The replaced parts belonging to the customer remain at his disposal for eight days within which they can be collected; following this deadline the seller is entitled to regard them as scrap in his possession without any compensation.
- 6 - The examination of the failures and their causes will always be carried out in the seller's workshops and all the related costs will be borne by the customer. The customer is also responsible for all inspection costs that may be requested on site. In no case may the customer demand the termination of the contract.
- 7 - The warranty is not transferable and applies only to the invoice recipient.
- 8 - The warranty is no longer valid when one of the following conditions is the case:
  - a) payments are not made by the client in the manner and terms agreed
  - b) tampering with what is provided without the seller's explicit authorisation
  - c) improper use of what is supplied
  - d) failure to perform maintenance
  - e) installation, modification, replacement of parts or of what is supplied

## 4. Mobile transfer and filtration units

The UFM series mobile filtration units are machines designed for transferring and filtering lubricants and hydraulic oils. The UFM015 version can be moved thanks to the use of handle and low weight, all other versions have wheels for moving. They can be used with fluids at different temperatures (therefore different viscosities) as long as they fall within the limits indicated by this manual. Operation with Mineral Oils, Synthetic Fluids & HFCs.

NOTE

The machine can be used for:

### *TRANSFER*

- transferring from drums into tanks
- to refill from drums into tanks

### *FILTRATION*

- off-line filtration in tanks
- additional off-line filtration system in tanks
- off-line filtration of new oil into drums or underground/large tanks
- Particle counting and determination of cleanliness class according to ISO4406, NAS1638, AS4059 (only for versions with ICM mounted on UFM051-091-181-919)
- Measurement of the water saturation level (RH) contained in the fluid and of the temperature

Depending on the version, the mobile filtration units can use filter elements and cartridges with different filtering media, filtration degree and dimensions; the fibre filter elements have high storage capacity and absolute filtration  $\beta_{x(c)} > 1000$ .

Single-phase and three-phase electric motors.

Wide range of flow rate, from 15 l/min to 180 l/min.

Optical and electrical systems for filter monitoring.

Electrical systems for greater safety:

- unit shutdown in case of clogged filter (from the UFM041 version onwards)
- unit shutdown when the set cleanliness class is reached (particle counter version only).

Before commissioning the equipment make sure:

- you have read this manual carefully
- check the good condition of the mobile filtration unit
- report any damage or breakages suffered by the mobile filtration unit during transport
- verify the presence of all the accessories supplied

# PRODUCT DOCUMENTATION

## 4.1 Test certificate

Hard copy of test certificate is attached to the cart.

## 4.2 Download Area

Please scan the QR codes below to get updated electronic version of the related document.

**MOBILE FILTRATION UNIT**  
General catalogue







 Download PDF

**CONTAMINATION MONITORING PRODUCTS** General catalogue



 Download PDF

**QUICK GUIDE**  
UFM series

 Download multi-language PDF

**USER'S MANUAL - UFM series**

    Select your language and download PDF

<p><b>UFM 015</b></p> 	<p><b>UFM 041</b></p> 	<p><b>UFM 045</b></p> 	<p><b>UFM 051</b></p> 
<p><b>UFM 091</b></p> 	<p><b>UFM 181</b></p> 	<p><b>UFM 919</b></p> 	

**CMP View Software**  
Software multilingual

Download Software







**CMP View Software**  
Quick Guide

 Select your language and download PDF

**ICM**  
User's Guide

 Select your language and download PDF



# UFM041

## 5. Technical features

The mobile filtration unit consists of a support frame with handle and wheels for manoeuvrability.  
 The assembly/motor pump connected to the hoses is used for suctioning and discharging the fluid.  
 It is equipped with a suction filter and a discharge filter.  
 The mobile filtration unit is complete with electrical safety systems for the filter and the assembly/motor pump.

Pump	External gear pump with integrated pressure relief valve
Electric motor	0.75 kW 230 V single-phase - 0.75 kW 400/230 V three-phase
Flow rate (l/min)	34 l/min -1450 rpm
Max. working pressure	5 bar
Viscosity	Minimum operating viscosity 10 cSt Maximum operating viscosity 200 cSt Maximum only for cold starts 800 cSt
Suction filter	Y-shape fine filter unit 900 µm
Type of filtering mat/degree of filtration	Fibre 1/3/6/10/16/25 $\beta_{x(c)} > 1000$
Internal/external filtration	Wire mesh 25/60 µm Water absorber <span style="float: right;">NOTE 1/NOTE 2</span>
Bypass valve $\Delta p$ set	3 bar
Fluid temperature	from -5 °C to +80 °C
Ambient temperature	from -20 °C to +45 °C
Protection class	IP 55
Seals	NBR
Compatibility with hydraulic fluids	Mineral & Synthetic oils. For other fluids contact MP Filtri.
Hoses	Flexible suction hose DN25 L = 3000 mm Nozzle $\varnothing_e = 25$ L = 700 mm Flexible delivery hose DN20 L = 3000 mm Nozzle $\varnothing_e = 20$ L = 700 mm
Weight	45 kg
Equipment	Pressure gauge

Microfibre filter elements with water absorber: disposable components

NOTE 1

The system is supplied without filter element

NOTE 2

## 5.1 Dimensions

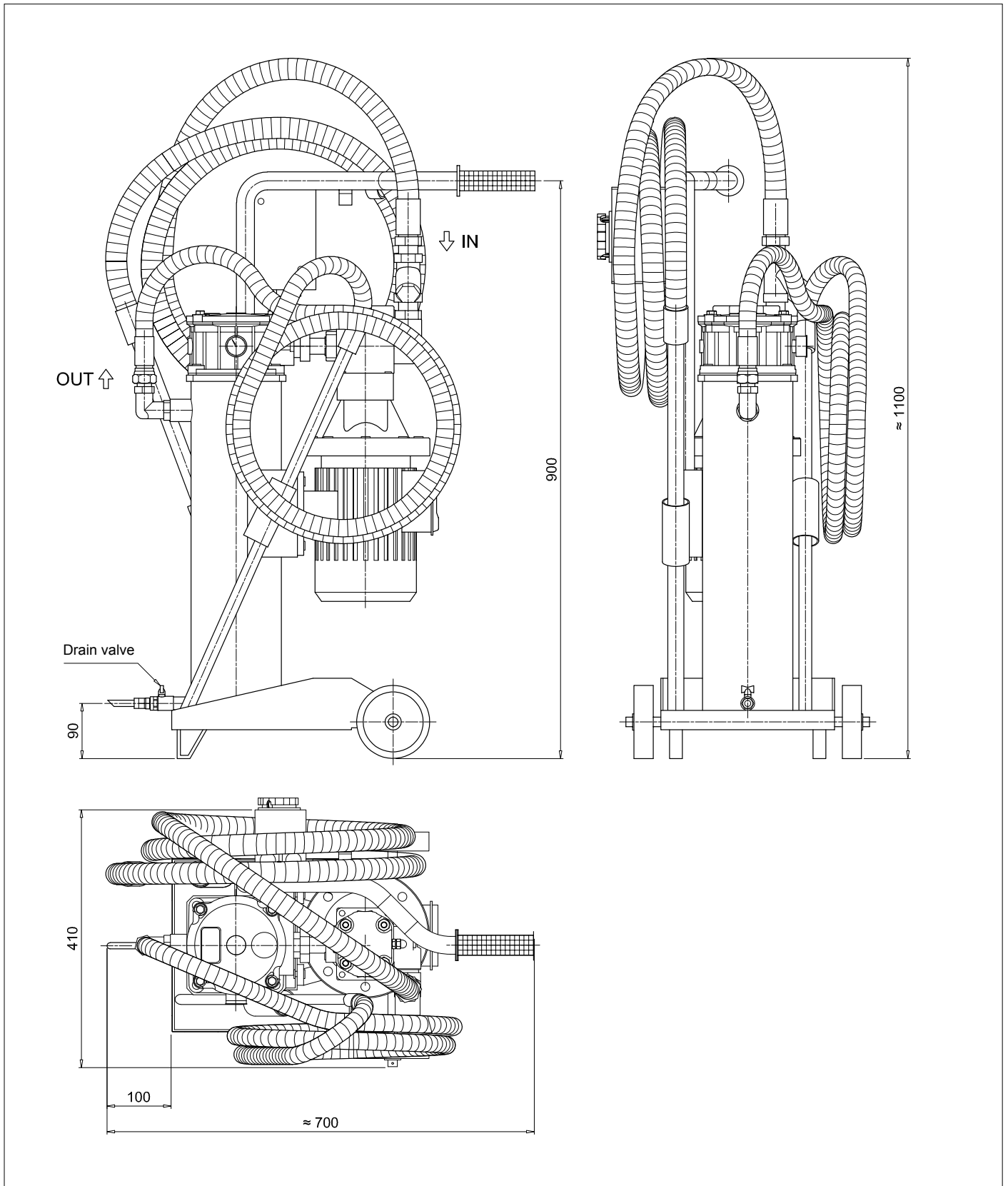

# UFM041

## 5.2 Hydraulic circuit and bill of materials

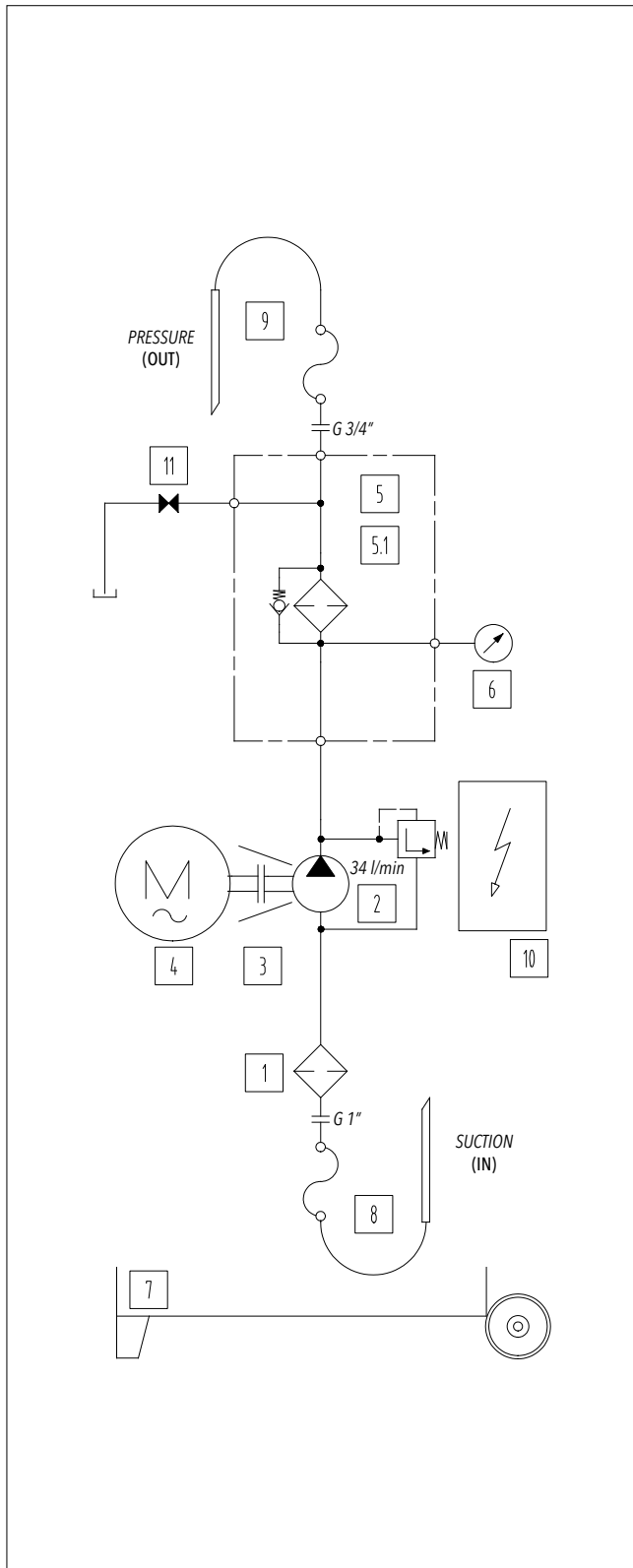

### Versions:

#### UFM041MA1010P01 - UFM041TA1010P01

Position	Quantity	Description
1	1	Y shaped filter 900 µm
2	1	Gear pump / screw
3	1	Motor/pump coupling
4	1	Single-phase electric motor 0.75 kW 4P-B3/B5 (IE3) Three-phase electric motor 0.75 kW 4P-B3/B5 (IE3)
5	1	Filter
5.1	1	Microfibre filter element 1 µm Microfibre filter element 3 µm Microfibre filter element 6 µm Microfibre filter element 10 µm Microfibre filter element 16 µm Microfibre filter element 25 µm Filter element in wire mesh 25 µm Filter element in wire mesh 60 µm Water absorber filter element
6	1	Pressure gauge
7	1	Mobile unit frame
8	1	(IN) DN25 flexible suction hose + nozzle
9	1	(OUT) Flexible DN20 pressure hose + nozzle
10	1	Electrical panel single-phase version Electrical panel three-phase version
11	1	Drain valve

**NOTE**

## 6. Installation procedures and general operation

### 6.1 Introduction

The mobile filtration units are suitable for the following fluid operations:

- Transfer with filtration
- Off-line filtration (maximum recommended volume 350/500L)

The standard version of the filtration unit is delivered without a filter element, before its use install an original MP Filtri filter element suitable for the type of unit being used (see filter element codes listed in Table 6.7.2 Item.8) and carry out the procedures described in Section 6.2 "Filter element installation".

### 6.2 Filter element installation

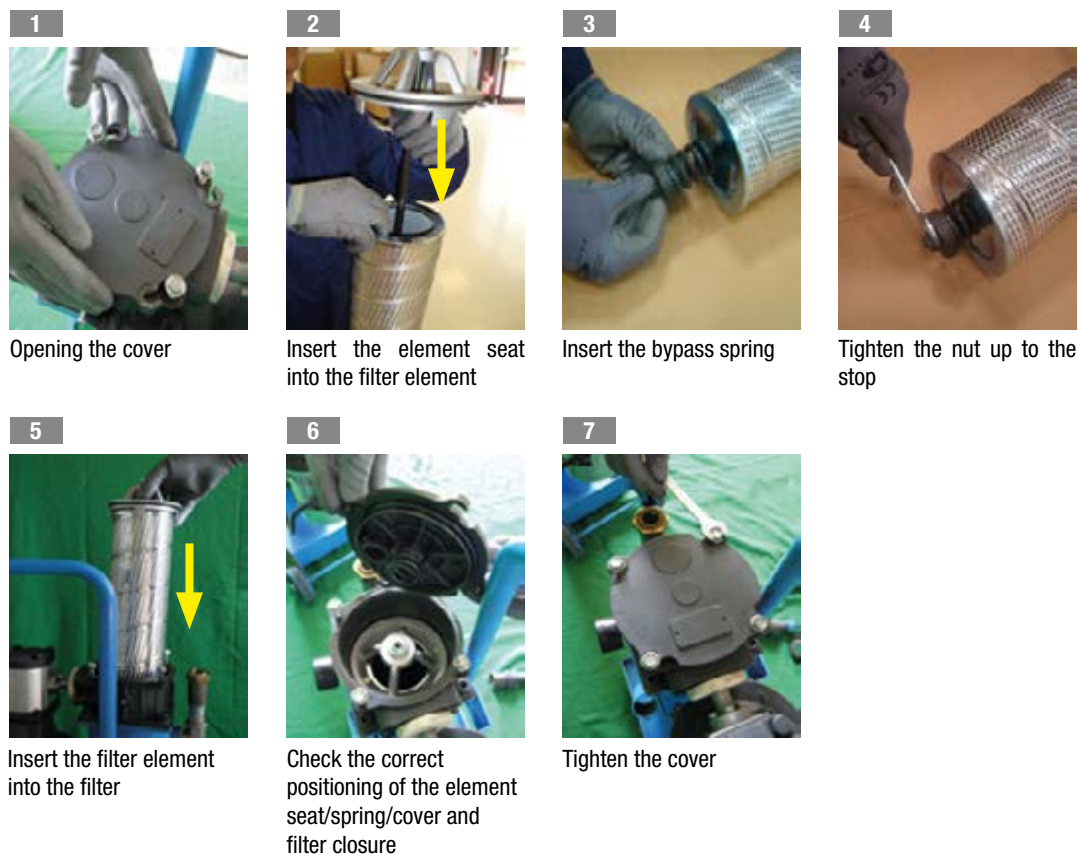

These operations must be performed with the machine off. Do not turn on the unit without first installing the filter element. Check that the filter element is inserted correctly.



CAUTION

We recommend using only original MP Filtri filter cartridges.



NOTE

# UFM041

## 6.3 Wiring diagram

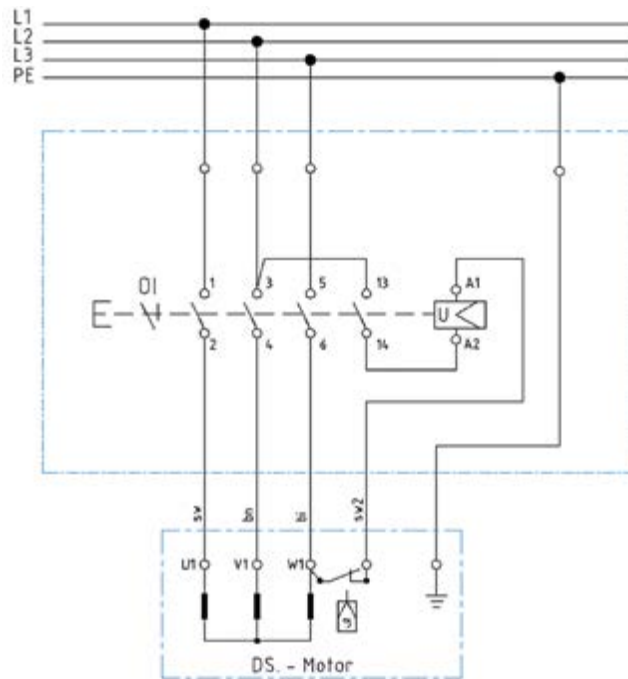

### 6.3.1 Electrical connection

The trolley must be connected via the plug supplied to the power supply, checking:

- the laws and technical specifications valid in the place and at the time of installation
- that the power supply voltage and the frequency at the connection point are compatible with those indicated on the rating plate of the mobile filtration unit
- the data shown on the rating plate.

It is recommended to use a multi-wire cable with a minimum cross-section of  $4 \times 2.5 \text{ mm}^2$  for the connection of the electric motor.

The red plug indicates a three-phase motor, the blue plug a single-phase motor.

The supply voltage must correspond to the voltage specified on the rating plate.

The construction features of the electric cable guarantee great flexibility, excellent resistance to weather conditions, oils and greases, mechanical and thermal stresses: Standard IMQ-CPT-007, CEI EN 50525-2-2.

Compliant with requirements of the BT 2006/95/CE directives.

The terminal box contains metal elements that are under hazardous voltage; after making the connections, always close the box cover.



NOTE

### 6.3.2 Triangular electrical connection of a three-phase motor

This motor is connected to the three-phase line, which can be 230 V or more commonly 400 V. Since the windings that make up the motor must be powered at 230 V, the connection must be made in the following manner:

- *Delta connection: this connection applies the same voltage to the windings as to the line.*

To be able to change the direction of rotation it is sufficient to invert two phases by acting directly on the appropriate five-pole CE plug (see photo on the right).



### 6.3.3 Electrical connection of a single-phase motor

Depending on its type, this motor is connected to the single-phase line in only one way:

- Motor with single-phase winding: Characteristic system for single-phase motors that have only a single winding, in which one end must be connected to the phase and the other end to the neutral conductor. To change the direction of rotation of the motor, reverse phase and neutral.
- Motor with two-phase winding: Two-phase winding that, as for a single-phase winding, functions with a permanently powered capacitor. To change the direction of rotation, connect the terminals as shown in the circuit diagram.

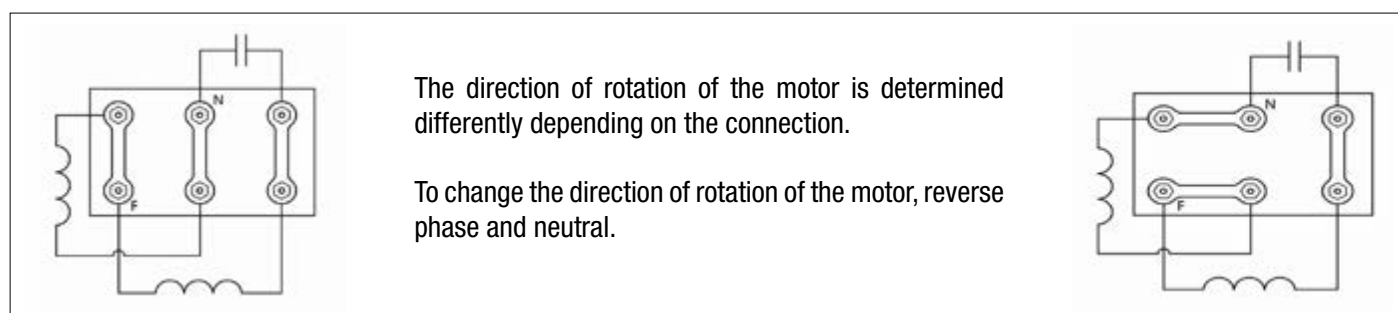

### 6.3.4 Electrical panel



3-phase electrical panel



Single-phase electrical panel

### 6.3.5 Electrical panel labels - not applicable for UFM041

## 6.4 Use

### 6.4.1 Installation

The mobile filtration unit must be positioned in a place that guarantees its stability during use.

#### TRANSFER

Connect/immerse the metal suction lance (IN) to the tank or to the drum, immerse the discharge hose (OUT) in the machine tank or in the drum which should be transferred to.

If the transfer oil is to be cleaned, it is advisable to filter the oil contained in the drum or tank several times before being transferred. In this case immerse the metal suction lances (IN) and the discharge lances (OUT) in the barrel or tank to be transferred to. Be careful that the lances remain below the level of the oil to be transferred in order to avoid foaming and cavitation; space the ends of the two lances in order to recirculate all the fluid and not generate an emulsion.

# UFM041

## FILTRATION

Immerse the metal lances for suction (IN) and for discharge (OUT) inside the tank far from each other, if possible positioning them at different heights (100 mm suction from the bottom of the tank, discharge immersed a minimum of 200 mm).

Make sure that the tubes/lances are properly fixed or perfectly stable before starting.  
Be careful not to mix up the suction and discharge hoses. The suction hose (IN) is the one with the largest diameter.

The discharge lance must in general have unrestricted flow. It is prohibited to install taps or components on both hoses that may obstruct or reduce the flow of the fluid.



### 6.4.2 Power on

Insert the electric plug into a socket.

Check the direction of rotation in the version with three-phase motor. **NOTE**

Three-phase electric power supply with protective conductor is required for the power supply of the trolley.



Electrical connection for the single-phase motor



Electrical connection for the three-phase motor (5 poles plug)



5 poles plug for the three-phase motor



Before starting up the electric motor, make sure that the suction lance (IN) is immersed in the fluid.



Operate the rotary knob for a few seconds and observe the direction of rotation. The direction observed on the fan side must be clockwise, otherwise the phases L1 and L2 must be inverted.

**NOTE**

After inserting the plug, turn the rotary knob for turning on and off to "I" on the terminal box of the motor (Fig. 1).  
At this point the transfer and filtration of the fluid begins.



Rotary knob ON/OFF Fig.1

### 6.4.3 Air vent - not applicable for UFM041

### 6.4.4 Oil analysis with particle counter - not applicable for UFM041

## 6.4.5 Shutdown



On/off knob

Fig.2

When the operations have been completed, turn off the electric pump by turning the shut-off knob to "0" on the terminal box of the electric motor (Fig. 2) and disconnect the electrical connection plug.

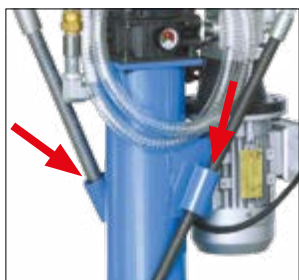

Lance holders

Fig.3

Put the lances in their respective housings (⚠ - Fig. 3), anchored to the frame paying attention to the fluid still present in the hoses. Rewind the power supply cable.

The UFM041 is equipped with a thermal protection device against electrical overloads, short circuits and overheating. If a "BLOCK" occurs, check the operating conditions (e.g. clogged filter, fluid conditions, motor overheating, etc.) and reset the thermal protection by pressing the appropriate button on the side of the motor terminal box.

With oil temperatures above 40/45 °C, give special caution to the handling of the metal lances/tubes and movement of the trolley. Avoid direct contact with hot oil, the mobile filtration unit and its installed components.



## 6.4.6 Operating limits and environmental limits

The trolley is designed to operate at a maximum pressure of 5 bar.

The electric motor is designed to operate according to the rating plate data.

For use in environments with very cold or very hot temperatures, refer to the technical data provided in Section 5.

## 6.5 Normal and scheduled maintenance

The UFM041 does not require particular maintenance interventions, it is in any case a good rule to check the perfect condition of the suction and discharge hoses before each use. Check that the filter element is correctly installed and that the filter cover is tightly screwed on.

Periodically check the tightness of the hydraulic connections and if the electrical cable ends in the motor terminal box are tight. Also check the cleanliness of the "Y" shaped filter for any accumulated macro impurities, so as to preserve the filter element (MR2504).

## 6.5.1 Oil leaks

Oil leaks can form on the joints of the hoses and on fittings if any connections or screws are loosened, in which case we recommend checking the correct tightness.

If the operations described above are not able to solve the problem, contact the manufacturer.

## 6.6 Filter clogging

The conditions relating to the clogging of the filter element are guaranteed by a pressure gauge (Fig. 4) mounted on the head of the MPH250 filter. When the pressure reaches 2.5 bar (fig. 4 green zone), replace the filter element and at the same time clean the "Y" shaped filter in the suction line.

The MPH filter is equipped with a bypass valve with a response pressure set at 3 bar (fig. 4 red zone).



Pressure gauge



Fig.4

It is recommended to never exceed the response pressure of the bypass valve (3 bar).

The filter element must always be replaced before the pressure gauge reaches the yellow zone (fig. 4).



### 6.6.1 Replacing the filter element

Before proceeding with the replacement of the filter element, make sure that the oil temperature is lower than +40/45 °C.

Replace the filter element whenever necessary, i.e. whenever the gauge indicates that the filter is clogged (1.75 bar) or when different fluids must be filtered.

The filtration of the filter element takes place from inside to outside, the residual oil in the filter body is normally clean. The oil must be emptied only when different fluids must be filtered using the drain valve (Fig. 5) installed at the base of the filter body.



Drain valve

Fig.5

It is recommended to clean the filter head thoroughly before replacing the filter element.

- 1**



Open the filter cover
- 2**



Remove the filter element
- 3**



Unscrew the bypass spring nut
- 4**



Remove the element seat
- 5**



Clean the filter element seat
- 6**



Check the correct positioning of the element seat/spring/cover and filter closure
- 7**



Insert the bypass spring
- 8**



Tighten the nut up to the stop
- 9**



Insert the filter element
- 10**



Check the correct positioning of the filter element
- 11**



Tighten the cover

Collect the replaced oil and filter element in a container and dispose of it in accordance with the regulations in force.



**NOTE**

Any intervention must be carried out with the machine off. Always remember to unplug the power supply.



**CAUTION**

## 6.6.2 Air vent - not applicable for UFM041

# UFM041

## 6.6.3 Replacing and cleaning of the filter in the suction line

Regularly (every 6 months or if you hear pump cavitation noises) check the blockage status of the suction filter and clean or replace it if necessary.

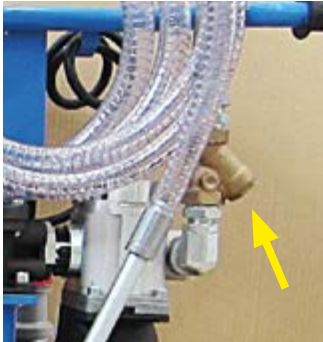

Suction filter

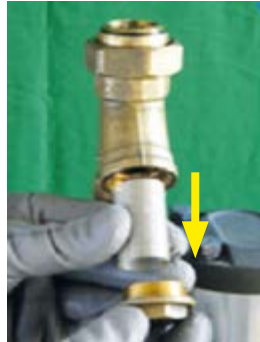

Unscrew the nut and remove the filter element

Collect the replaced oil and filter element in a container and dispose of it in accordance with the regulations in force.



NOTE

Any intervention must be carried out with the machine off. Always remember to unplug the power supply.



CAUTION

## 7. Designation & ordering code

### MOBILE FILTRATION UNIT UFM 041

Series	Configuration example:	UFM	041	T	A	1	0	1	0	P01
<b>UFM</b>										
<b>Size</b>										
<b>041</b>	34 l/min									
<b>Electric motor</b>										
<b>M</b>	230 V single phase									
<b>T</b>	400/230 V three phase									
<b>Seals</b>										
<b>A</b>	NBR									
<b>Pressure gauges and Clogging indicators (see below)</b>										
<b>1</b>	Manometer (*)									
<b>Filter element</b>										
<b>0</b>	Without element (for ordering, see below)									
<b>Filtration surface</b>										
<b>1</b>	Standard									
<b>Option</b>										
<b>0</b>	No options									
<b>Option</b>										
<b>P01</b>	MP Filtri standard									
<b>Pxx</b>	Customized									

Filtration element should be ordered separately

#### FILTRATION RATING

Inorganic microfibre		Wire mesh element	
<b>MR 250 4 A01 A P01</b>	01 µm	<b>MR 250 4 M25 A P01</b>	25 µm
<b>MR 250 4 A03 A P01</b>	03 µm	<b>MR 250 4 M60 A P01</b>	60 µm
<b>MR 250 4 A06 A P01</b>	06 µm		
<b>MR 250 4 A10 A P01</b>	10 µm		
<b>MR 250 4 A16 A P01</b>	16 µm		
<b>MR 250 4 A25 A P01</b>	25 µm		

#### WATER ABSORBER

Multi-Layer water absorber	
<b>MR 250 4 WA025 A P01</b>	25 µm

#### CLOGGING INDICATORS (\*)

**BVA** Axial pressure gauge

Settings	Ordering code
2.5 bar ±10%	BV A 25 P01

# UFM041

## 8. Spare parts

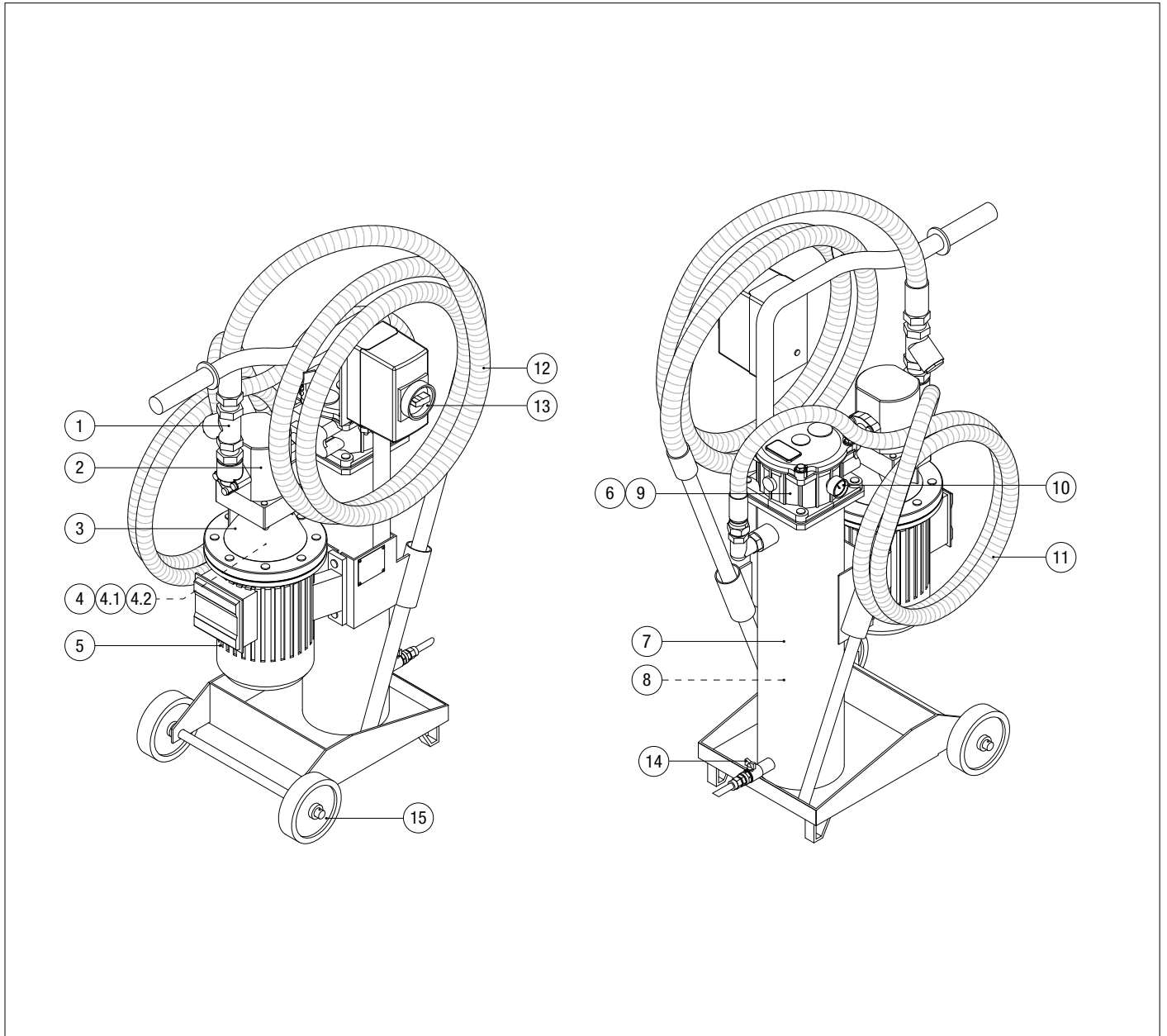

# UFM041

## 8.1 List of spare parts

Position	Series	Description	Code	Quantity
1	UFM041MA1010P01 UFM041TA1010P01	Y-shaped filter 1" BSP - 900 µm	02200007	1
2	UFM041MA1010P01 UFM041TA1010P01	External gear pump with integrated pressure relief valve	02200008	1
3	UFM041MA1010P01 UFM041TA1010P01	Pump bracket	LMG201MFS2004SANU	1
4	UFM041MA1010P01 UFM041TA1010P01	Pump side half-coupling	SGEA21FS200U	1
4.1	UFM041MA1010P01 UFM041TA1010P01	Motor side half-coupling	SGEA21M03044U	1
4.2	UFM041MA1010P01 UFM041TA1010P01	Elastic wheel	EGE2U	1
5	UFM041MA1010P01	Single-phase electric motor 0.75 kW 4P B3B5 IP55 2F 230V 50/60Hz CLASS IE3	02200010	1
	UFM041TA1010P01	3-phase electric motor 0.75 kW 4P B3B5 IP55 3F 230/400V 50/60Hz CLASS IE3	02200011	1
6	UFM041MA1010P01 UFM041TA1010P01	MPH250 filter head assembly	02019097	1
7	UFM041MA1010P01 UFM041TA1010P01	Return filter body	MPI2504FOAP03	1
8	UFM041MA1010P01 UFM041TA1010P01	Microfibre filter element 1 µm Microfibre filter element 3 µm Microfibre filter element 6 µm Microfibre filter element 10 µm Microfibre filter element 16 µm Microfibre filter element 25 µm Filter element in wire mesh 25 µm Filter element in wire mesh 60 µm Water absorber filter element	MR2504A01AP01 MR2504A03AP01 MR2504A06AP01 MR2504A010AP01 MR2504A016AP01 MR2504A025AP01 MR2504M25AP01 MR2504M60AP01 MR2504WA025AP01	1
9	UFM041MA1010P01 UFM041TA1010P01	Filter gasket kit MPH250	02050151	1
10	UFM041MA1010P01 UFM041TA1010P01	Pressure gauge	BVA25P01	1
11	UFM041MA1010P01 UFM041TA1010P01	Flexible suction hose DN25 L = 3000 mm Inclined cut nozzle Øe = 25 L = 700 mm	02200013	1
12	UFM041MA1010P01 UFM041TA1010P01	Flexible delivery hose DN20 L = 3000 mm Inclined cut nozzle Øe = 20 L = 700 mm	02200012	1
13	UFM041MA1010P01	Electrical panel single-phase version + cable and CEE plug	02200014	1
	UFM041TA1010P01	Electrical panel three-phase version + cable and CEE plug	02200015	1
14	UFM041MA1010P01 UFM041TA1010P01	Drain valve	02200039	1
15	UFM041MA1010P01 UFM041TA1010P01	Fixed wheel Ø125x30x15 mm. Blue polyurethane coating and black polyamide structure.	02200016	2

## 8.2 Filter element detail

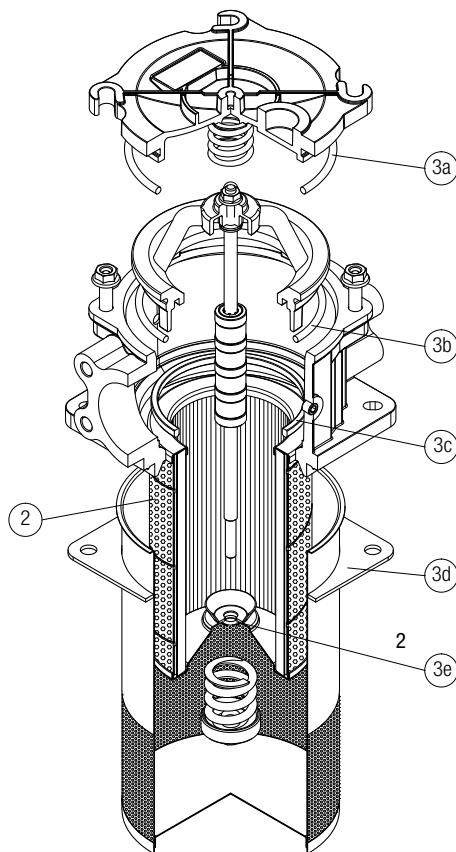

Item:	Q.ty: 1 pc. 2	Q.ty: 1 pc. 3 (3a ÷ 3e)	
Filter series	Filter element	Seal Kit code number	
		NBR	FPM
<b>MPH 250</b>	See spare parts (position 8)	02050151 (included with filter element)	02050152

All data, details and words contained in this publication are provided for use by technically qualified personnel at their discretion, without warranty of any kind.

MP Filtri reserves the right to make modifications to the models and versions of the described products at any time for both technical and/or commercial reasons.

For updated information please visit our website: [www.mpfiltri.com](http://www.mpfiltri.com)

The colors and the pictures of the products are purely indicative.

Any reproduction, partial or total, of this document is strictly forbidden.

All rights are strictly reserved



# WORLDWIDE NETWORK

CANADA ♦ CHINA ♦ FRANCE ♦ GERMANY ♦ INDIA ♦ SINGAPORE  
UNITED ARAB EMIRATES ♦ UNITED KINGDOM ♦ USA



PASSION  PERFORM

in @ y f



[mpfiltri.com](http://mpfiltri.com)  
Scan or click me!