

SGEG - SGEA - SGES - SGEK - EGE series

Flexible half-coupling in aluminium, cast iron and steel



Bell-Housings & Couplings sizing

	p.
AUTOMATIC	11
MANUALLY	12

SOFTWARE FOR AUTOMATIC CALCULATION

The web-based software program will allow you to select the most suitable MP Filtri's Filters, in accordance with your process design requirements.

The program will automatically check your input design process prior to propose you the acceptable solutions and create an output in PDF report style format.

The MP Filtri Selection Tool software program is easy to use with a flexible fast design method and provides improved layout formats with full descriptions.

The web-based tool is available at MP Filtri website at following link:
<https://www.mpfiltri.com/tools/>

The related, complete user guide is available as Manual and downloadable from the "Download" section of MP Filtri website, as well as scanning the following QR code



Scan or click me!



**BELL-HOUSINGS
& COUPLINGS**





BELL-HOUSINGS & COUPLINGS SIZING

A GUIDE TO SELECT THE CORRECT BELL-HOUSING AND DRIVE COUPLING MANUALLY

DATA REQUIRED

- Electric motor power/motor size
- Manufacturer and pump type

TO VERIFY:

- 1 - Pump and motor shaft dimensions (see electric motor data sheet)
- 2 - Shaft and flange pump (see pump data sheet)

Example:

- Electric motor 2.2 kW - size 100-112
- Atos pump code PFE31 - Shaft 1

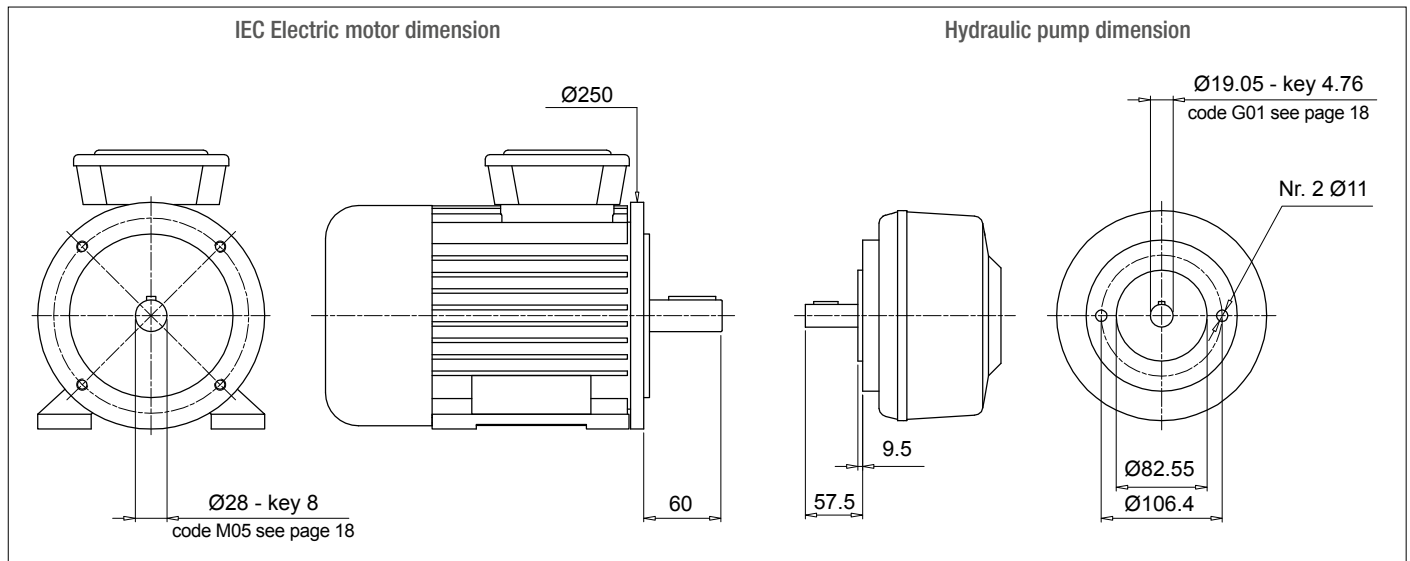

Bell-Housing's length calculation

- $H = 60 + 18 + 57.5 = 135.5$ mm (18 = Sp spider - see page 31)
- Choose type of bell-housing (LMC - LMS):
For monobloc bell-housing LMC/LDC series see pages 75 ÷ 81
For Low noise bell-housing LMS/LDS series see pages 81 ÷ 89
For Multi-components 2-3 bell housing series see pages 91 ÷ 111

Note:

The length of bell-housing must be \geq than the length calculated (135.5 mm)

Case A

Solution with monobloc bell-housing series **LMC/LDC**

Pages 75 ÷ 81 for IEC Electric motor size 100-112 - LMC250

LMC 250 bell-housing with height ≥ 135.5 - LMC250AFSQ

The bell-housing code must be completed with pump drilling code (see pages 60-61).

For the specific case:

Spigot hole 82.55 - PCD 106.4 - Nr.2 holes M10 : Drilling code 060

Definitive bell-housing code **LMC250AFSQ060**

Case B

Solution with low noise bell-housing series **LMS/LDS**

Pages 83 ÷ 89 for IEC Electric motor size 100-112 - LMS250

LMS 250 bell-housing with height ≥ 135.5 - LMS250AFSA

The bell-housing code must be completed with pump drilling code (see pages 60-61).

For the specific case:

Spigot hole 82.55 - PCD 106.4 - Nr.2 holes M10 : Drilling code 060

Definitive bell-housing code **LMS250AFSA060**

Coupling selection

Motor half-coupling (see page 26)

For IEC Electric motor size 100/112, the half-coupling is **SGEA21M05060**

Spider (see page 31)

For SGEA21, EGE2 - EGE2RR

(choose spider material on the base of the application, oil, temperature and cycle machine, etc.)

Pump half-coupling

Choose the drilling code - see pages 18-19 for shaft 19.05 - key 4.76 - code: **G01**

Pump half-coupling length = BH length - THK Spider - THK Spigot

$$\text{LMC} = 138 \text{ mm} - 60 - 18 - 9.5 = 50.5 \text{ mm}$$

$$\text{LMS} = 148 \text{ mm} - 60 - 18 - 9.5 = 60.5 \text{ mm}$$

LMC - Choose the half-coupling's length at page 26 \leq 50.5 mm.

LMS - Choose the half-coupling's length at page 26 \leq 60.5 mm.

LMC - Available length for SGEA21 = 50 mm

LMS - Available length for SGEA21 = 60 mm

Half coupling for LMC: **SGEA21G01050**

Half coupling for LMS: **SGEA21G01050**

Note: for multi pumps we recommend to use a specific support on the base of the pump's dimensions and weight.

The half-couplings series SGE*** allow secure transmission between the electric motor and the driven side; they are able to absorb shocks and vibration, in addition to compensating radial misalignment, angular and axial.

The assembly of the couplings can be horizontal/vertical, withstanding vibration and load reversals.

The complete range of couplings are extrapolated from the on-line software, with a length equal than the shaft on which must be mounted and they are completed with grub screw for fixing located on the key.

Available for cylindrical shaft with metric and imperial dimensions as well for splined shafts as per specification DIN, ISO and SAE.

Admissible misalignment radial, angular and axial

Max admissible radial misalignment

Half-coupling	R [mm]
SGE * 01	0.5
SGE * 21	1.0
SGE * 31	1.0
SGE * 40	1.0
SGE * 51	1.5
SGE * 60	1.5
SGE * 80	2.0
SGE * 90	2.0

Max admissible angular misalignment

Half-coupling	β [°]
SGE * 01	1.5°
SGE * 21	
SGE * 31	
SGE * 40	
SGE * 51	
SGE * 60	
SGE * 80	
SGE * 90	

Max admissible alignment

Half-coupling	A [mm]
SGE * 01	2.0
SGE * 21	2.5
SGE * 31	3.0
SGE * 40	3.5
SGE * 51	3.5
SGE * 60	3.5
SGE * 80	4.0
SGE * 90	5.0

Standard ATEX Directive 2014/34/EU and UK Regulation S.I. 2016 No. 1107 (as amended)



Half-couplings are available to use in hazardous area.

The couplings are certified according to Standard ATEX Directive 2014/34/EU and UK Regulation S.I. 2016 No. 1107 (as amended) - Category certified 2G - Area 1 and 2.

Other information available on our web site "www.mpfiltri.com".

MP Filtri couplings are developed with:

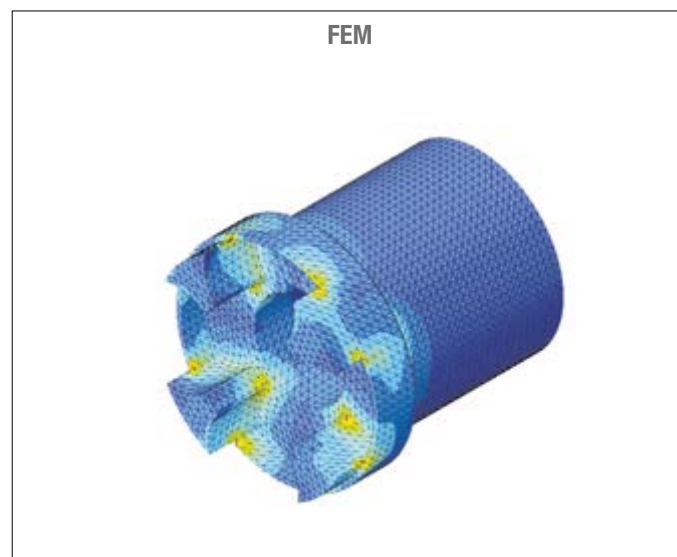

Drawings 3D available on website www.mpfiltri.com at section TOOLS.

Examples verification of the coupling

Torque transmitted by electric motor:

Mt: $9560 \times \text{kW} / \text{rpm} = \text{Nm}$

Me > $Mt \times S = \text{Nm}$

Where:

Mt: Torque transmitted by electric motor

Me: Torque transmitted by coupling

kW: Power of electric motor

Rpm: Revolutions per minute of electric motor

S: Service factor

Table 1

Small pumps, uniform load, low operating pressures e.g. rotary action machine tools - 5/8 work cycles per hour	1.3
Small pumps, uniform load, high working pressures e.g. lifting equipment - 120-150 work cycles per hour	1.5
Pumps, non-uniform load e.g. lifting equipment - 280-300 work cycles per hour	1.7

Example

Electric motor, 4 pole - 4 kW
hydraulic pump, uniform load, low operating pressure

Mt: $9560 \times 4 / 1500 = 25.45 \text{ Nm}$

Me > $25.49 \times 1.3 = 33 \text{ Nm}$

Half-coupling SGEA21 meets the above requirement.

Select the half-coupling of the calculated size from the motor half-couplings table.

Note: When selecting the coupling, remember that for pumps with splined shaft, only cast iron couplings of the SGEG series can be used.

Determine the size of the coupling according to the type of installation and application envisaged, on the basis of the formulas and the following tables:

Table 2

Half-coupling type	External diameter [mm]	Nominal torque Me - Nm	Maximum transmissible torque Me - Nm	
ROTAFIT				
SGEA01	SGEK01	44	10	20
SGEA21	SGEK21	70	95	190
SGEA31	SGEK31	85	190	380
SGEA51	SGEK51	109.5	310	620
ALUMINIUM				
SGEG01		40	10	20
SGEG30		80	190	380
SGEG40	SGEK40	95	310	620
SGEG60	SGEK60	120	430	860
SGEG80	SGEK80	160	1250	2500
SGEG90		200	5500	6100
CAST IRON				
SGES40		95	310	620
SGES60		120	430	860
SGES80		180	1250	2500
STEEL				

Nominal and maximum torque values are referred to couplings assembled with standard flexible spiders of the **EGE**** series (see page 31).

Where higher torques are to be transmitted, use flexible spiders of the **EGE**RR** series (see page 31).

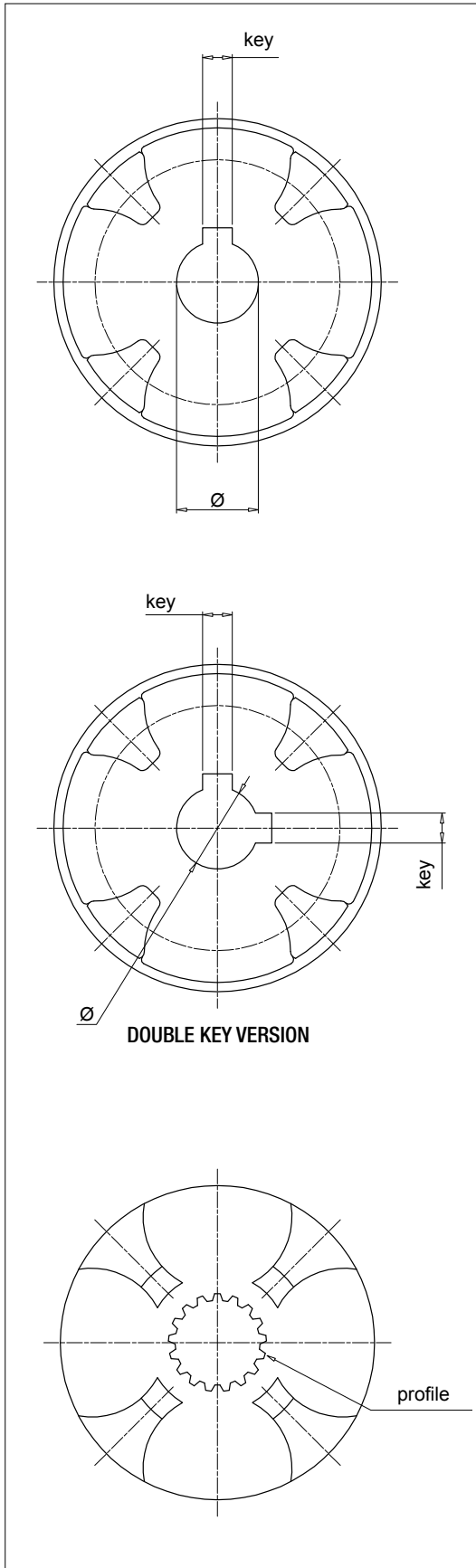

Parallel shaft - Metric Dimensions

Ø [mm]	key [mm]	Code
12	4	C00
15	5	C01
16	4	C02
16	5	C03
17	5	C04
18	6	C05
20	5	C06
19	5	C07
30	10	C08
20	6	C09
16	5	C10
15	4	C11
22	6	D00
24	6	D01
25	8	D02
30	8	D03
32	10	D04
35	10	D05
40	12	D06
45	14	D07
50	14	D08
70	20	D09
22	8	D10
52	16	D20
8	3	E00
10	3	E01
22	5	E02
32	8	E03
35	8	E04
82	22	E05
25	7	E06
63	18	E07
9	3	M00
11	4	M01
14	5	M02
19	6	M03
24	8	M04
28	8	M05
38	10	M06
42	12	M07
48	14	M08
55	16	M09
60	18	M10
65	18	M11
75	20	M12
80	22	M13
90	25	M14
95	25	M15
100	28	M16
110	28	M17
85	22	M18

Parallel shaft - Imperial Dimensions

Ø		key		Code
[inch]	[mm]	[inch]	[mm]	
7/16"	11.11	1/8"	3.18	G00
3/4"	19.05	3/16"	4.76	G01
7/8"	22.22	3/16"	4.76	G02
7/8"	22.22	1/4"	6.35	G03
1"	25.4	3/16"	4.76	G04
1"	25.40	1/4"	6.35	G05
1 1/4"	31.75	1/4"	6.35	G06
1 1/4"	31.75	5/16"	7.94	G07
1 3/8"	34.94	5/16"	7.94	G08
1 1/2"	38.1	3/8"	9.52	G09
1 5/8"	41.27	3/8"	9.52	H00
1 3/4"	44.45	7/16"	11.11	H01
2"	50.8	1/2"	12.7	H02
2 11/32"	53.94	1/2"	12.7	H03
3/4"	19.02	1/8"	3.17	H04
1"	25.4	3/16"	4.76	H05
5/8"	15.87	3/16"	4.76	H06
17/32"	13.45	1/8"	3.18	H07
11/16"	17.46	3/16"	4.76	H08
1/2"	12.7	1/8"	3.18	H09
5/8"	15.87	5/32"	3.97	L00
7/8"	22.22	5/32"	4	L01
11/8"	28.58	1/4"	6.35	L02
3/4"	19.05	1/4"	6.35	L03
1 7/8"	47.63	1/2"	12.7	L04
3 3/8"	85.73	7/8"	22.23	L05
2 3/8"	60.33	5/8"	15.88	L06
2 3/8"	60.33	1/2"	12.7	L07
2 7/8"	73.03	3/4"	19.05	L08
3 5/8"	92.07	7/8"	22.22	L09
1 5/8"	41.6	15/32"	12	L10
1 1/8"	28.58	5/16"	7.94	L15

Parallel shaft - Double Key

Ø [mm]	key [mm]	Code
16.00	4.00	C02***2H
	5.00	
20.00	5.00	C06***2M
	6.00	
19.00	5.00	C07***2L
	6.00	
24.00	6.00	D01***2N
	8.00	
30.00	8.00	D03***2P
	10.00	
22.22	4.76	G02***2E
	6.35	
25.40	6.35	G04***2F
	4.76	
31.75	6.35	G06***2G
	7.94	

*** = coupling length

SAE Bore - ANS.B.92.1-1970

Profile	Nr. of Th	Code
17 th 8/16	17	PD01
14 th 12/24	14	PD02
16 th 12/24	16	PD03
17 th 12/24	17	PD04
9 th 16/32	9	PD05
11 th 16/32	11	PD06
12 th 16/32	12	PD07
13 th 16/32	13	PD08
15 th 16/32	15	PD09
21 th 16/32	21	PD10
23 th 16/32	23	PD11
27 th 16/32	27	PD12
40 th 16/32	40	PD13
20 th 24/48	20	PD14
21 th 24/48	21	PD15
23 th 24/48	23	PD16
25 th 24/48	25	PD17
26 th 24/48	26	PD18
27 th 12/48	27	PD19
28 th 24/48	28	PD20
29 th 24/48	29	PD21
32 th 24/48	32	PD22
21 th 32/64	21	PD23
30 th 32/64	30	PD24
33 th 32/64	33	PD25
23 th 40/80	23	PD26
36 th 48/96	36	PD27
41 th 48/96	41	PD28
47 th 48/96	47	PD29
13 th 8/16	13	PD30
15 th 8/16	15	PD31
14 th 16/32	14	PD32
40 th 16/32	40	PD33
33 th 16/32	33	PD34
9 th 20/40	9	PD35
10 th 16/32	10	PD36
25 th 20/40	25	PD37

Splined bore as per standard DIN5480

Profile	Nr. of Th	Code
W18 x 1.25 x 13	13	PA01
W20 x 1.25 x 14	14	PA02
W25 x 1.25 x 18	18	PA03
W28 x 1.25 x 21	21	PA04
W32 x 1.25 x 24	24	PA05
W38 x 1.25 x 29	29	PA06
W30 x 2 x 14	14	PA07
W32 x 2 x 14	14	PA08
W35 x 2 x 16	16	PA09
W37 x 2 x 17	17	PA10
W38 x 2 x 18	18	PA11
W40 x 2 x 18	18	PA12
W42 x 2 x 20	20	PA13
W45 x 2 x 21	21	PA14
W50 x 2 x 24	24	PA15
W55 x 2 x 26	26	PA16
W60 x 2 x 28	28	PA17
W70 x 2 x 34	34	PA18
W80 x 2 x 38	38	PA19
W60 x 3 x 18	18	PA20
W70 x 3 x 22	22	PA21
W75 x 3 x 24	24	PA22
W90 x 3 x 28	28	PA23
W105 x 3 x 34	34	PA24
W80 x 3 x 25	25	PA25
W50 x 1.25 x 38	38	PA26
W62 x 1.25 x 48	48	PA27
W40 x 1.5 x 25	25	PA28
W32 x 1.5 x 20	20	PA29
W40 x 1.25 x 30	30	PA30

Splined bore as per standard DIN5481

Profile	Nr. of Th	Code
8 x 10	28	PC01
10 x 12	30	PC02
12 x 14	31	PC03
15 x 17	32	PC04
17 x 20	33	PC05
21 x 24	34	PC06
26 x 30	35	PC07
30 x 34	36	PC08
60 x 65	41	PC09

Splined bore as per standard DIN5482

Profile	Nr. of Th	Code
A15 x 12	8	PB01
A17 x 14	9	PB02
A18 x 15	10	PB03
A20 x 17	12	PB04
A22 x 19	13	PB05
A25 x 22	14	PB06
A28 x 25	15	PB07
A30 x 27	16	PB08
A32 x 28	17	PB09
A35 x 31	18	PB10
A38 x 34	19	PB11
A40 x 36	20	PB12
A42 x 38	21	PB13
A45 x 41	22	PB14
A48 x 44	23	PB15
A50 x 45	24	PB16
A52 x 47	25	PB17
A55 x 50	26	PB18
A58 x 53	27	PB19
A60 x 55	28	PB20
A62 x 57	29	PB21
A65 x 60	30	PB22
A68 x 62	31	PB23
A70 x 64	32	PB24
A72 x 66	33	PB25
A75 x 69	34	PB26
A78 x 72	35	PB27
A80 x 74	36	PB28
A82 x 76	37	PB29
A85 x 79	38	PB30
A88 x 82	39	PB31
A90 x 84	40	PB32
A92 x 86	41	PB33
A95 x 89	42	PB34
A98 x 92	43	PB35
A100 x 94	44	PB36

Technical data

Couplings - Flexible half-coupling in aluminium, cast iron and steel

Half-couplings materials

SGEA: Pressure die cast aluminium

SGEG: Cast Iron en-GJL-250 (gg25)

SGES: Steel C40

SGEK: Pressure die cast aluminium

SGEK: Cast Iron en-GJL-250 (gg25)



Spider materials

EGE** series: Oil-resistant NBR 85 Shore A - black colour

EGE**RR series: in polyurethane Laripur - 92 Shore A - LPR202-95A - red colour

Compatibility with fluids

- Mineral oils types HH-HL-HM-HR-HV, to ISO 6743/4 standard
- Water based emulsions types HFAE-HFAS, to ISO 6743/4 standard
- Water glycol type HFC, to ISO 6743/4 standard: ask for anodized version

Special Applications

Any applications not covered by the normal indications contained in this catalogue must be evaluated and approved by MP Filtri Technical and Sales Department

Temperature

Spider oil-resistant rubber: from -20 °C to +90 °C

Spider polyurethane resin: from -30 °C to +120 °C

Note

For temperatures outside this range, contact MP Filtri Technical and Sales Department



Range

IEC Electric Motors size	Aluminium		G25 UNI 5007 Cast Iron - C40 Carbon Steel			
	Shaft ISO 3019-2	Shaft ISO 3019-2	Shaft ANSI B92. 1A 1976	Shaft DIN 5480	Shaft DIN 5481	Shaft DIN 5482
IEC 80 Ø200 - Ø19x40	●	●	●	●	●	●
IEC 90 Ø200 - Ø24x50	●	●	●	●	●	●
IEC 100 Ø250 - Ø28x60	●	●	●	●	●	●
IEC 112 Ø250 - Ø28x60	●	●	●	●	●	●
IEC 132 Ø300 - Ø38x80	●	●	●	●	●	●
IEC 160 Ø350 - Ø42x110	●	●	●	●	●	●
IEC 180 Ø350 - Ø48x110	●	●	●	●	●	●
IEC 200 Ø400 - Ø55x110	●	●	●	●	●	●
IEC 225 Ø450 - Ø60x140		●	●	●	●	●
IEC 250 Ø550 - Ø65x140		●	●	●	●	●
IEC 280 Ø550 - Ø75x140		●	●	●	●	●
IEC 315 Ø660 - Ø80x170		●	●	●	●	●
IEC 355 Ø800 - Ø90x170		●	●	●	●	●

IEC Electric Motors size	European standard size						German standard size		
	0.5	1	2	3	3.5	4	ZB	ZF	ZG
IEC 63 Ø140 - Ø11x23	●	●	●				●		
IEC 71 Ø160 - Ø14x30	●	●	●				●		
IEC 80 Ø200 - Ø19x40	●	●	●	●			●	●	
IEC 90 Ø200 - Ø24x50	●	●	●	●			●	●	
IEC 110 Ø250 - Ø28x60		●	●	●	●		●	●	
IEC 112 Ø250 - Ø28x60		●	●	●	●		●	●	
IEC 132 Ø300 - Ø38x80		●	●	●	●	●		●	●
IEC 160 Ø350 - Ø42x110			●	●	●	●		●	●
IEC 180 Ø350 - Ø48x110			●	●	●	●		●	●
IEC 200 Ø400 - Ø55x110			●	●	●	●		●	●
IEC 225 Ø450 - Ø60x140				●	●	●			●

Couplings for standard IEC motors, protection class IP 54 / IP 55

A. C. motor 50 Hz			Motor output n=3000 RPM 2 poles		Coupling size	Motor output n=1500 RPM 4 poles		Coupling size	Motor output n=1000 RPM 6 poles		Coupling size	Motor output n=750 RPM 8 poles		Coupling size
Size	Shaft end Ø x L [mm]		Output P [kW]	Torque T [Nm]		Output P [kW]	Torque T [Nm]		Output P [kW]	Torque T [Nm]		Output P [kW]	Torque T [Nm]	
	2-pole	4, 6, 8 pole												
56	9 x 20		0.09	0.32		0.06	0.43		0.037	0.43				
			0.12	0.41		0.09	0.64		0.045	0.52				
63	11 x 23		0.18	0.62	01	0.12	0.88	01	0.06	0.7	01			01
			0.25	0.86		0.18	1.3		0.09	1.1				
71	14 x 30		0.37	1.3		0.25	1.8		0.18	2		0.09	1.4	
			0.55	1.9		0.37	2.5		0.25	2.8		0.12	1.8	
80	19 x 40		0.75	2.5		0.55	3.7		0.37	3.9		0.18	2.5	
			1.1	3.7		0.75	5.1		0.55	5.8		0.25	3.5	
90S	24 x 50		1.5	5	21	1.1	7.5	21	0.75	8	21	0.37	5.3	21
90L			2.2	7.4		1.5	10		1.1	12		0.55	7.9	
100L	28 x 60		3	9.8		2.2	15		1.5	15		0.75	11	
			3	20		1.5	15		1.1	16				
112M			4	13		4	27		2.2	22		1.5	21	
132S	38 x 80		5.5	18		5.5	36		3	30		2.2	30	
			7.5	25		7.5	49		4	40		3	40	
132M									5.5	55				
160M	42 x 110		11	36		11	72		7.5	75		4	54	
			15	49		15	98		11	109		5.5	74	
160L			18.5	60	40/51	15	98	40/51	11	109	40/51	7.5	100	40/51
180M	48 x 110		22	71		18.5	121							
180L			22	144		15	148		11	145				
200L	55 x 110		30	97		30	196		18.5	181		15	198	
			37	120		22	215							
200S	55 x 110	60 x 140			60	37	240	60			60	18.5	244	60
225M			45	145		45	292		30	293		22	290	
250M	60 x 140	65 x 140	55	177		55	356		37	361		30	392	
280S		75 x 140	75	241		75	484		45	438		37	483	
280M			90	289		90	581		55	535		45	587	
315S			110	353		110	707		75	727		55	712	
315M	65 x 140	80 x 170	132	423	80	132	849	80	90	873	80	75	971	80
			160	513		160	1030		110	1070		90	1170	
315L			200	641		200	1290		132	1280		110	1420	
			160	1550		132	1710							
315	85 x 170		250	802		250	1600		200	1930		160	2070	
			315	1010		315	2020		250	2410		200	2580	
355	75 x 140		355	1140		355	2280							
			400	1280		400	2570		315	3040		250	3220	
400	80 x 170	110 x 210	500	1600	90	500	3210	90	400	3850	90	315	4060	90
			560	1790		560	3580		450	4330		355	4570	
400			630	2020		630	4030		500	4810		400	5150	
			710	2270		710	4540		560	5390		450	5790	
			800	2560		800	5120		630	6060		500	6420	

SGEG-SGEA-SGES-SGEK

Designation & Ordering code

PUMP HALF-COUPLING FOR PARALLEL SHAFT

Pump half-coupling Configuration example: **SGE** **A** **21** **G02** **050** **2E**

SGE

Series and material

A Aluminium

G Cast Iron

S Steel

K Aluminium / Cast Iron - Reduced length 

Size	SGEG	SGEA	SGES	SGEK
	01	01	01	01
	30	21	30	21
	40	31	40	31
	60	51	60	51
	80		80	40
	90		90	60
				80

Pump shaft code

G02 See page 18

Length

050 See pages 26 ÷ 30

Double key way (available combinations only)

2E See page 18 (parallel shaft - double key)

PUMP HALF-COUPLING FOR SPLINED SHAFT

Pump half-coupling Configuration example: **SGE** **G** **40** **PD02** **050**

SGE

Series and material

G Cast Iron

S Steel

K Cast Iron - Reduced length 

Size	SGEG	SGES	SGEK
	01	01	01
	30	30	21
	40	40	31
	60	60	51
	80	80	40
	90	90	60
			80

Pump shaft code

PD02 See pages 19

Length

050 See pages 28 ÷ 30

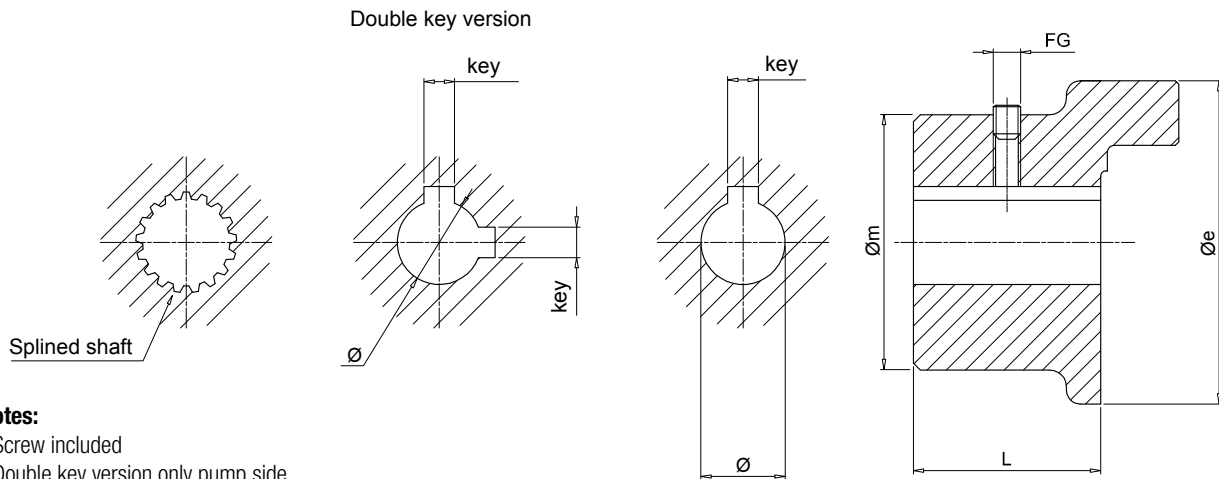

Notes:

- Screw included
- Double key version only pump side

Motor half-coupling

IEC - Electric motors		Half-coupling code	Dimensions [mm]							Weight [kg]
Motor size	Shaft end [Ø x L]		Øe	Øm	L	Ø	key	FG		
63	11x23	SGEG01M01021	40	50	21	11	4	M6	0.32	
71	14x30	SGEG01M02028	40	50	28	14	5	M6	0.42	
80	19x40	SGEG01M03040	40	50	40	19	6	M6	0.61	
90	24x50	SGEG01M04050	40	50	50	24	8	M6	0.77	
100 - 112	28x60	SGEG30M05060	80	65	60	28	8	M8	2.35	
		SGEG40M05060	95	75	60	28	8	M8	2.65	
132	38x80	SGEG30M06080	80	65	80	38	10	M8	3.15	
		SGEG40M06080	95	75	80	38	10	M8	3.55	
160	42x110	SGEG40M07110	95	75	110	42	12	M8	4.70	
180	48x110	SGEG40M08110	95	95	110	48	14	M8	4.55	
200	55x110	SGEG40M09110	95	95	110	55	16	M8	4.35	
		SGEG60M09110	120	98	110	55	16	M8	9.00	
225	60x140	SGEG60M10140	120	118	140	60	18	M8	12.30	
		SGEG60M11140	120	118	140	65	18	M8	12.00	
250	65x140	SGEG80M11140	160	138	140	65	18	M8	18.30	
		SGEG80M12140	160	138	140	75	20	M10	17.70	
280	75x140	SGEG90M12100	200	160	100	75	20	M10	21.00	
		SGEG80M13170	160	138	170	80	22	M10	20.60	
315	80x170	SGEG90M13100	200	160	100	80	22	M10	20.00	
		SGEG90M15100	200	160	100	95	25	M10	19.00	
400	100x210	SGEG90M16100	200	160	100	100	28	M10	18.00	

Pump half-couplings

Half-coupling code	Dimensions [mm]					Standard lengths [mm]
	Ø min	Ø max	Øe	L min	L max	
SGEG01 *** **	-	24	40	20	50	every 5 mm
SGEG30 *** **	-	42	80	30	80	
SGEG40 *** **	-	55	95	30	110	
SGEG60 *** **	-	75	120	40	140	
SGEG80 *** **	-	85	160	50	170	
SGEG90 *** **	-	100	200	40	100	

Complete the half-coupling code with the shaft's code and length

Example: **SGEG40PD02040**

PD02 - see page 19

040 - table "pump half-coupling - standard lengths"

All SGEG series half-couplings are supplied with a grub screw hole as standard, and with a grub screw **UNI 5929 DIN 916** fitted to the hub.

Note: For lengths other than those indicated in "Pump half-coupling" table, contact MP Filtri Technical and Sales Department.

Dimensions

Double key version

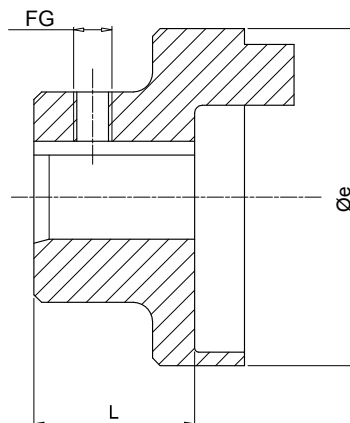
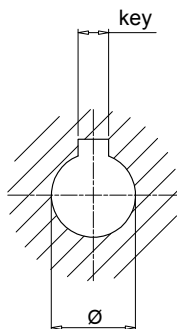
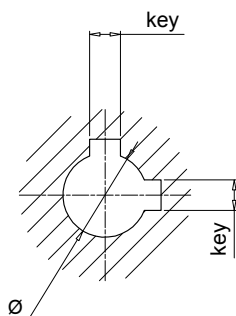

Notes:

- Screw not included
- Double key version pump side only

Motor half-coupling

IEC - Electric motors Motor size	Shaft end [Ø x L]	Half-coupling code	Øe	Dimensions [mm]				Weight [kg]
				L	Ø	key	FG	
63	11x23	SGEA01M01019	44.0	21	11	4	M5	0.07
71	14x30	SGEA01M02028	44.0	28	14	5	M5	0.08
80	19x40	SGEA01M03040	44.0	40	19	6	M5	0.12
		SGEA21M03040	70.0	40	19	6	M6	0.30
90	24x50	SGEA01M04048	44.0	48	24	8	M5	0.13
		SGEA21M04048	70.0	48	24	8	M6	0.28
100 - 112	28x60	SGEA21M05060	70.0	60	28	8	M6	0.33
		SGEA31M05060	85.0	60	28	8	M8	0.48
		SGEA21M06080	70.0	80	38	10	M6	0.44
132	38x80	SGEA31M06077	85.0	77	38	10	M8	0.78
		SGEA51M06077	109.5	77	38	10	M8	1.60
		SGEA51M07109	109.5	109	42	12	M8	1.60
160	42x110	SGEA51M07109	109.5	109	42	12	M8	1.60
180	48x110	SGEA51M08109	109.5	109	48	14	M8	1.60
200	55x110	SGEA51M09109	109.5	109	55	16	M8	1.90

Pump half-couplings

Half-coupling code	Dimensions [mm]					Standard lengths [mm]								FG		
	Ø min	Ø max	Øe	L min	L max	17	23	30	40	44	48	-	-		-	-
SGEA01 *** **	11	19	44.0	17	50	17	23	30	40	44	48	-	-	-	-	M5
SGEA21 *** **	15	24	70.0	23	50	35	40	42	44	48	50	-	-	-	-	M6
SGEA21 *** **	25	28	70.0	40	60	40	42	44	48	50	55	58	60	-	-	M6
SGEA31 *** **	18	32	85.0	40	60	42	45	48	50	52	55	58	60	-	-	M8
SGEA31 *** **	38	42	85.0	60	80	60	65	70	77	80	-	-	-	-	-	M8
SGEA51 *** **	18	40	109.5	40	70	42	45	48	50	52	55	58	60	65	70	M8
SGEA51 *** **	38	55	109.5	70	109	70	75	80	85	90	95	100	105	109	-	M8

Complete the half-coupling code with the shaft's code and length

Example: **SGEA51D02040**

D02 - see page 18

040 - table "pump half-coupling - standard lengths"

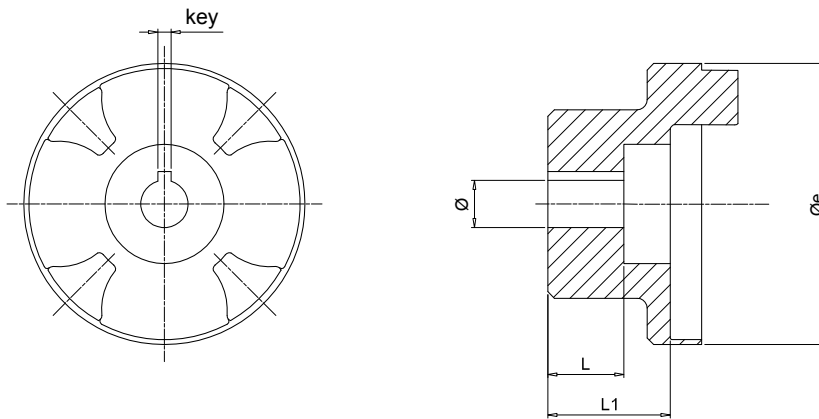

Half-coupling for gear pumps - parallel

Half-coupling code	Øe	Dimensions [mm]				key	Weight [kg]
		L	L1	Ø			
SGEA01FS05M	44	10.0	17.0	6	2	0.07	
SGEA01FS05C	44	10.0	17.0	7	2	0.08	
SGEA01FS1C0	44	-	17.0	12	3	0.13	
SGEA21FS1C0	70	14.5	21.5	12	3	0.48	
SGEA31FS1C0	85	14.5	37.0	12	3	1.90	

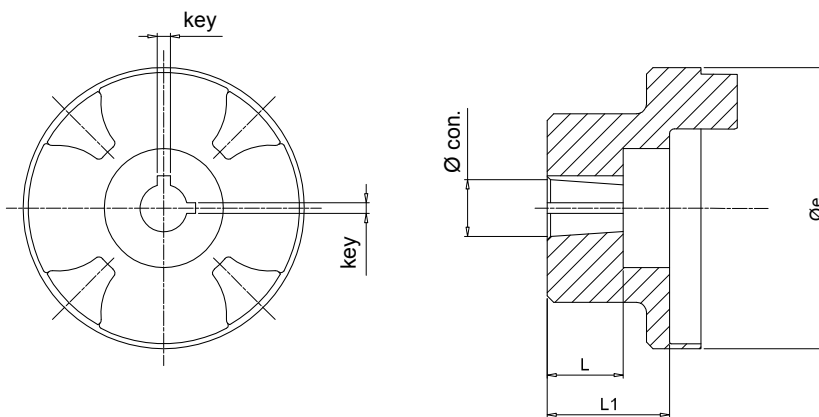

Half-coupling for gear pumps - tapered

Half-coupling code	Øe	Dimensions [mm]			key	Weight [kg]	Conical
		L	L1	Ø			
SGEA01FS100	44.0	14.5	16.0	9.7	2.4	0.12	1:8
SGEA01FS1M0	44.0	16.0	16.0	13.9	3	0.30	1:8
SGEA01FSZBR	44.0	11.5	14.5	9.8	2	0.28	1:5
SGEA21FS100	70.0	14.5	21.5	9.7	2.4	0.33	1:8
SGEA21FS1M0	70.0	18.5	21.5	13.9	3	0.78	1:8
SGEA21FS200	70.0	21.5	21.5	17.2	3.2 - 4	1.60	1:8
SGEA21FSZFR	70.0	20.0	21.5	16.9	3	1.60	1:5
SGEA21FS300	70.0	27.0	41.0	21.6	4	1.60	1:8
SGEA31FS100	85.0	14.5	37.0	9.7	2.4	1.90	1:8
SGEA31FS1M0	85.0	17.5	36.0	13.9	3	0.33	1:8
SGEA31FS200	85.0	23.0	37.0	17.2	3.2 - 4	0.48	1:8
SGEA31FS300	85.0	27.0	37.0	21.6	4	0.78	1:8
SGEA31FS350	85.0	35.0	37.0	25.6	4.76 - 5	1.60	1:8
SGEA31FSZFR	85.0	17.0	37.0	16.9	3	1.60	1:5
SGEA31FSZGR	85.0	27.0	34.0	25.2	5	1.60	1:5
SGEA51FS200	109.5	23.5	32.0	17.2	3.2 - 4	1.90	1:8
SGEA51FS300	109.5	25.0	32.0	21.6	4	1.90	1:8
SGEA51FS350	109.5	32.0	32.0	25.6	4.76 - 5	1.60	1:8
SGEA51FSZFR	109.5	19.5	32.0	16.9	3	1.90	1:5
SGEA51FSZGR	109.5	25.0	32.0	24.6	5	1.90	1:5

Dimensions

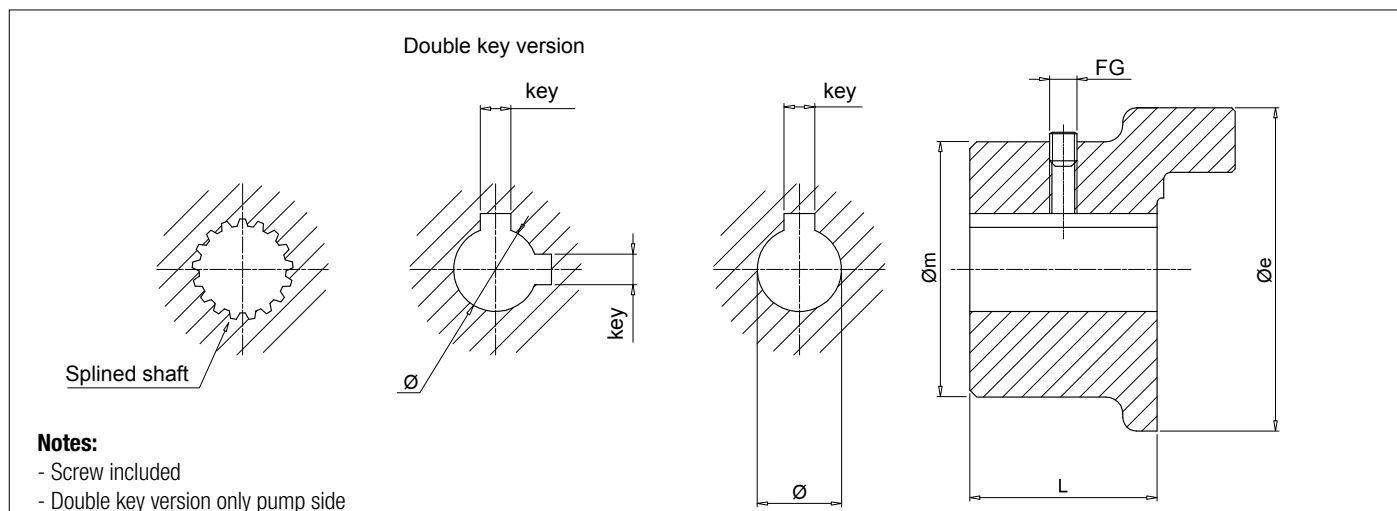

Notes:

- Screw included
- Double key version only pump side

Motor half-coupling

IEC - Electric motors		Half-coupling code	Dimensions [mm]							Weight [kg]
Motor size	Shaft end [Ø x L]		Øe	Øm	L	Ø	key	FG		
63	11x23	SGES01M01021	40	50	21	11	4	M6	0.32	
71	14x30	SGES01M02028	40	50	28	14	5	M6	0.42	
80	19x40	SGES01M03040	40	50	40	19	6	M6	0.61	
90	24x50	SGES01M04050	40	50	50	24	8	M6	0.77	
100 - 112	28x60	SGES31M05060	80	-	60	28	8	M8	2.35	
		SGES40M05060	95	-	60	28	8	M8	2.65	
132	38x80	SGES31M06080	80	-	80	38	10	M8	3.15	
		SGES40M06080	95	-	80	38	10	M8	3.55	
160	42x110	SGES40M07110	95	-	110	42	12	M8	4.70	
180	48x110	SGES40M08110	95	-	110	48	14	M8	4.55	
200	55x110	SGES40M09110	95	-	110	55	16	M8	4.35	
		SGES60M09110	120	-	110	55	16	M8	9.00	
225	60x140	SGES60M10140	120	-	140	60	18	M8	12.30	
250	65x140	SGES60M11140	120	-	140	65	18	M8	12.00	
		SGES80M11140	160	-	140	65	18	M8	18.30	
280	75x140	SGES80M12140	160	-	140	75	20	M10	17.70	
		SGES90M12100	200	-	100	75	20	M10	21.00	
315	80x170	SGES80M13170	160	-	170	80	22	M10	20.60	
		SGES90M13100	200	-	100	80	22	M10	20.00	
355	95x140	SGES90M15100	200	-	100	95	25	M10	19.00	
400	100x210	SGES90M16100	200	-	100	100	28	M10	18.00	

Pump half-couplings

Half-coupling code	Dimensions [mm]					Standard lengths [mm]
	Ø min	Ø max	Øe	L min	L max	
SGES01 *** **	-	24	40	20	50	every 5 mm
SGES30 *** **	-	42	80	30	80	
SGES40 *** **	-	55	95	30	110	
SGES60 *** **	-	75	120	40	140	
SGES80 *** **	-	85	160	50	170	
SGES90 *** **	-	100	200	40	100	

Complete the half-coupling code with the shaft's code and length

Example: **SGES40PD02040**

PD02 - see page 19

040 - table "pump half-coupling - standard lengths"

All SGES series half-couplings are supplied with a grub screw hole as standard, and with a grub screw **UNI 5929 DIN 916** fitted to the hub.

Note: For lengths other than those indicated in "Pump half-coupling" table, contact MP Filtri Technical and Sales Department.

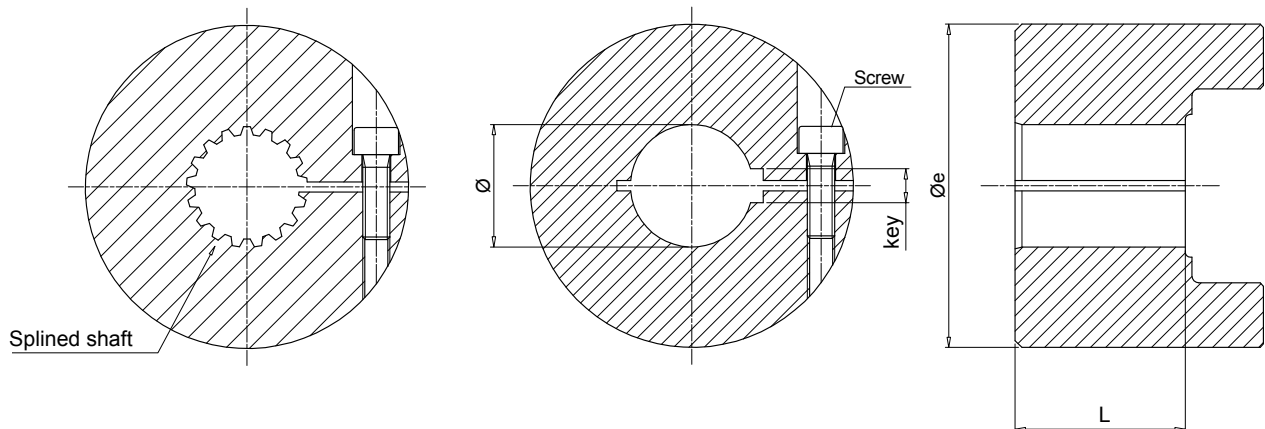

Motor half-coupling

IEC - Electric motors		Half-coupling code	Dimensions [mm]					Weight [kg]
Motor size	Shaft end [\emptyset x L]		$\emptyset e$	L	\emptyset	key	Screw	
132	38x80	SGES40M06050GO	95	50	38	10	M8	4.00
160	42x110	SGES40M07065GO	95	65	42	12	M8	5.00
180	48x110	SGES40M08065GO	95	65	48	14	M8	5.00
200	55x110	SGES60M09085GO	120	85	55	16	M10	8.00
225	60x140	SGES60M10085GO	120	85	60	18	M10	8.00
250	65x140	SGES60M11085GO	120	85	65	18	M10	8.00
280	75x140	SGES60M12085GO	120	85	75	20	M10	8.00
315	80x170	SGES80M13085GO	160	85	80	22	M10	13.00

Pump half-couplings

Half-coupling code	Dimensions [mm]			
	\emptyset min	\emptyset max	$\emptyset e$	L
SGES40 *** **	-	55	95	35
SGES60 *** **	-	65	120	65
SGES80 *** **	-	75	160	85

Complete the half-coupling designation with the pump interface code and the length.
 Example: **SGES40PD02035GO** (see page 19).

Dimensions

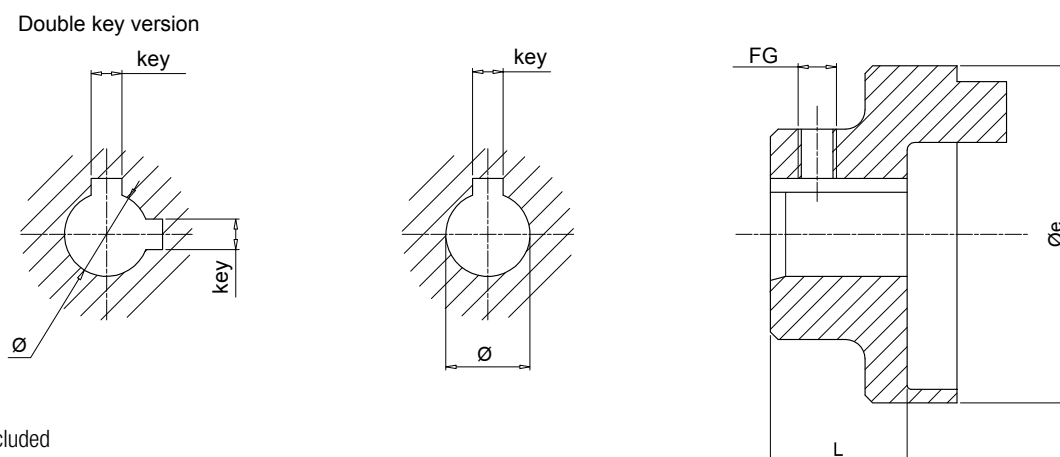

Notes:

- Screw not included
- Double key version pump side only

Motor half-coupling

IEC - Electric motors		Half-coupling code	Dimensions [mm]					Weight [kg]
Motor size	Shaft end [Ø x L]		Øe	L	Ø	key	FG	
63	11x23	SGEA01M01019	44.0	21	11	4	M5	0.07
71	14x30	SGEA01M02028	44.0	28	14	5	M5	0.08
80	19x40	SGEA01M03040	44.0	40	19	6	M5	0.12
		SGEA21M03040	70.0	40	19	6	M6	0.30
90	24x50	SGEA01M04048	44.0	48	24	8	M5	0.13
		SGEA21M04048	70.0	48	24	8	M6	0.28
100 - 112	28x60	SGEA21M05060	70.0	60	28	8	M6	0.33
		SGEA31M05060	85.0	60	28	8	M8	0.48
132	38x80	SGEA21M06080	70.0	80	38	10	M6	0.44
		SGEA31M06077	85.0	77	38	10	M8	0.78
		SGEA51M06077	109.5	77	38	10	M8	1.60
160	42x110	SGEA51M07109	109.5	109	42	12	M8	1.60
180	48x110	SGEA51M08109	109.5	109	48	14	M8	1.60
200	55x110	SGEA51M09109	109.5	109	55	16	M8	1.90

Pump half-couplings

Half-coupling code	Dimensions [mm]				FG	Weight [kg]
	Ø min	Ø max	Øe	L		
SGEK01 *** **	11	19	44.0	25	M5	0.08
SGEK21 *** **	15	28	70.0	35	M6	0.10
SGEK31 *** **	18	42	85.0	45	M8	0.15
SGEK51 *** **	18	55	109.5	50	M8	0.35

Complete the half-coupling code with the shaft's code and length

Example: **SGEK51D02050**

D02 - see page 18

050 - table "pump half coupling - dimension L"

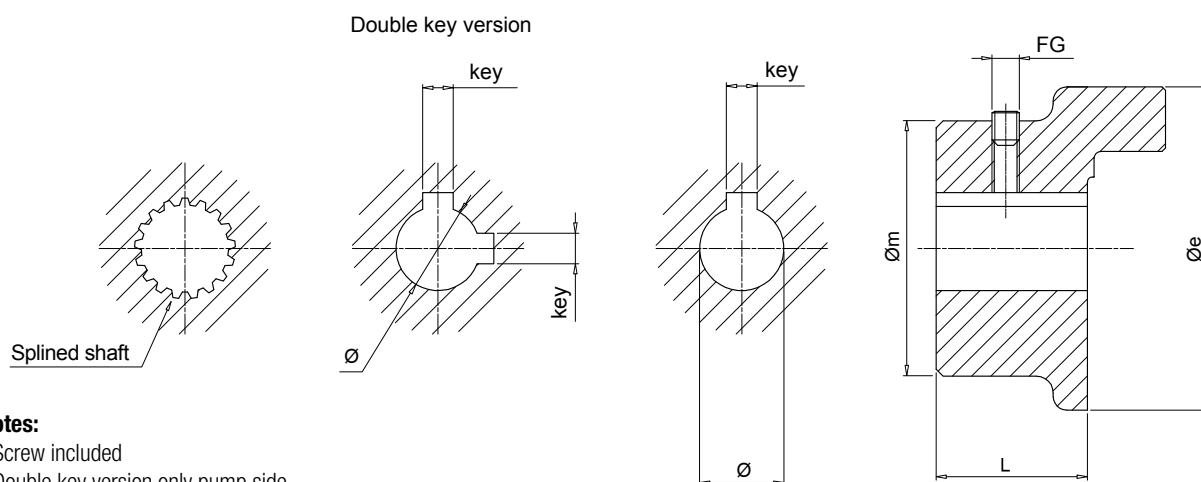
Notes:

- Screw included
- Double key version only pump side

Motor half-coupling

IEC - Electric motors		Half-coupling code	Dimensions [mm]							Weight [kg]
Motor size	Shaft end [Ø x L]		Øe	Øm	L	Ø	key	FG		
63	11x23	SGEG01M01021	40	50	21	11	4	M6	0.32	
71	14x30	SGEG01M02028	40	50	28	14	5	M6	0.42	
80	19x40	SGEG01M03040	40	50	40	19	6	M6	0.61	
90	24x50	SGEG01M04050	40	50	50	24	8	M6	0.77	
100 - 112	28x60	SGEG30M05060	80	65	60	28	8	M8	2.35	
		SGEG40M05060	95	75	60	28	8	M8	2.65	
132	38x80	SGEG30M06080	80	65	80	38	10	M8	3.15	
		SGEG40M06080	95	75	80	38	10	M8	3.55	
160	42x110	SGEG40M07110	95	75	110	42	12	M8	4.70	
180	48x110	SGEG40M08110	95	95	110	48	14	M8	4.55	
200	55x110	SGEG40M09110	95	95	110	55	16	M8	4.35	
		SGEG60M09110	120	98	110	55	16	M8	9.00	
225	60x140	SGEG60M10140	120	118	140	60	18	M8	12.30	
250	65x140	SGEG60M11140	120	118	140	65	18	M8	12.00	
		SGEG80M11140	160	138	140	65	18	M8	18.30	
280	75x140	SGEG80M12140	160	138	140	75	20	M10	17.70	
		SGEG90M12100	200	160	100	75	20	M10	21.00	
315	80x170	SGEG80M13170	160	138	170	80	22	M10	20.60	
		SGEG90M13100	200	160	100	80	22	M10	20.00	
355	95x140	SGEG90M15100	200	160	100	95	25	M10	19.00	
400	100x210	SGEG90M16100	200	160	100	100	28	M10	18.00	

Pump half-couplings

Half-coupling code	Dimensions [mm]				FG	Weight [kg]
	Ø min	Ø max	Øe	L		
SGEK40 *** **	-	55	95	50	M8	3
SGEK60 *** **	-	75	12	65	M8	6
SGEK80 *** **	-	85	160	85	M10	8

Complete the half-coupling code with the shaft's code and length

Example: **SGEK40PD02050**

PD02 - see page 19

050 - table "pump half coupling - dimension L"

All SGEK/SGEK series half-couplings are supplied with a grub screw hole as standard, and with a grub screw **UNI 5929 DIN 916** fitted to the hub.

Note: For lengths other than those indicated in "Pump half-coupling" table, contact MP Filtri Technical and Sales Department.

EGE Spiders

Dimensions

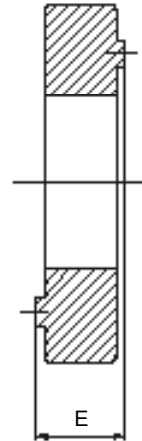
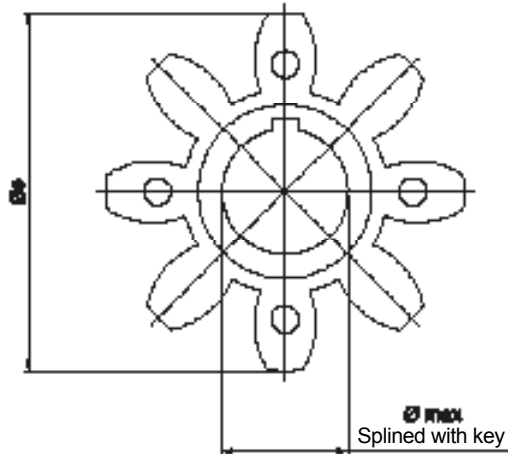

Notes:

Made of black oil-resistant rubber, these components serve to interconnect the two halves (motor - pump) of a flexible coupling.

EGE** series

Code	Half-coupling code		Dimensions [mm]			Nominal torque Nm	Max torque Nm	Weight [kg]
			E	Øe	Ø max			
		RCTAFIT						
EGE0	SGEA01 - SGEG01	SGEK01	15	40	16	10	20	0.006
EGE2	SGEA21	SGEK21	18	65	25	95	190	0.02
EGE3	SGEA31 - SGEG30	SGEK31	22	80	35	190	380	0.04
EGE5	SGEA51	SGEK51	26	105	45	310	620	0.06
EGE4	SGEG40 - SGES40	SGEK40	24	95	40	310	620	0.09
EGE6	SGEG60 - SGES60	SGEK60	28	120	55	430	860	0.13
EGE8	SGEG80 - SGES80	SGEK80	38	160	75	1250	2500	0.36

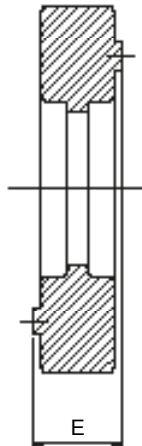
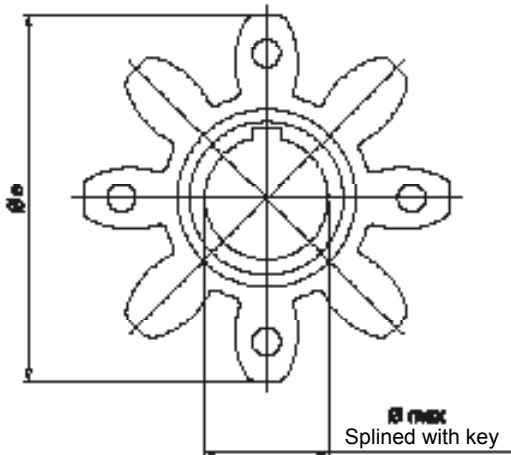

Notes:

Made in polyurethane Laripur - LPR202-95A, red colour, are suitable for applications where high levels of torque are transmitted.

EGE**RR series

Code	Half-coupling code		Dimensions [mm]			Nominal torque Nm	Max torque Nm	Weight [kg]
			E	Øe	Ø max			
		RCTAFIT						
EGE0RR	SGEA01 - SGEG01	SGEK01	15	40	16	15	30	0.006
EGE2RR	SGEA21	SGEK21	18	65	25	115	230	0.02
EGE3RR	SGEA31 - SGEG30	SGEK31	22	80	35	250	500	0.04
EGE5RR	SGEA51	SGEK51	26	105	45	400	800	0.06
EGE4RR	SGEG40 - SGES40	SGEK40	24	95	40	380	760	0.09
EGE6RR	SGEG60 - SGES60	SGEK60	28	120	55	550	1100	0.13
EGE8RR	SGEG80 - SGES80	SGEK80	38	160	75	1400	2900	0.36
EGE9RP	SGEG90	-	45	200	95	5500	6100	0.59

Version for extreme temperatures available on request.

For further information, contact MP Filtri Technical and Sales Department.

Metric cylindrical finish Keyway to DIN 6885 sheet 1

Size	Materials	Diameter / Key [mm]																								
		8	9	10	11	12	13	14	15	15	16	16	17	18	19	19	20	20	22	22	22	24	24	25	25	
		3	3	3	4	4	5	5	5	4	4	5	5	5	6	5	6	5	6	6	8	5	6	8	8	7
01	Aluminium				•	•	•	•	•	•	•	•	•	•	•	•	•	•	•	•	•	•	•	•		
	Steel				•	•	•	•	•	•	•	•	•	•	•	•	•	•	•	•	•	•	•	•		
	Cast Iron				•	•	•	•	•	•	•	•	•	•	•	•	•	•	•	•	•	•	•	•		
21	Aluminium							•	•	•	•	•	•	•	•	•	•	•	•	•	•	•	•	•	•	•
	Steel							•	•	•	•	•	•	•	•	•	•	•	•	•	•	•	•	•	•	•
	Cast Iron							•	•	•	•	•	•	•	•	•	•	•	•	•	•	•	•	•	•	•
31	Aluminium														•	•	•	•	•	•	•	•	•	•	•	•
	Steel														•	•	•	•	•	•	•	•	•	•	•	•
	Cast Iron														•	•	•	•	•	•	•	•	•	•	•	•
40	Aluminium																									
	Steel				•	•	•	•	•	•	•	•	•	•	•	•	•	•	•	•	•	•	•	•	•	•
	Cast Iron				•	•	•	•	•	•	•	•	•	•	•	•	•	•	•	•	•	•	•	•	•	•
51	Aluminium														•	•	•	•	•	•	•	•	•	•	•	•
	Steel														•	•	•	•	•	•	•	•	•	•	•	•
	Cast Iron														•	•	•	•	•	•	•	•	•	•	•	•
60	Aluminium																									
	Steel														•	•	•	•	•	•	•	•	•	•	•	•
	Cast Iron														•	•	•	•	•	•	•	•	•	•	•	•
80	Aluminium																									
	Steel														•	•	•	•	•	•	•	•	•	•	•	•
	Cast Iron														•	•	•	•	•	•	•	•	•	•	•	•
90	Aluminium																									
	Steel														•	•	•	•	•	•	•	•	•	•	•	•
	Cast Iron														•	•	•	•	•	•	•	•	•	•	•	•

Size	Materials	Diameter / Key [mm]																								
		28	30	30	32	32	35	35	38	40	42	45	48	50	52	55	60	63	65	70	75	80	82	90	95	100
		8	10	8	10	8	10	8	10	12	12	14	14	14	16	16	18	18	18	20	20	22	22	25	25	28
01	Aluminium																									
	Steel																									
	Cast Iron																									
21	Aluminium	•																								
	Steel	•																								
	Cast Iron																									
31	Aluminium	•	•	•	•	•	•	•	•																	
	Steel	•	•	•	•	•	•	•	•																	
	Cast Iron	•	•	•	•	•	•	•	•																	
40	Aluminium																									
	Steel	•	•	•	•	•	•	•	•	•	•	•	•													
	Cast Iron	•	•	•	•	•	•	•	•	•	•	•	•													
51	Aluminium	•	•	•	•	•	•	•	•	•	•	•	•	•	•	•										
	Steel																									
	Cast Iron																									
60	Aluminium																									
	Steel	•	•	•	•	•	•	•	•	•	•	•	•	•	•	•	•	•	•	•	•	•	•	•	•	•
	Cast Iron	•	•	•	•	•	•	•	•	•	•	•	•	•	•	•	•	•	•	•	•	•	•	•	•	•
80	Aluminium																									
	Steel	•	•	•	•	•	•	•	•	•	•	•	•	•	•	•	•	•	•	•	•	•	•	•	•	•
	Cast Iron	•	•	•	•	•	•	•	•	•	•	•	•	•	•	•	•	•	•	•	•	•	•	•	•	•
90	Aluminium																									
	Steel	•	•	•	•	•	•	•	•	•	•	•	•	•	•	•	•	•	•	•	•	•	•	•	•	•
	Cast Iron	•	•	•	•	•	•	•	•	•	•	•	•	•	•	•	•	•	•	•	•	•	•	•	•	•

Imperial cylindrical finish Keyway to DIN 6885 sheet 1

Size	Materials	Diameter / Key [mm]															
		11.11 3.18	12.7 3.18	13.45 3.18	15.87 4.76	15.87 3.97	17.46 4.76	19.02 3.17	19.05 4.76	19.05 6.35	22.22 4.76	22.22 6.35	22.22 4	25.4 6.35	25.4 4.76	26.94 4.76	28.58 6.35
01	Aluminium				•	•	•	•	•	•	•	•	•	•	•	•	•
	Steel				•	•	•	•	•	•	•	•	•	•	•	•	•
	Cast Iron				•	•	•	•	•	•	•	•	•	•	•	•	•
21	Aluminium							•	•	•	•	•	•	•	•	•	
	Steel							•	•	•	•	•	•	•	•	•	
	Cast Iron							•	•	•	•	•	•	•	•	•	
31	Aluminium							•	•	•	•	•	•	•	•	•	
	Steel							•	•	•	•	•	•	•	•	•	
	Cast Iron							•	•	•	•	•	•	•	•	•	
40	Aluminium																
	Steel				•	•	•	•	•	•	•	•	•	•	•	•	
	Cast Iron				•	•	•	•	•	•	•	•	•	•	•	•	
51	Aluminium							•	•	•	•	•	•	•	•	•	
	Steel							•	•	•	•	•	•	•	•	•	
	Cast Iron							•	•	•	•	•	•	•	•	•	
60	Aluminium																
	Steel							•	•	•	•	•	•	•	•	•	
	Cast Iron							•	•	•	•	•	•	•	•	•	
80	Aluminium																
	Steel							•	•	•	•	•	•	•	•	•	
	Cast Iron							•	•	•	•	•	•	•	•	•	
90	Aluminium																
	Steel												•	•	•	•	
	Cast Iron												•	•	•	•	

Size	Materials	Diameter / Key [mm]															
		28.58 7.94	31.75 6.35	31.75 7.94	34.94 7.94	38.1 9.52	41.27 9.52	41.6 12	44.45 11.11	47.63 12.7	50.8 12.7	53.94 12.7	60.33 15.88	60.33 12.7	73.03 19.05	85.73 22.23	92.07 22.22
01	Aluminium	•															
	Steel	•															
	Cast Iron	•															
21	Aluminium	•															
	Steel	•															
	Cast Iron	•															
31	Aluminium	•	•	•	•	•	•	•	•								
	Steel	•	•	•	•	•	•	•	•								
	Cast Iron	•	•	•	•	•	•	•	•								
40	Aluminium																
	Steel	•	•	•	•	•	•	•	•	•	•	•					
	Cast Iron	•	•	•	•	•	•	•	•	•	•	•					
51	Aluminium	•	•	•	•	•	•	•	•	•	•	•	•	•			
	Steel																
	Cast Iron																
60	Aluminium																
	Steel	•	•	•	•	•	•	•	•	•	•	•	•	•	•	•	•
	Cast Iron	•	•	•	•	•	•	•	•	•	•	•	•	•	•	•	•
80	Aluminium																
	Steel	•	•	•	•	•	•	•	•	•	•	•	•	•	•	•	•
	Cast Iron	•	•	•	•	•	•	•	•	•	•	•	•	•	•	•	•
90	Aluminium																
	Steel	•	•	•	•	•	•	•	•	•	•	•	•	•	•	•	•
	Cast Iron	•	•	•	•	•	•	•	•	•	•	•	•	•	•	•	•

SAE involute spline (angle 30°) - ANS.B.92.1.1970

Size	Materials	Nr. of th - Diametral pitch															
		9 16/32	10 16/32	11 16/32	12 16/32	13 16/32	14 16/32	15 16/32	21 16/32	23 16/32	27 16/32	33 16/32	40 16/33	14 12/24	16 12/24	17 12/24	13 8/16
01	Steel	•	•	•	•	•	•	•						•			
	Cast Iron	•	•	•	•	•	•	•						•			
21	Steel	•	•	•	•	•	•	•						•			
	Cast Iron	•	•	•	•	•	•	•						•			
31	Steel	•	•	•	•	•	•	•	•	•	•			•	•	•	•
	Cast Iron	•	•	•	•	•	•	•	•	•	•			•	•	•	•
40	Steel			•	•	•	•	•	•	•	•	•		•	•	•	•
	Cast Iron			•	•	•	•	•	•	•	•	•		•	•	•	•
60	Steel					•	•	•	•	•	•	•		•	•	•	•
	Cast Iron					•	•	•	•	•	•	•		•	•	•	•
80	Steel								•	•	•	•	•		•	•	•
	Cast Iron								•	•	•	•	•		•	•	•
90	Steel								•	•	•	•	•		•	•	•
	Cast Iron								•	•	•	•	•		•	•	•

Size	Materials	Nr. of th - Diametral pitch														
		15 8/16	17 8/16	20 24/48	21 24/48	23 24/48	25 24/48	26 24/48	28 24/48	29 24/48	32 24/48	23 40/80	36 48/96	41 48/96	47 48/96	33 32/64
01	Steel			•	•	•			•	•		•	•	•	•	
	Cast Iron			•	•	•			•	•		•	•	•	•	
21	Steel			•	•	•	•	•	•	•		•	•	•	•	
	Cast Iron			•	•	•	•	•	•	•		•	•	•	•	
31	Steel	•		•	•	•	•	•	•	•	•	•	•	•	•	
	Cast Iron	•		•	•	•	•	•	•	•	•	•	•	•	•	•
40	Steel	•	•	•	•	•	•	•	•	•	•	•	•	•	•	•
	Cast Iron	•	•	•	•	•	•	•	•	•	•	•	•	•	•	•
60	Steel	•	•	•	•	•	•	•	•	•	•			•	•	•
	Cast Iron	•	•	•	•	•	•	•	•	•	•			•	•	•
80	Steel	•	•								•					•
	Cast Iron	•	•								•					•
90	Steel	•	•								•					•
	Cast Iron	•	•								•					•

Spline bores to DIN 5480

Size	Materials	Nr. of th - Size										
		13 18x1.25	14 20x1.25	14 30x2	14 32x2	16 35x2	17 37x2	18 25x1.25	18 38x2	18 40x2	20 42x2	18 60x3
01	Steel	•	•									
	Cast Iron	•	•									
21	Steel	•	•	•	•	•		•				
	Cast Iron	•	•	•	•	•		•				
31	Steel	•	•	•	•	•	•	•				
	Cast Iron	•	•	•	•	•	•	•				
40	Steel	•	•	•	•	•	•	•	•	•	•	
	Cast Iron	•	•	•	•	•	•	•	•	•	•	
60	Steel	•	•	•	•	•	•	•	•	•	•	•
	Cast Iron	•	•	•	•	•	•	•	•	•	•	•
80	Steel				•	•	•		•	•	•	•
	Cast Iron				•	•	•		•	•	•	•
90	Steel								•	•	•	•
	Cast Iron								•	•	•	•

Size	Materials	Nr. of th - Size									
		21 28x1.25	21 45x2	22 70x3	24 32x1.25	24 50x2	26 55x2	28 60x2	29 38x1.25	34 70x2	38 80x2
01	Steel										
	Cast Iron										
21	Steel	•									
	Cast Iron	•									
31	Steel	•			•				•		
	Cast Iron	•			•				•		
40	Steel	•	•		•				•		
	Cast Iron	•	•		•				•		
60	Steel	•	•		•	•	•	•	•		
	Cast Iron	•	•		•	•	•	•	•		
80	Steel		•	•	•	•	•	•	•	•	•
	Cast Iron		•	•	•	•	•	•	•	•	•
90	Steel		•	•		•	•	•	•	•	•
	Cast Iron		•	•		•	•	•	•	•	•

Spline bores to DIN 5481

Size	Materials	Nr. of th - Size									
		28 8x10	30 10x12	31 12x14	32 15x17	33 17x20	34 21x24	35 26x30	36 38x34	41 60x65	
01	Steel	•	•	•	•	•	•				
	Cast Iron	•	•	•	•	•	•				
21	Steel	•	•	•	•	•	•	•			
	Cast Iron	•	•	•	•	•	•	•			
31	Steel			•	•	•	•	•	•		
	Cast Iron			•	•	•	•	•	•		
40	Steel							•	•	•	
	Cast Iron							•	•	•	
60	Steel								•	•	•
	Cast Iron								•	•	•
80	Steel										•
	Cast Iron										•
90	Steel										•
	Cast Iron										•

Spline bores to DIN 5482

Size	Materials	Nr. of th - Size															
		8 A15x12	9 A17x14	10 A18x15	12 A20x17	13 A22x19	14 A25x22	15 A28x25	16 A30x27	17 A32x28	18 A35x31	19 A38x34	20 A40x36	21 A42x38	22 A45x41	23 A48x44	24 A50x45
01	Steel	•	•	•	•	•	•										
	Cast Iron	•	•	•	•	•	•										
21	Steel	•	•	•	•	•	•	•	•	•	•						
	Cast Iron	•	•	•	•	•	•	•	•	•	•						
31	Steel							•	•	•	•	•					
	Cast Iron							•	•	•	•	•					
40	Steel																
	Cast Iron																
60	Steel																
	Cast Iron																
80	Steel																
	Cast Iron																
90	Steel																
	Cast Iron																

Size	Materials	Nr. of th - Size														
		25 A52x47	26 A55x50	27 A58x53	28 A60x55	29 A62x57	30 A65x60	31 A68x62	32 A70x64	33 A72x66	34 A75x69	35 A78x72	36 A80x74	37 A82x76	38 A85x79	39 A88x82
01	Steel															
	Cast Iron															
21	Steel															
	Cast Iron															
31	Steel															
	Cast Iron															
40	Steel	•	•													
	Cast Iron	•	•													
60	Steel	•	•	•	•	•	•	•								
	Cast Iron	•	•	•	•	•	•	•								
80	Steel	•	•	•	•	•	•	•	•	•	•	•	•	•	•	•
	Cast Iron	•	•	•	•	•	•	•	•	•	•	•	•	•	•	•
90	Steel	•	•	•	•	•	•	•	•	•	•	•	•	•	•	•
	Cast Iron	•	•	•	•	•	•	•	•	•	•	•	•	•	•	•