

SFMC 250 series

Flow rate up to 160 l/min



SFMC 250 GENERAL INFORMATION

Description

Technical data

Suction filters

Flow rate up to 160 l/min

SFMC 250 is a range of suction filters with integrated shut-off valve for protection of the downstream pump against the coarse contamination.

They are placed below the minimum oil level, directly connected to the suction line of the pump.

They can be fitted on the side or below the tank, allowing a more flexible design of the tank.

The shut-off valve closes automatically when the cover is removed, allowing the filter element replacement without the fluid drop.

Available features:

- Female threaded connections up to 1" and flanged connections up to 1 1/2", for a maximum flow rate of 160 l/min
- Multiple connections, to connect several suction lines
- Bypass valve, to relieve excessive pressure drop across the filter media
- Magnetic filter, to hold the ferrous particles
- Visual, electrical and electronic clogging indicators

Common application:

- Mobile machines
- Industrial equipment

Filter housing materials

- Filter body: Aluminium
- Cover: Polyamide, GF reinforced
- Valve: Polyamide, GF reinforced - Steel
- Anti-Emptying valve: Steel

Bypass valve

Opening pressure 0.03 MPa (0.3 bar) ±10%

Filter element features

Filter SFMC	Filter element SMC		
Δp Element type			
Element media	Construction	Δp Series	Δp
M - Wire mesh	Standard	A	1 bar
P - Paper	Standard	A	1 bar
<i>Please see ordering code tables to check element Δp series availability based on filter features.</i>			
Flow direction through the filter element:			
From IN to OUT			

Seals

- Standard NBR series A or W
- Optional FPM series V or Z

Temperature

From -25 °C to +110 °C

Note

SFMC 250 filters mounting, see the drawings on page 50 and following.

Weights [kg] and volumes [dm³]

Filter series	Weights [kg]	Volumes [dm ³]
SFMC 250	2.8	2.3
SFMC 250	2.8	2.4

Flow rates [l/min]

Filter series	Filter element design - N Series					
	M0025	M0060	M0090	M0250	P0010	P0025
SFMC 250	147	151	155	160	85	132

Maximum flow rate for a complete suction filter with a pressure drop $\Delta p = 0.08$ bar.

The reference fluid has a kinematic viscosity of 30 mm²/s (cSt) and a density of 0.86 kg/dm³.

For different pressure drop or fluid viscosity we recommend to use our selection software available on www.mpfiltri.com.

You can also calculate the right size using the formulas present on the FILTER SIZING paragraph at the beginning of the full catalogue or at the beginning of the filter family brochure. Please, contact our Sales Department for further additional information.

Hydraulic diagram

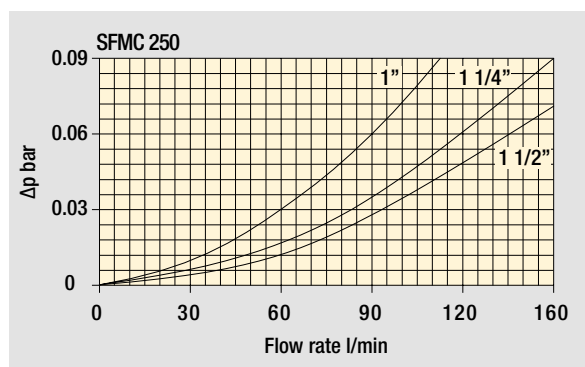
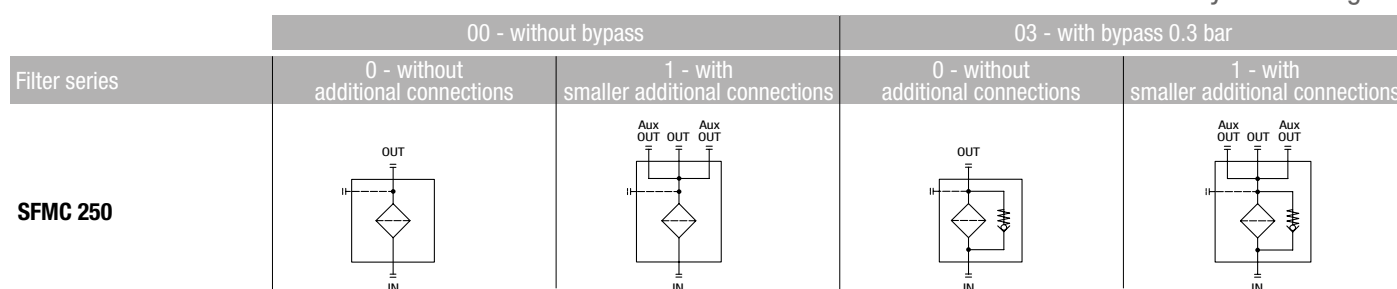

Pressure drop

Filter housings
 Δp pressure drop

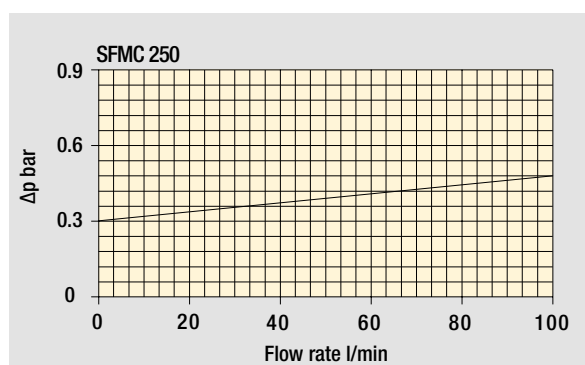

Bypass valve
pressure drop

The curves are plotted using mineral oil with density of 0.86 kg/dm³ in compliance with ISO 3968. Δp varies proportionally with density.

SFMC 250

Designation & Ordering code

COMPLETE FILTER

Series	Example 1:	SFMC	250	10	M0025	A	A	00	FF112	0	5T	MA	P01	NN
SFMC	Example 2:	SFMC	250	10	P0010	A	V	00	FG112	0	5T	NN	P01	NN

Size
250

Length
10

Filtration rating (filter media)	
M0025 Wire mesh 25 µm	P0010 Resin-impregnated paper 10 µm
M0060 Wire mesh 60 µm	P0025 Resin-impregnated paper 25 µm
M0090 Wire mesh 90 µm	
M0250 Wire mesh 250 µm	

Element Δp
A 1 bar

Seals and treatments	M0xxx	P0xxx
A NBR	•	•
V FPM	•	•
W NBR with filter and components surface treatment	•	-
Z FPM with filter and components surface treatment	•	-

Bypass
00 Without bypass
03 With bypass 0.03 MPa (0.3 bar)

Connections	
FG100 G 1"	FS016 SAE 16 - 1 5/16" - 12 UN
FG114 G 1 1/4"	FS020 SAE 20 - 1 5/8" - 12 UN
FG112 G 1 1/2" G 1"	FS024 SAE 24 - 1 7/8" - 12 UN SAE 16 - 1 5/16" - 12 UN
FN100 1" NPT	FE112 1 1/2" SAE 3000 psi/M
FN114 1 1/4" NPT	FF112 1 1/2" SAE 3000 psi/UNC
FN112 1 1/2" NPT	Available additional connections

Additional connections	FG112	FS024
0 Without additional connections	-	-
1 With smaller additional connections	G1"	SAE 16 - 1 5/16" - 12 UN

Connections for clogging indicators
5T With rear indicator connection, with metal plugs

Additional features
NN Without additional features
MA With magnetic filter

Version
P01 Standard catalogue item

Certificates
NN None

CLOGGING INDICATORS

See page 775

VEA Electrical vacuum indicator	VVA Axial vacuum gauge
VLA Electrical / visual vacuum indicator	VVR Radial vacuum gauge

FILTER ELEMENT											
Series	Example 1: SMC 250 10 M0025 A A 00 NN P01 NN										
SMC	Example 2: SMC 250 10 P0010 A V 00 NN P01 NN										
Size											
250											
Length											
10											
Filtration rating (filter media)											
M0025 Wire mesh 25 µm	P0010 Resin-impregnated paper 10 µm										
M0060 Wire mesh 60 µm	P0025 Resin-impregnated paper 25 µm										
M0090 Wire mesh 90 µm											
M0250 Wire mesh 250 µm											
Element Δp											
A 1 bar											
Seals and treatments											
A NBR											
V FPM											
Bypass											
00 Without bypass											
Additional features											
NN Without											
Version											
P01 Standard catalogue item											
Certificates											
NN None											

SFMC 250

Dimensions

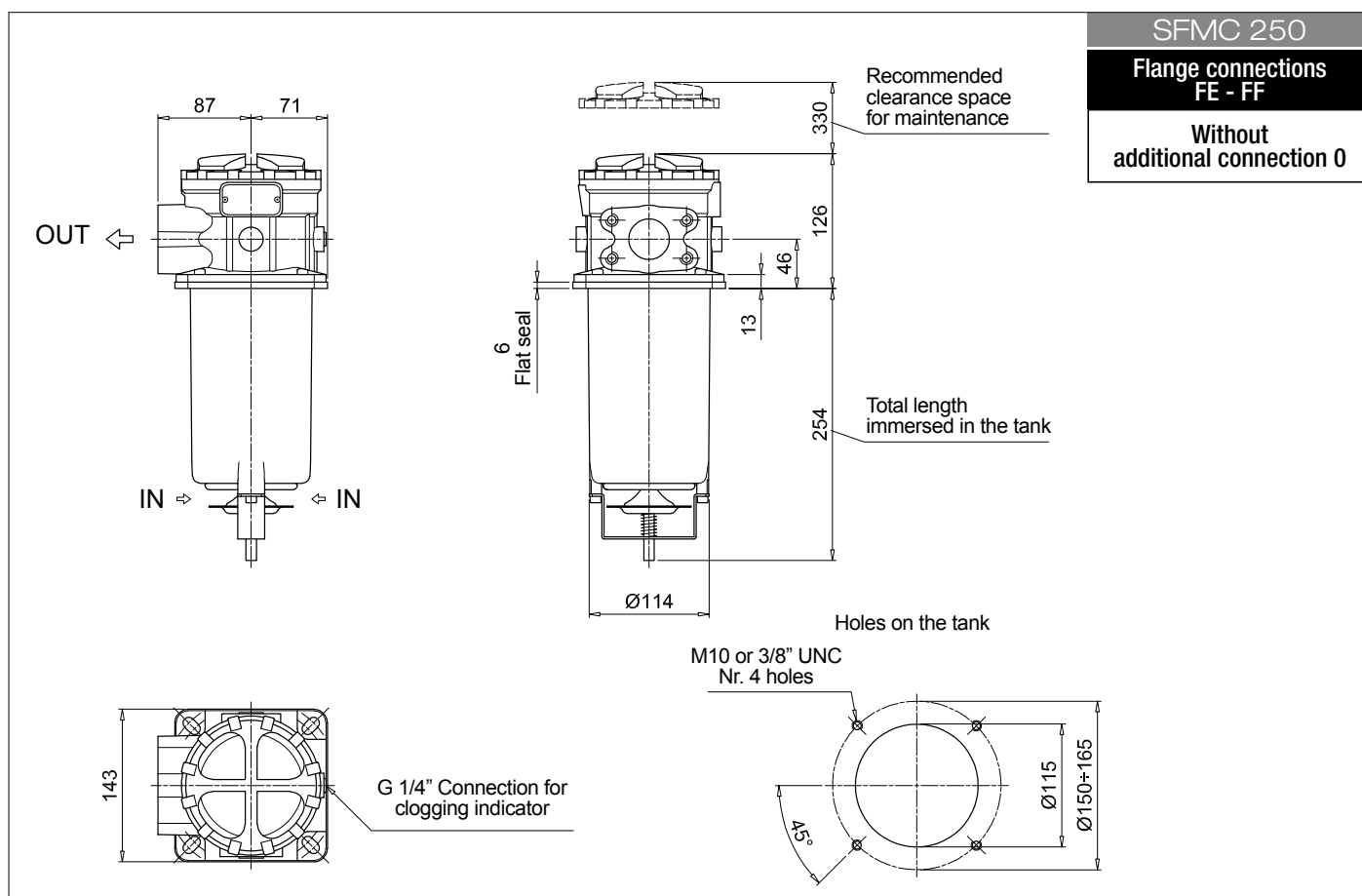
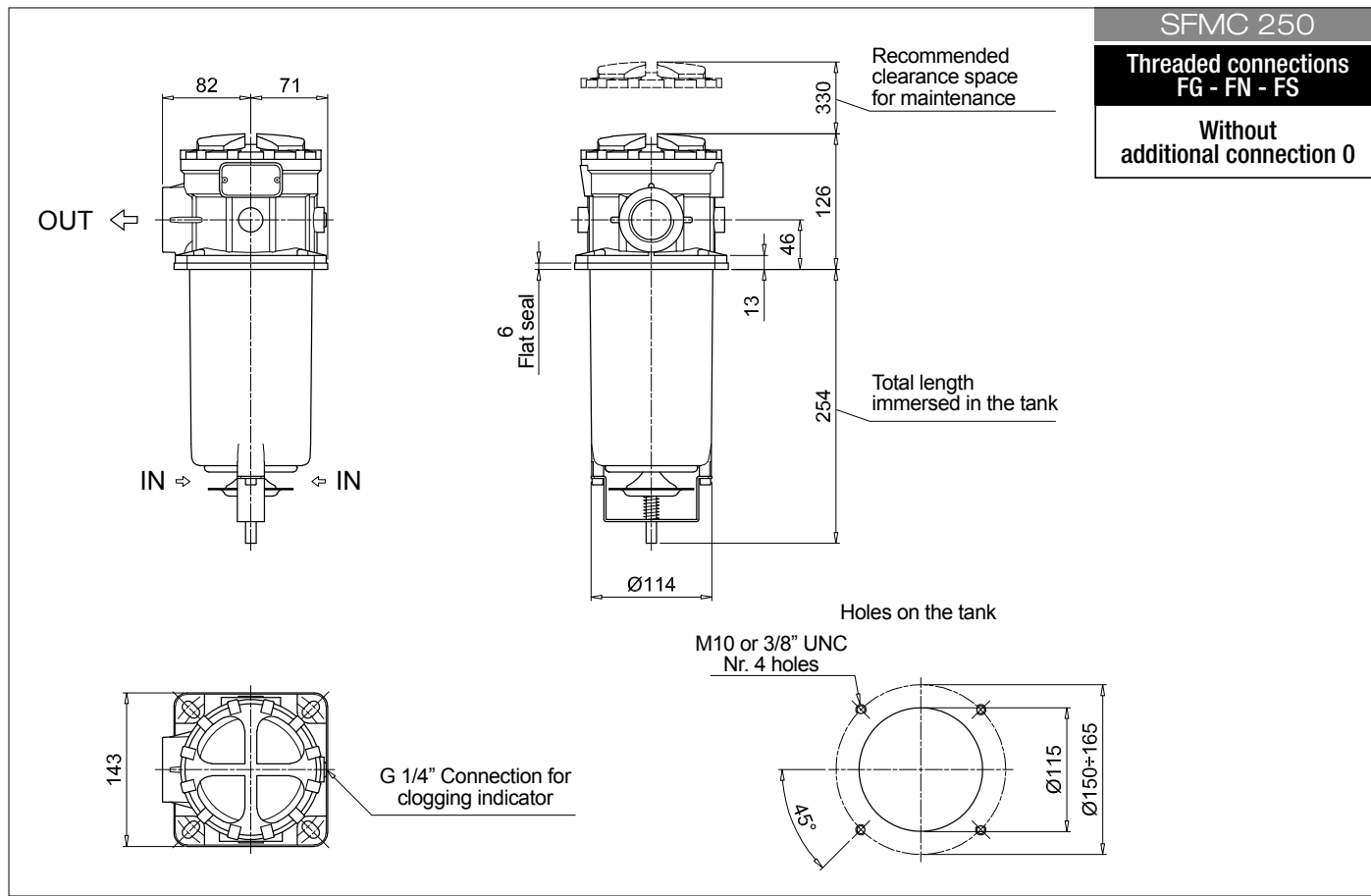

SFMC 250

With smaller additional connection 1

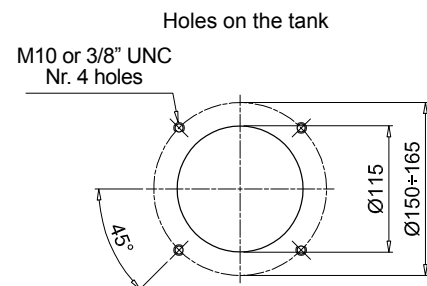
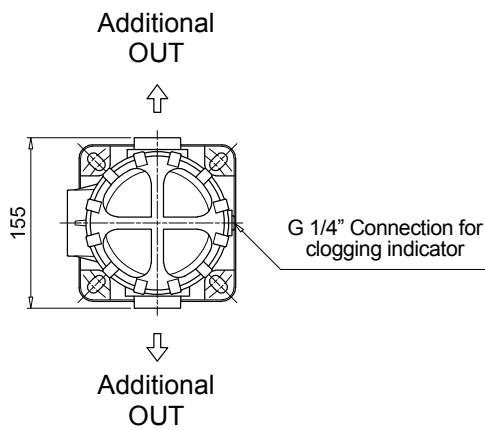
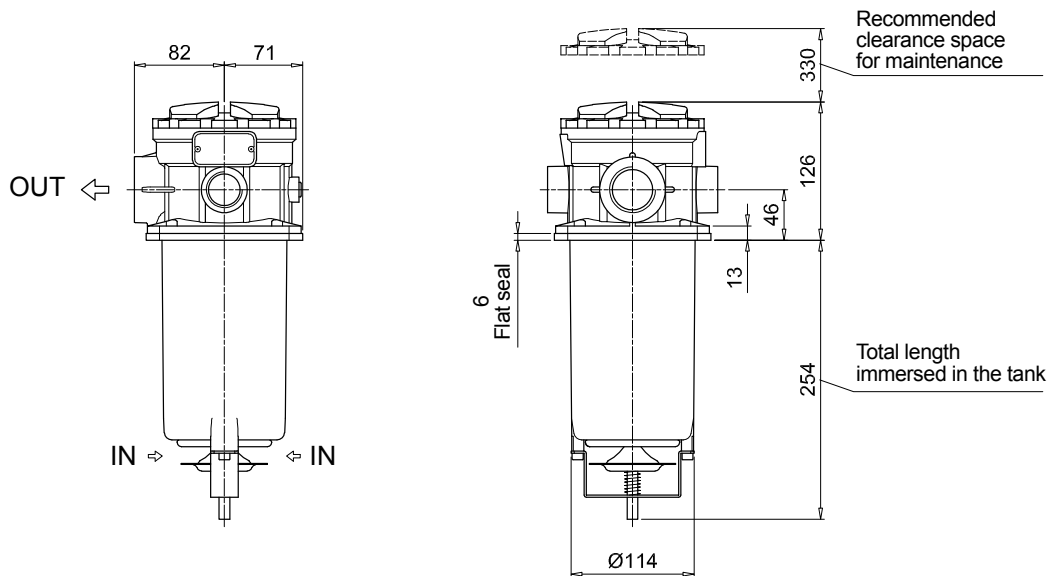

SFMC 250 SPARE PARTS

Order number for spare parts

SFMC 250

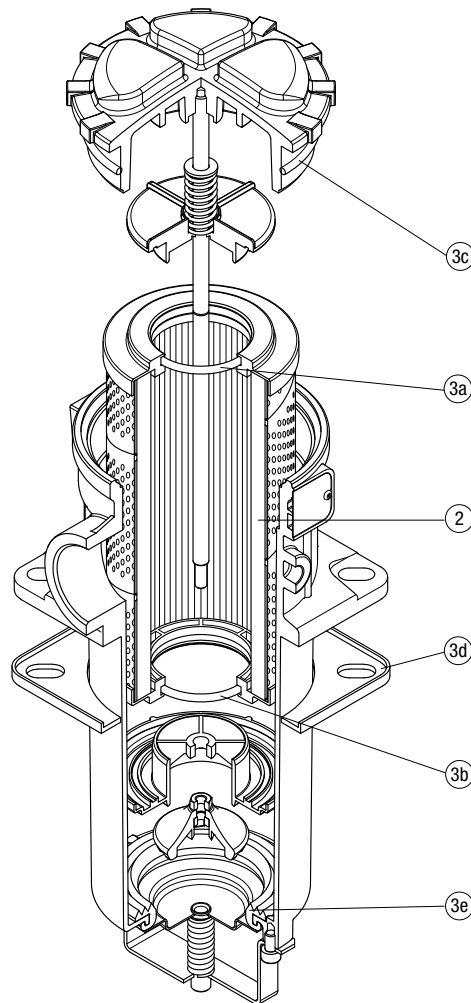

Item:	Q.ty: 1 pc.	Q.ty: 1 pc.	
Filter series	Filter element	Seal Kit code number	
		NBR	FPM
SFMC 250	See order table	02050586	02050587