

MPS series

Maximum working pressure up to 1.2 MPa (12 bar) - Flow rate up to 365 l/min



Description

Spin-on filters

Maximum working pressure up to 1.2 MPa (12 bar)
Flow rate up to 365 l/min

MPS is a range of spin-on filters suitable to be used in suction, return and low pressure lines.

They offer a good balance between performances, dimensions and prices. They are directly connected to the lines of the system through the hydraulic fittings.

Available features:

- Female threaded connections up to 1 1/2" and flanged connections up to 1 1/2", for a maximum flow rate of 365 l/min
- Fine filtration rating, to get a good cleanliness level into the reservoir
- Water removal elements (CW), to remove the free water from the hydraulic fluid
- Double connection for the cans, to fit both European and American standard elements
- Double cans fitting, to increase the life time of the filter
- Bypass valve, to relieve excessive pressure drop across the filter media
- Visual, electrical and electronic clogging indicators for suction and return applications
- Visual, electrical and electronic differential clogging indicators for low pressure applications

Common applications:

- Suction lines, Return lines, Delivery lines, in economic industrial equipment or mobile machines.
- Off-line filtration tank in economic industrial equipment or mobile machines

Technical data

Filter housing materials

- Head: Aluminium
- Bypass valve: Polyamide - Steel
- Element: Zinc-Plated Steel - Painted steel

Pressure

- Test pressure: 1.8 MPa (18 bar)
- Min. Burst pressure: 3.6 MPa (36 bar)
- Pulse pressure fatigue test: 1 000 000 cycles with pressure from 0 to 1.2 MPa (12 bar)

Bypass valve

- Inline / Return filter opening pressure: 0.175 MPa (1.75 bar) $\pm 10\%$
- Inline / Suction filter opening pressure: 0.03 MPa (0.3 bar) $\pm 10\%$

Filter element features

Filter MPS	Filter element CS	
Δp Element type		
Element media	Construction	Δp
A - Microfiber	Standard	5 bar
M - Wire mesh	Standard	5 bar
P - Paper	Standard	5 bar
<i>Please see ordering code tables to check element Δp series availability based on filter features.</i>		
Flow direction through the filter element: From OUT to IN		

Seals

Standard NBR - series A

Temperature

From -20 °C to +110 °C

Note

MPS filters are provided for vertical mounting

Weights [kg] and volumes [dm³]

Filter series	Weights [kg]	Volumes [dm ³]
MPS 050	1.00	0.70
MPS 051	1.05	0.70
MPS 070	1.20	0.95
MPS 071	1.25	0.95
MPS 100	2.10	1.65
MPS 101	2.20	1.65
MPS 150	2.40	2.00
MPS 151	2.50	2.00
MPS 200	3.90	3.00
MPS 250	4.60	3.70
MPS 300-301	5.30	3.40
MPS 350-351	6.00	4.10

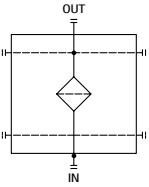
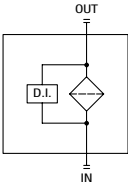
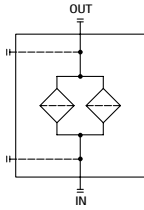
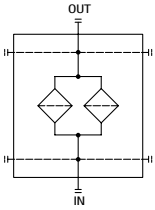
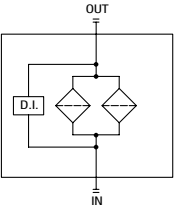
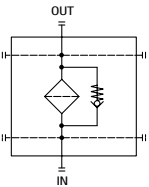
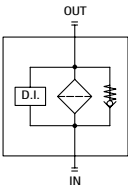
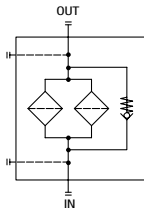
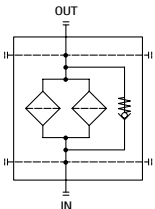
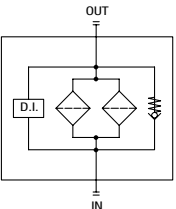
Filter series					
MPS 050	•	-	-	-	-
MPS 051	-	•	-	-	-
MPS 070	•	-	-	-	-
MPS 071	-	•	-	-	-
MPS 100	•	-	-	-	-
MPS 101	-	•	-	-	-
MPS 150	•	-	-	-	-
MPS 151	-	•	-	-	-
MPS 200	-	-	•	-	-
MPS 250	-	-	•	-	-
MPS 300	-	-	-	•	-
MPS 301	-	-	-	-	•
MPS 350	-	-	-	•	-
MPS 351	-	-	-	-	•
	Style U/P	Style U/P	Style U	Style U/P	Style U/P
					
	Style R/S	Style R/S	Style R/S	Style R/S	Style R/S
					

Pressure drop

Bypass valve
pressure drop

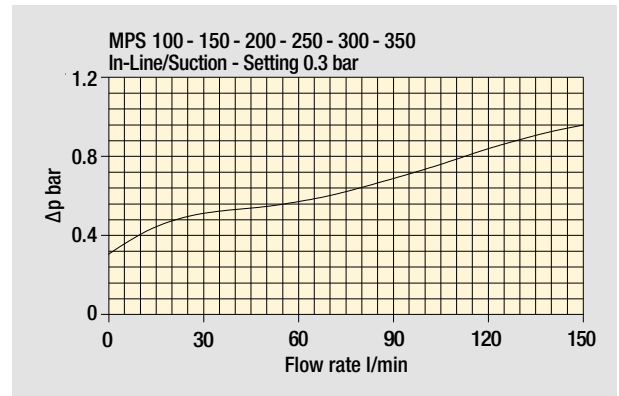
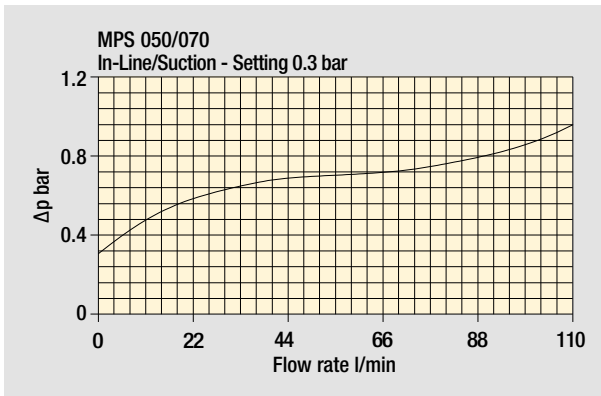
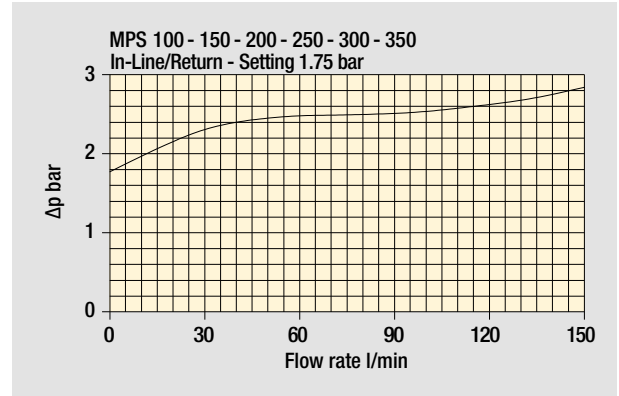
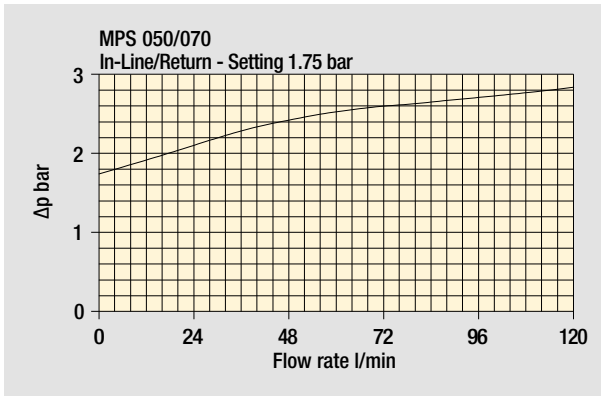

The curves are plotted using mineral oil with density of 0.86 kg/dm³ in compliance with ISO 3968. Δp varies proportionally with density.

CS 050 - 070 - 100 - 150

CG - CW 050 - 070



CG - CW 100 - 150



CW

This series of cartridge removes water from oil while filtering the oil at the same time.

Water absorbent polymers up to 800 times their own weight provide this major feature.

Water holding capacities:
CW 050= 240 ml

Ordering code: **CW050P10AP01**

CW 150= 788 ml

Ordering code: **CW150P10AP01**

Thread connections

Element	Connection
CS 050 - 070	G 3/4"
CS 100 - 150	G 1 1/4"
CG / CW 050 - 070	1" - 12 UNF
CG / CW 100 - 150	1 1/2" - 16 UN

Water holding capacities CW

	good	poor
Viscosity	30/46 mm ² /s (cSt)	> 46 mm ² /s (cSt)
H ₂ O p.p.m.	600/800 p.p.m.	> 800 p.p.m.
Flow rate	CW050 7/15 l/min CW150 20/40 l/min	CW050 > 20 l/min CW150 > 50 l/min
Temperature	40/60 °C	< 30 °C

Heads

CS 050 - 070

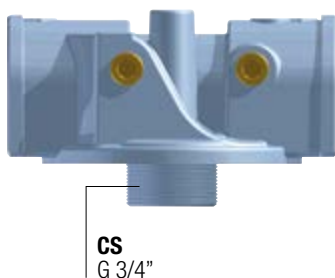

CG / CW 050 - 070

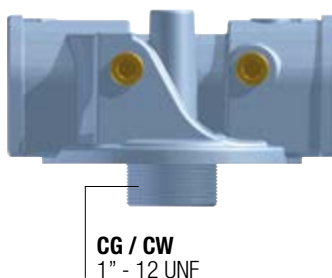

CS / CG / CW 100 - 150

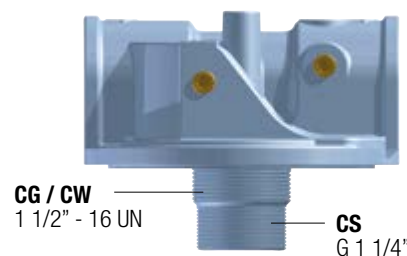

CG and CW cartridges are not foreseen as first equipment supply for MPS filters; they can be provided only as loose spare parts.

For this reason, only CS cartridges are foreseen as first equipment supply in the following Designation & Ordering code pages for MPS filters.

MPS MPS050 - MPS070 MPS051 - MPS071

Designation & Ordering code

COMPLETE FILTER

Series and size		Configuration example: MPS050 R G1 A10 A P01				
MPS050 MPS070	With connections for clogging indicators					
MPS051 MPS071	With connections for differential pressure indicators					
Bypass valve		MPS 050 - 070	MPS 051 - 071			
R	Inline / Return: with bypass 1.75 bar	•	•			
S	Inline / Suction: with bypass 0.3 bar	•	-			
U	Without bypass	•	-			
P	Without bypass	-	•			
Connections						
G1	G 3/4"					
G2	3/4" NPT					
G3	SAE 12 - 1 1/16" - 12 UN					
Filtration rating (filter media)						
A03	Inorganic microfiber 3 µm	M25	Wire mesh 25 µm			
A06	Inorganic microfiber 6 µm	M60	Wire mesh 60 µm			
A10	Inorganic microfiber 10 µm	M90	Wire mesh 90 µm			
A25	Inorganic microfiber 25 µm	P10	Resin impregnated paper 10 µm			
		P25	Resin impregnated paper 25 µm			
		Seal		Execution		
		A NBR		P01 MP Filtri standard		

CARTRIDGE

Cartridge series and size		Configuration example: CS050 A10 A P01			
CS050 CS070					
Filtration rating (filter media)					
A03	Inorganic microfiber 3 µm	M25	Wire mesh 25 µm		
A06	Inorganic microfiber 6 µm	M60	Wire mesh 60 µm		
A10	Inorganic microfiber 10 µm	M90	Wire mesh 90 µm		
A25	Inorganic microfiber 25 µm	P10	Resin impregnated paper 10 µm		
		P25	Resin impregnated paper 25 µm		
		Seals		Execution	
		A NBR		P01 MP Filtri standard Pxx Customized	

CLOGGING INDICATORS

See pages 781-783

Clogging indicators on RETURN line

BVA	Axial pressure gauge
BVR	Radial pressure gauge
BVP	Visual pressure indicator with automatic reset
BVQ	Visual pressure indicator with manual reset

BEA	Electrical pressure indicator
BEM	Electrical pressure indicator
BET	Electrical pressure indicator
BLA	Electrical / visual pressure indicator

Clogging indicators on SUCTION line

VVB	Axial pressure gauge
VVS	Radial pressure gauge

VEB	Electrical vacuum indicator
VLB	Electrical / visual vacuum indicator

Differential pressure indicators

DEA	Electrical differential pressure indicator
DEM	Electrical differential pressure indicator
DEU	Electrical differential pressure indicator
DLA	Electrical / visual differential pressure indicator
DLE	Electrical / visual differential pressure indicator

DTA	Electronic differential pressure indicator
DTI	I-O Link electronic differential pressure indicator
DVA	Visual differential pressure indicator
DVM	Visual differential pressure indicator

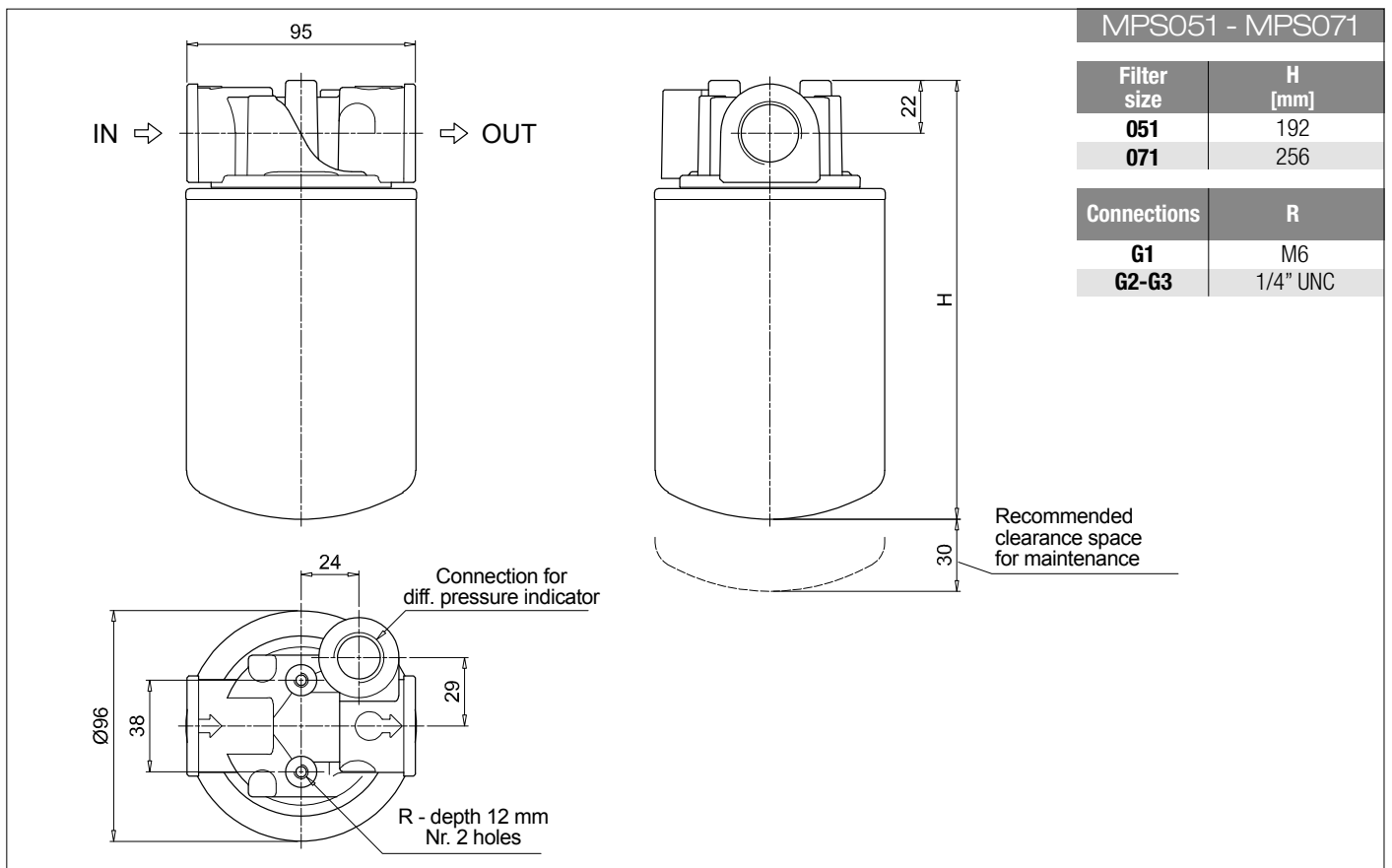
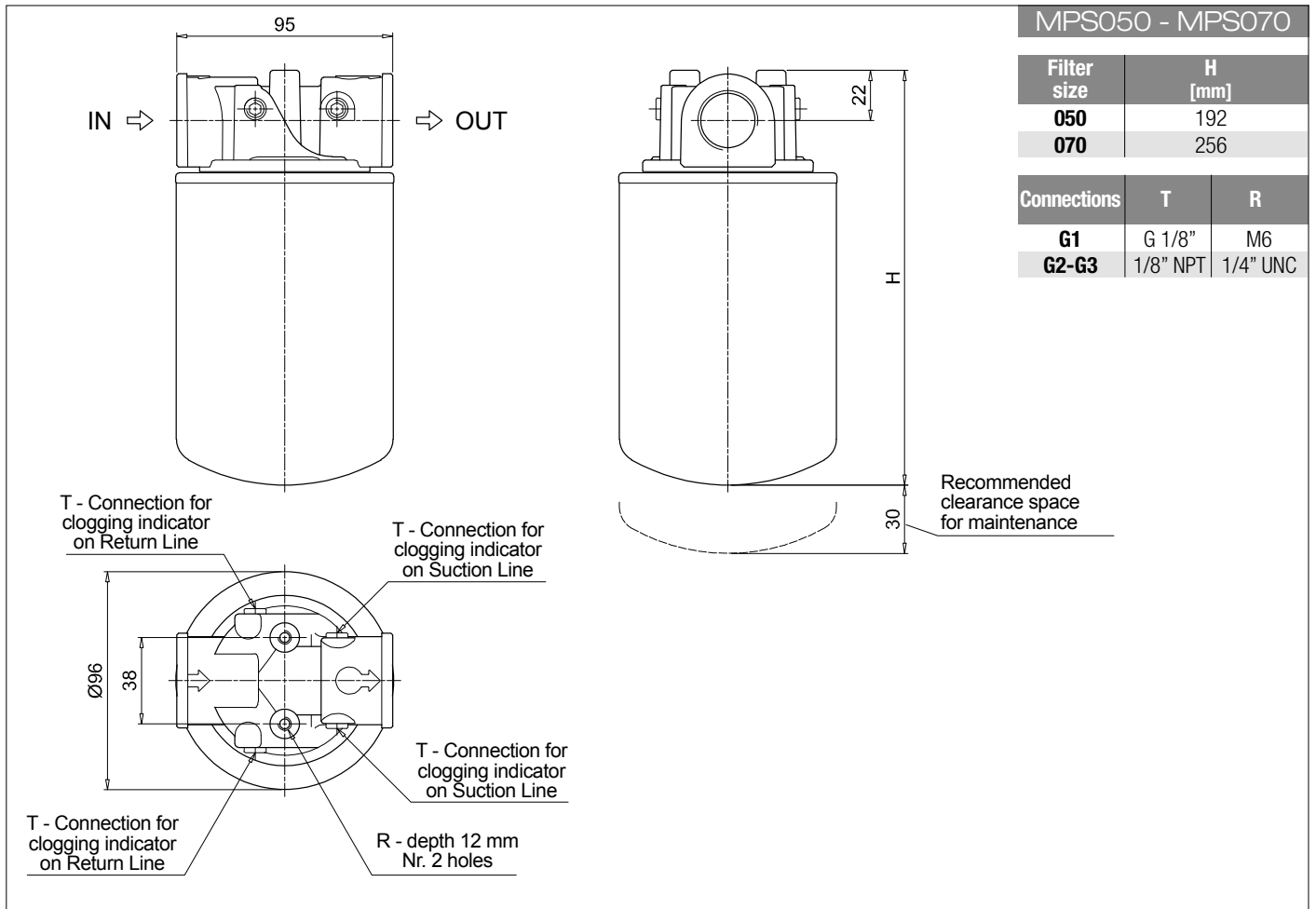

MPS MPS100 - MPS150 MPS101 - MPS151

Designation & Ordering code

COMPLETE FILTER

Series and size		Configuration example: MPS100 R G1 A10 A P01				
MPS100 MPS150	With connections for clogging indicators					
MPS101 MPS151	With connections for differential pressure indicators					
Bypass valve		MPS 100 - 150	MPS 101 - 151			
R	Inline / Return: with bypass 1.75 bar	•	•			
S	Inline / Suction: with bypass 0.3 bar	•	-			
U	Without bypass	•	-			
P	Without bypass	-	•			
Connections						
G1	G 1 1/4"					
G2	1 1/4" NPT					
G3	SAE 20 - 1 5/8" - 12 UN					
Filtration rating (filter media)						
A03	Inorganic microfiber 3 µm	M25	Wire mesh	25 µm		
A06	Inorganic microfiber 6 µm	M60	Wire mesh	60 µm		
A10	Inorganic microfiber 10 µm	M90	Wire mesh	90 µm		
A25	Inorganic microfiber 25 µm	P10	Resin impregnated paper	10 µm		
		P25	Resin impregnated paper	25 µm		
		Seal		Execution		
		A NBR		P01 MP Filtri standard		

CARTRIDGE

Cartridge series and size		Configuration example: CS100 A10 A P01			
CS100 CS150					
Filtration rating (filter media)					
A03	Inorganic microfiber 3 µm	M25	Wire mesh	25 µm	
A06	Inorganic microfiber 6 µm	M60	Wire mesh	60 µm	
A10	Inorganic microfiber 10 µm	M90	Wire mesh	90 µm	
A25	Inorganic microfiber 25 µm	P10	Resin impregnated paper	10 µm	
		P25	Resin impregnated paper	25 µm	
		Seals		Execution	
		A NBR		P01 MP Filtri standard Pxx Customized	

CLOGGING INDICATORS

See pages 781-783

Clogging indicators on RETURN line

BVA	Axial pressure gauge
BVR	Radial pressure gauge
BVP	Visual pressure indicator with automatic reset
BVQ	Visual pressure indicator with manual reset

BEA	Electrical pressure indicator
BEM	Electrical pressure indicator
BET	Electrical pressure indicator
BLA	Electrical / visual pressure indicator

Clogging indicators on SUCTION line

VVB	Axial pressure gauge
VVS	Radial pressure gauge

VEB	Electrical vacuum indicator
VLB	Electrical / visual vacuum indicator

Differential pressure indicators

DEA	Electrical differential pressure indicator
DEM	Electrical differential pressure indicator
DEU	Electrical differential pressure indicator
DLA	Electrical / visual differential pressure indicator
DLE	Electrical / visual differential pressure indicator

DTA	Electronic differential pressure indicator
DTI	I-O Link electronic differential pressure indicator
DVA	Visual differential pressure indicator
DVM	Visual differential pressure indicator

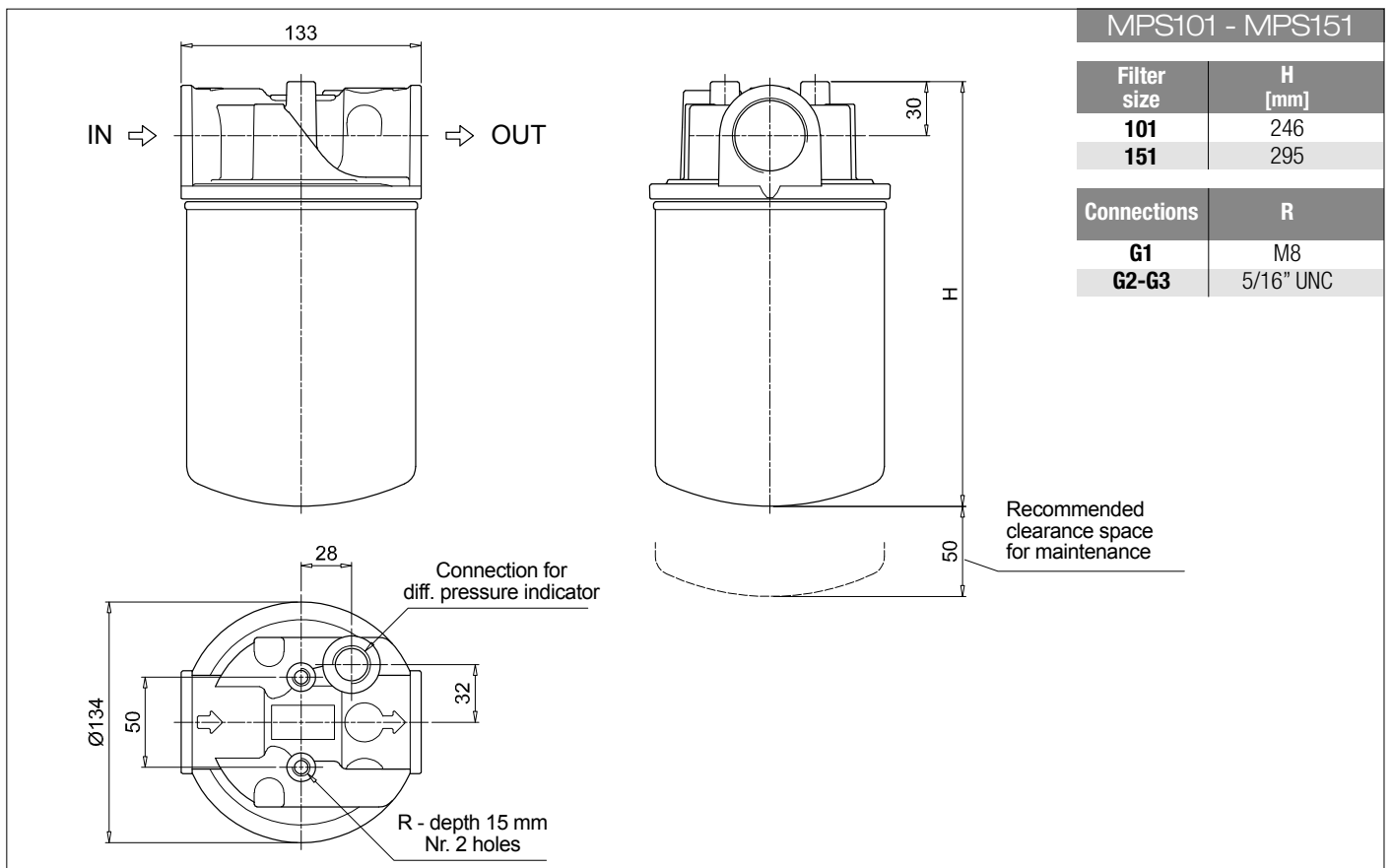
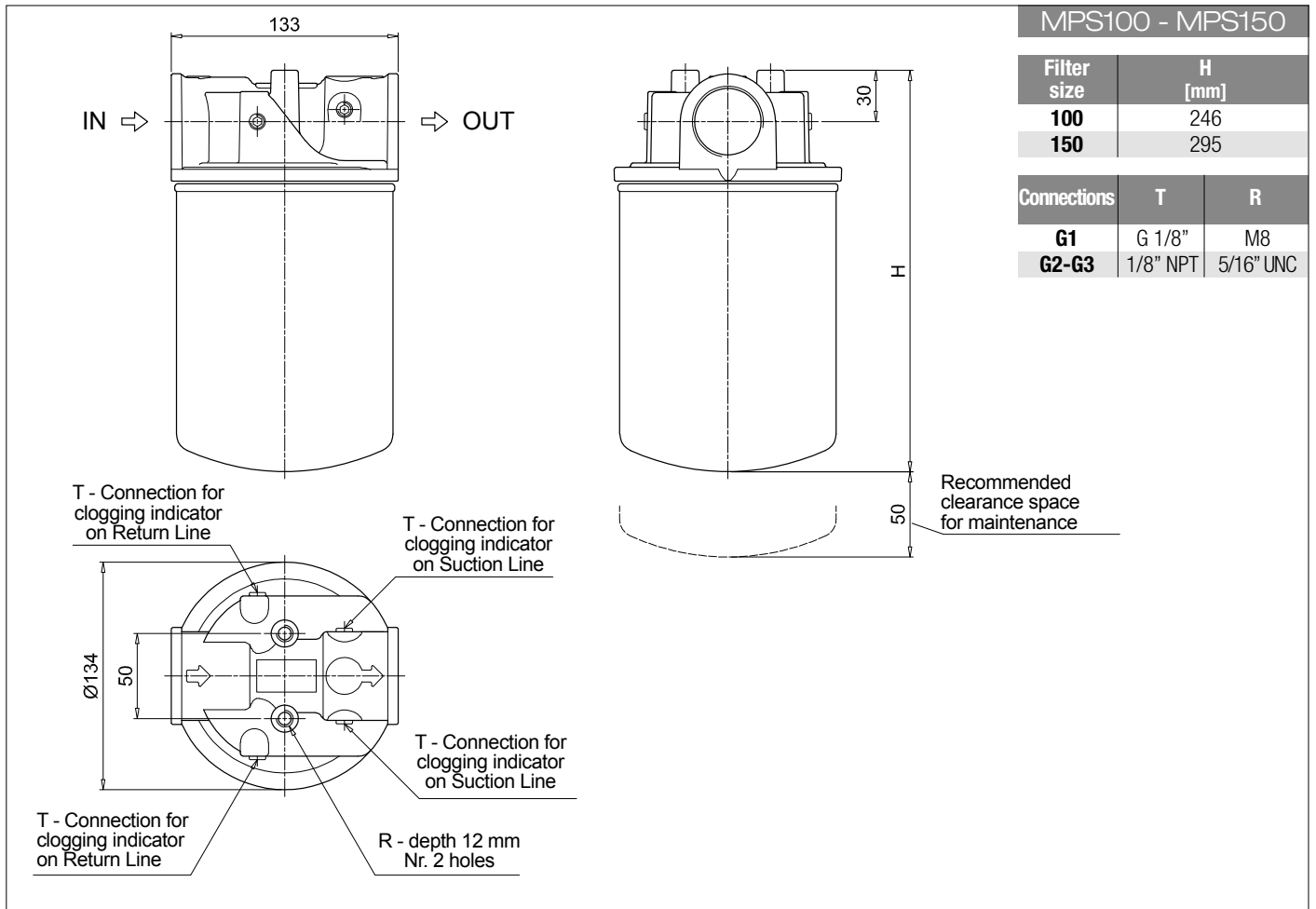

MPS MPS200 - MPS250

Designation & Ordering code

COMPLETE FILTER

Series and size

MPS200 | **MPS250**

Configuration example: **MPS200** **R** **G1** **A10** **A** **P01**

Bypass valve

R Inline / Return: with bypass 1.75 bar

S Inline / Suction: with bypass 0.3 bar

U Without bypass

Connections

G1 G 1 1/2"

G2 1 1/2" NPT

G3 SAE 24 - 1 7/8" - 12 UN

Filtration rating (filter media)

A03 Inorganic microfiber 3 µm **M25** Wire mesh 25 µm

A06 Inorganic microfiber 6 µm **M60** Wire mesh 60 µm

A10 Inorganic microfiber 10 µm **M90** Wire mesh 90 µm

A25 Inorganic microfiber 25 µm **P10** Resin impregnated paper 10 µm

P25 Resin impregnated paper 25 µm

Seal

A NBR

Execution

P01 MP Filtri standard

CARTRIDGE

Cartridge series and size

CS100 | **CS150**

Configuration example: **CS100** **A10** **A** **P01**

Filtration rating (filter media)

A03 Inorganic microfiber 3 µm **M25** Wire mesh 25 µm

A06 Inorganic microfiber 6 µm **M60** Wire mesh 60 µm

A10 Inorganic microfiber 10 µm **M90** Wire mesh 90 µm

A25 Inorganic microfiber 25 µm **P10** Resin impregnated paper 10 µm

P25 Resin impregnated paper 25 µm

Seals

A NBR

Execution

P01 MP Filtri standard

Pxx Customized

CLOGGING INDICATORS

See pages 781-783

Clogging indicators on RETURN line

BVA Axial pressure gauge

BVR Radial pressure gauge

BVP Visual pressure indicator with automatic reset

BVQ Visual pressure indicator with manual reset

BEA Electrical pressure indicator

BEM Electrical pressure indicator

BET Electrical pressure indicator

BLA Electrical / visual pressure indicator

Clogging indicators on SUCTION line

VVB Axial pressure gauge

VVS Radial pressure gauge

VEB Electrical vacuum indicator

VLB Electrical / visual vacuum indicator

MPS200 - MPS250

Filter size	H [mm]
200	213
250	262

Connections	T	R
G1	G 1/8"	M10
G2-G3	1/8" NPT	7/16" UNC

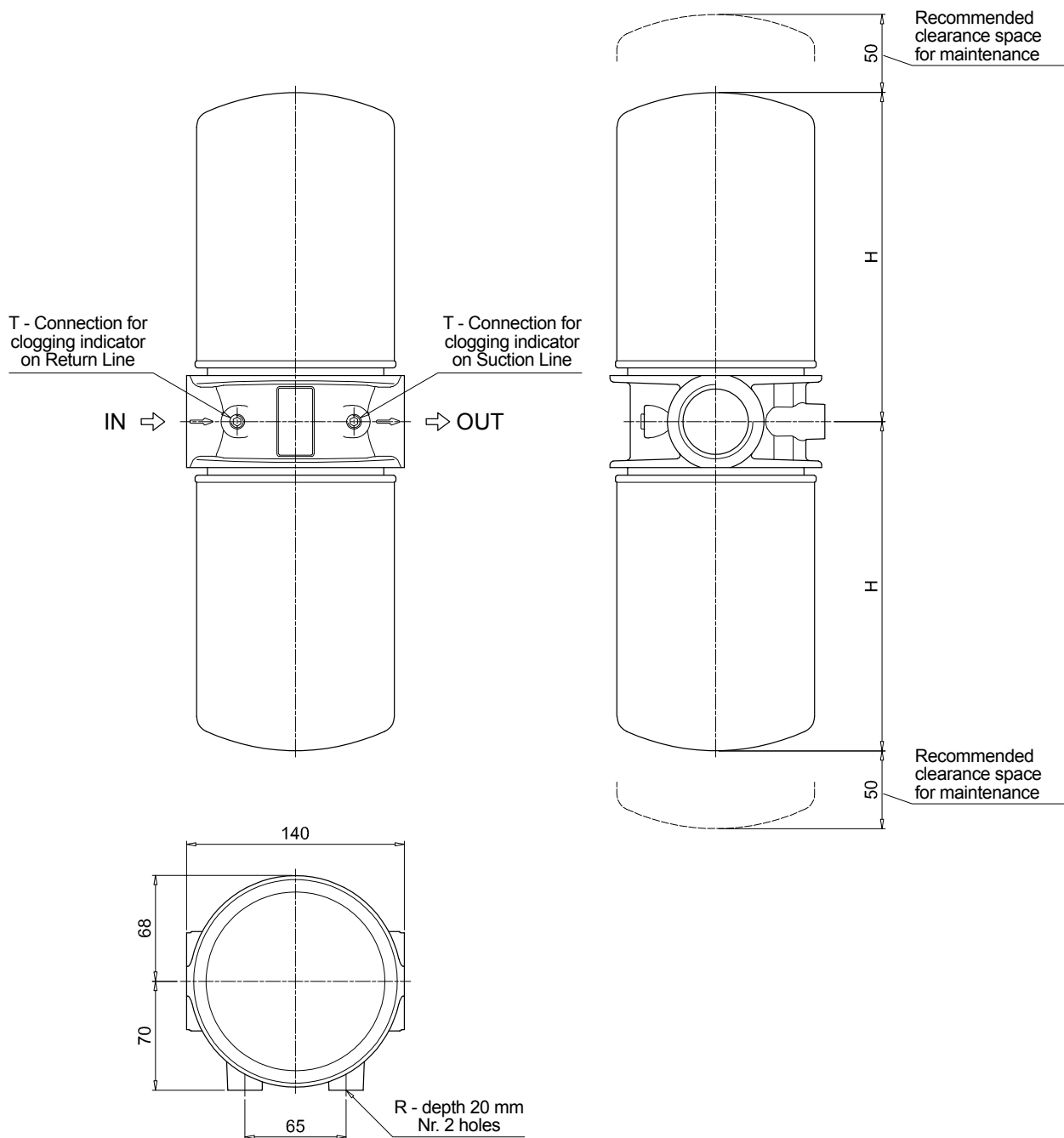

MPS MPS300 - MPS350 MPS301 - MPS351

Designation & Ordering code

COMPLETE FILTER

Series and size		Configuration example: MPS300 R F1 A10 A P01				
MPS300 MPS350	With connections for clogging indicators					
MPS301 MPS351	With connections for differential pressure indicators					
Bypass valve		MPS 300 - 350	MPS 301 - 351			
R	Inline / Return: with bypass 1.75 bar	•	•			
S	Inline / Suction: with bypass 0.3 bar	•	-			
U	Without bypass	•	-			
P	Without bypass	-	•			
Connections						
G1	G 1 1/2"					
G2	1 1/2" NPT					
G3	SAE 24 - 1 7/8" - 12 UN					
F1	1 1/2" SAE 3000 psi/M					
F2	1 1/2" SAE 3000 psi/UNC					
Filtration rating (filter media)						
A03	Inorganic microfiber 3 µm	M25	Wire mesh 25 µm			
A06	Inorganic microfiber 6 µm	M60	Wire mesh 60 µm			
A10	Inorganic microfiber 10 µm	M90	Wire mesh 90 µm			
A25	Inorganic microfiber 25 µm	P10	Resin impregnated paper 10 µm			
		P25	Resin impregnated paper 25 µm			
		Seal		Execution		
		A NBR		P01 MP Filtri standard		

CARTRIDGE

Cartridge series and size		Configuration example: CS100 A10 A P01			
CS100 CS150					
Filtration rating (filter media)					
A03	Inorganic microfiber 3 µm	M25	Wire mesh 25 µm		
A06	Inorganic microfiber 6 µm	M60	Wire mesh 60 µm		
A10	Inorganic microfiber 10 µm	M90	Wire mesh 90 µm		
A25	Inorganic microfiber 25 µm	P10	Resin impregnated paper 10 µm		
		P25	Resin impregnated paper 25 µm		
		Seals		Execution	
		A NBR		P01 MP Filtri standard	
				Pxx Customized	

CLOGGING INDICATORS

See pages 781-783

Clogging indicators on RETURN line

BVA	Axial pressure gauge
BVR	Radial pressure gauge
BVP	Visual pressure indicator with automatic reset
BVQ	Visual pressure indicator with manual reset

BEA	Electrical pressure indicator
BEM	Electrical pressure indicator
BET	Electrical pressure indicator
BLA	Electrical / visual pressure indicator

Clogging indicators on SUCTION line

VVB	Axial pressure gauge
VVS	Radial pressure gauge

VEB	Electrical vacuum indicator
VLB	Electrical / visual vacuum indicator

Differential pressure indicators

DEA	Electrical differential pressure indicator
DEM	Electrical differential pressure indicator
DEU	Electrical differential pressure indicator
DLA	Electrical / visual differential pressure indicator
DLE	Electrical / visual differential pressure indicator

DTA	Electronic differential pressure indicator
DTI	I-O Link electronic differential pressure indicator
DVA	Visual differential pressure indicator
DVM	Visual differential pressure indicator

PLUGS

See page 807

T2	Plug (not included)
-----------	---------------------

MPS300 - MPS350

Filter size	H [mm]
300	266
350	315

Connections	T	R
G1	G 1/8"	M10
G2-G3	1/8" NPT	7/16" UNC
F1	G 1/8"	M10
F2	1/8" NPT	7/16" UNC

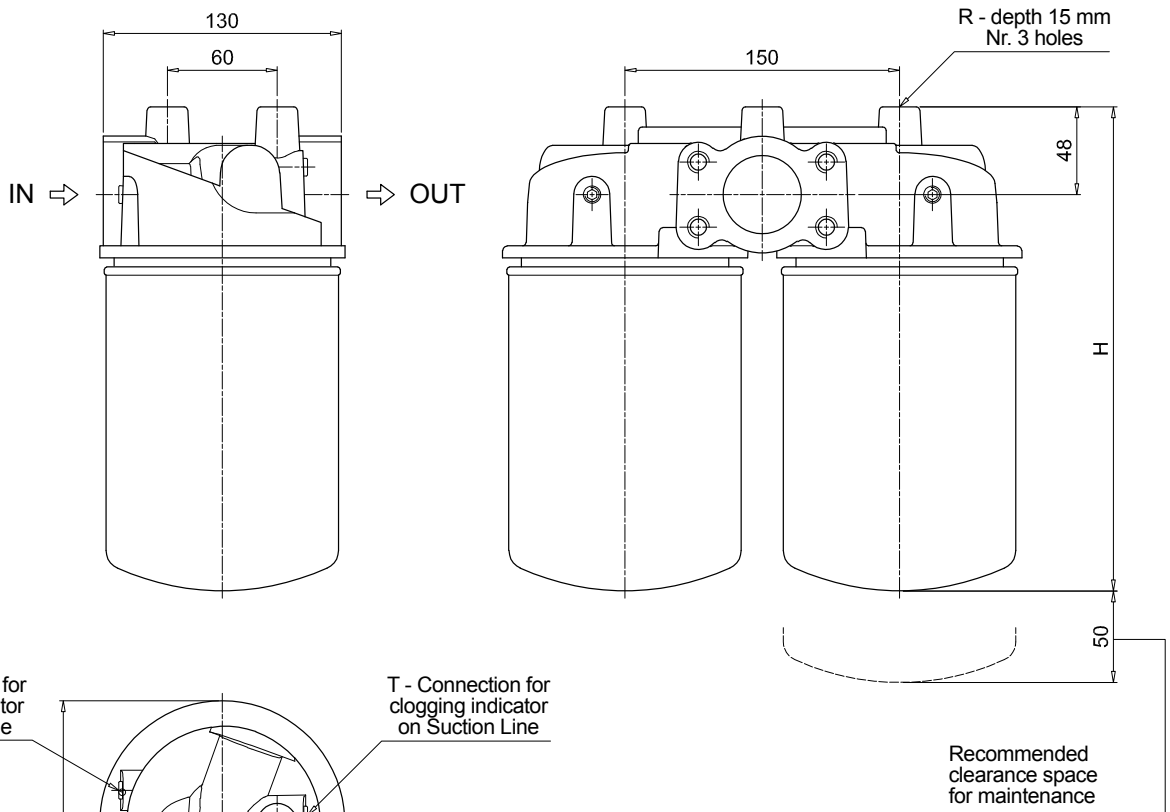

MPS MPS300 - MPS350 MPS301 - MPS351

Dimensions

MPS301 - MPS351

Filter size	H [mm]
301	266
351	315

Connections	R
G1	M10
G2-G3	7/16" UNC
F1	M10
F2	7/16" UNC

