

LMP 952-953-954 series

Maximum working pressure up to 2.5 MPa (25 bar) - Flow rate up to 4500 l/min



LMP 952-953-954 GENERAL INFORMATION

Description

Technical data

Low & Medium Pressure filters

Maximum working pressure up to 2.5 MPa (25 bar)
Flow rate up to 4500 l/min

LMP952, LMP953 and LMP954 are ranges of low pressure filter with large filtration surface mainly suitable for lubrication, off-line filtration of the reservoirs and filtration equipment.

Multiple LMP950 filters are connected to a manifold to reduce the pressure drop caused by the filter media and to increase the life time of the filter element.

They are directly connected to the lines of the system through the hydraulic fittings.

Available features:

- 4" flanged connections, for a maximum flow rate of 4500 l/min
- Base-mounting design, for ease of the replacement of the filter element
- Fine filtration rating, to get a good cleanliness level into the system
- Water removal elements, to remove the free water from the hydraulic fluid. For further information, see the Contamination Management document and the dedicate leaflet.
- Bypass valve, to relieve excessive pressure drop across the filter media
- Vent ports, to avoid air trapped into the filter going into the system
- Drain ports, to remove the fluid from the housing prior the maintenance work
- Visual, electrical and electronic differential clogging indicators

Common applications:

- Off-line filtration of reservoirs
- Filtration systems

Filter housing materials

- Head: Anodized Aluminium
- Housing: Anodized Aluminium
- Manifolds: Welded - Phosphatized Steel
- Bypass valve: Anodized Aluminium

Pressure

Test pressure: 3.5 MPa (35 bar)

Bypass valve

- Opening pressure 350 kPa (3.5 bar) \pm 10%
- Other opening pressures on request.

Δp element type

- Microfibre filter elements - series N: 20 bar
- Fluid flow through the filter element from OUT to IN

Number of filter elements

- LMP 952: 2 filter elements CU950-3
- LMP 953: 3 filter elements CU950-3
- LMP 954: 4 filter elements CU950-3

Seals

- Standard NBR series A
- Optional FPM series V

Temperature

From -25 °C to +110 °C

Connections

LMP 952-953-954:
In-line Inlet/Outlet

Note

LMP 952 - 953 - 954 filters
are provided for vertical mounting

Weights [kg] and volumes [dm³]

Filter series	Weights [kg]		Volumes [dm ³]	
	Length	3	Length	3
LMP 952		96		66
LMP 953		138		99
LMP 954		192		132

Flow rates [l/min]

Filter series	Length	Filter element design - N Series					
		A03	A06	A10	A16	A25	M25 M60 M90
LMP 952	3	2172	2294	2766	3106	3256	3998
LMP 953	3	2842	2964	3403	3696	3820	4395
LMP 954	3	3259	3372	3770	4026	4133	4618

Maximum flow rate for a complete low and medium pressure filter with a pressure drop $\Delta p = 0.7$ bar.

The reference fluid has a kinematic viscosity of 30 mm²/s (cSt) and a density of 0.86 kg/dm³.

For different pressure drop or fluid viscosity we recommend to use our selection software available on www.mpfiltri.com.

You can also calculate the right size using the formulas present on the FILTER SIZING paragraph at the beginning of the full catalogue or at the beginning of the filter family brochure. Please, contact our Sales Department for further additional information.

Hydraulic symbols

Filter series	Execution S - Execution B	Execution S - Execution B	Execution S - Execution B
LMP 952	•	-	-
LMP 953	-	•	-
LMP 954	-	-	•

S		S		S	
B		B		B	

LMP 952-953-954 GENERAL INFORMATION

Pressure drop

Filter housings Δp pressure drop

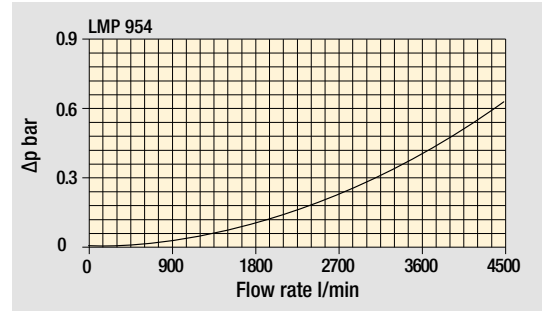
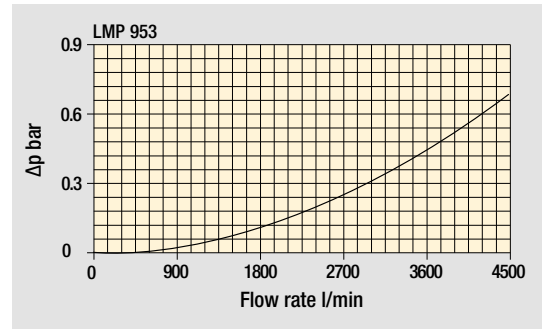
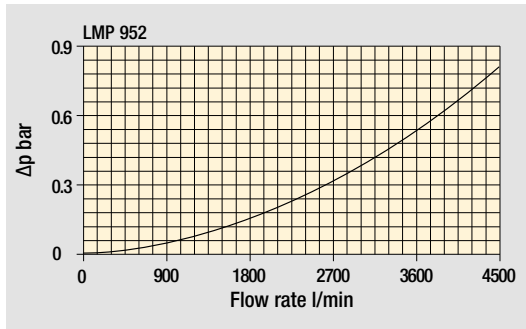

Pressure drop of filter complete with cartridge, oil viscosity 30 mm²/s (cSt)

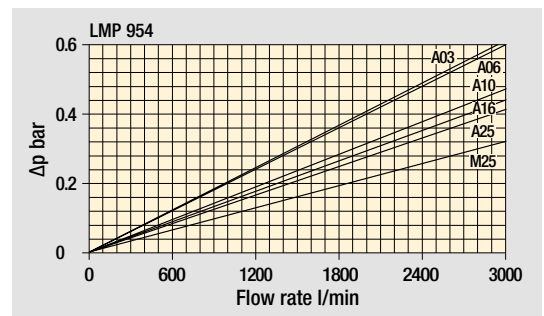
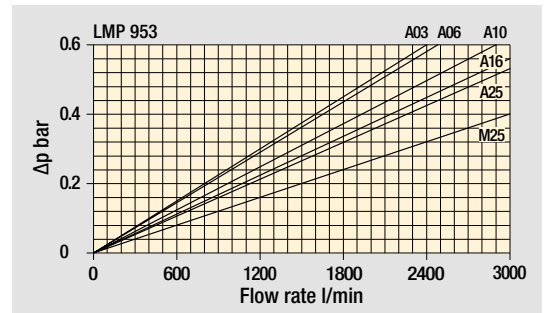
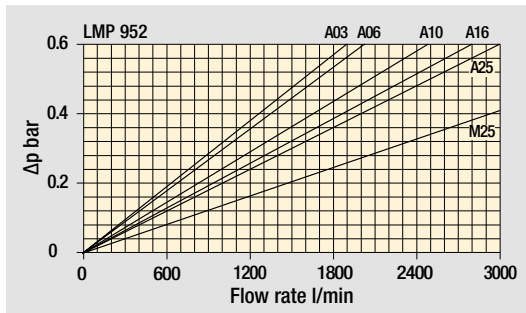

Bypass valve pressure drop

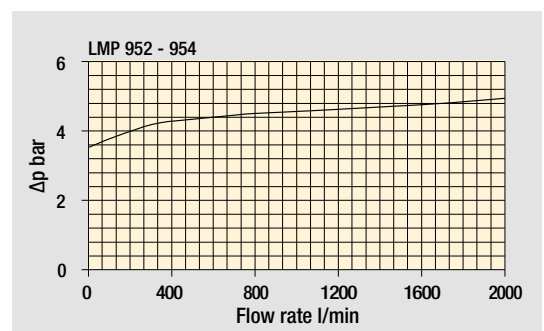

The curves are plotted using mineral oil with density of 0.86 kg/dm³ in compliance with ISO 3968. Δp varies proportionally with density.

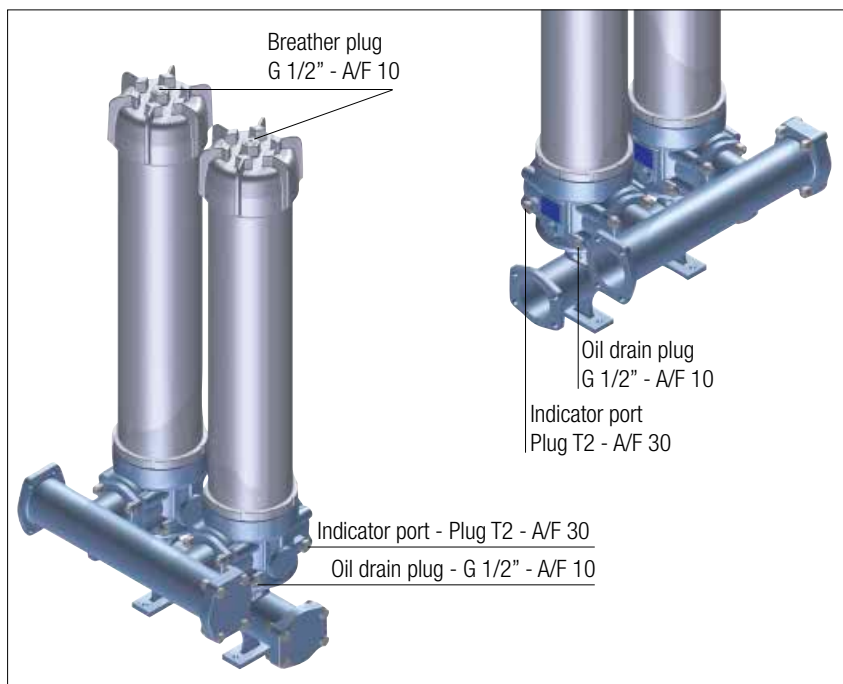
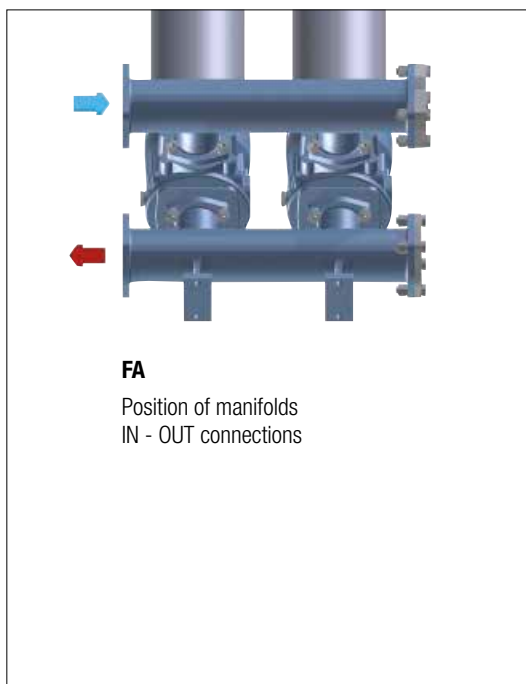

Execution P02

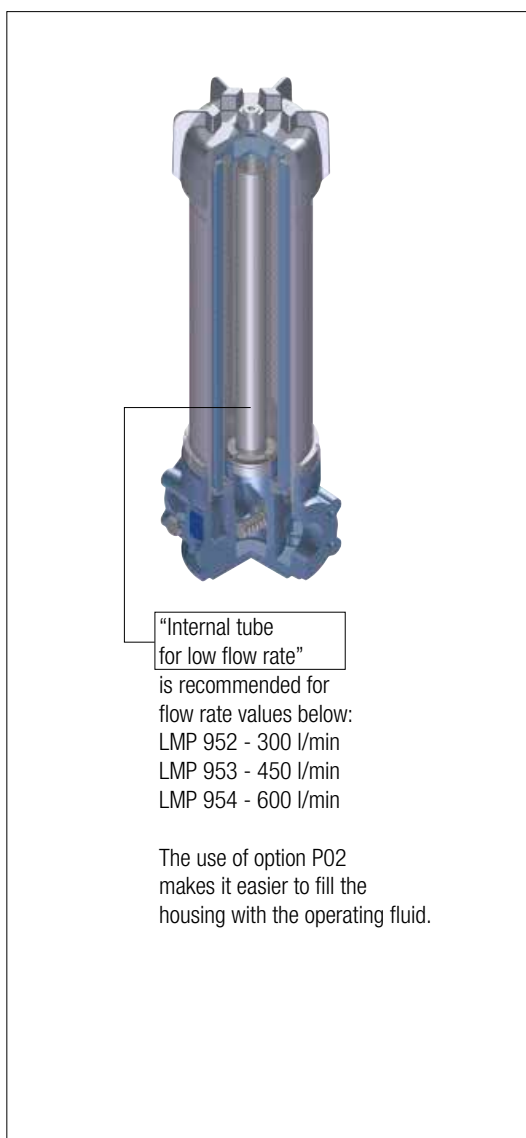

CMV4 & CUV4 Flange options

Code	Thread	Materials
CMV4	G 1 1/4"	1 - 4" SAE flange 2 - O-R 4437 (FPM) for flange 3 - Plug G 1-1/4" 4 - O-R 3168 for plug (FPM) 5 - No. 4 Hex bolt screws UNI-EN 24017 M16 x 65-10.9 6 - No. 4 Spring washers UNI 1751-B 16 7 - No. 4 Nuts UNI 5587 - M16
CUV4	SAE 20	1 - 4" SAE flange 2 - O-R 4437 (FPM) for flange 3 - Plug SAE 20 1 5/8" - 12 UN 4 - 1147 O-R for plug (FPM) 5 - No. 4 Hex bolt screws 5/8" UNC x 2 1/2" 6 - No. 4 Spring washers UNI 1751-B 16 7 - No. 4 Nuts 5/8" UNC

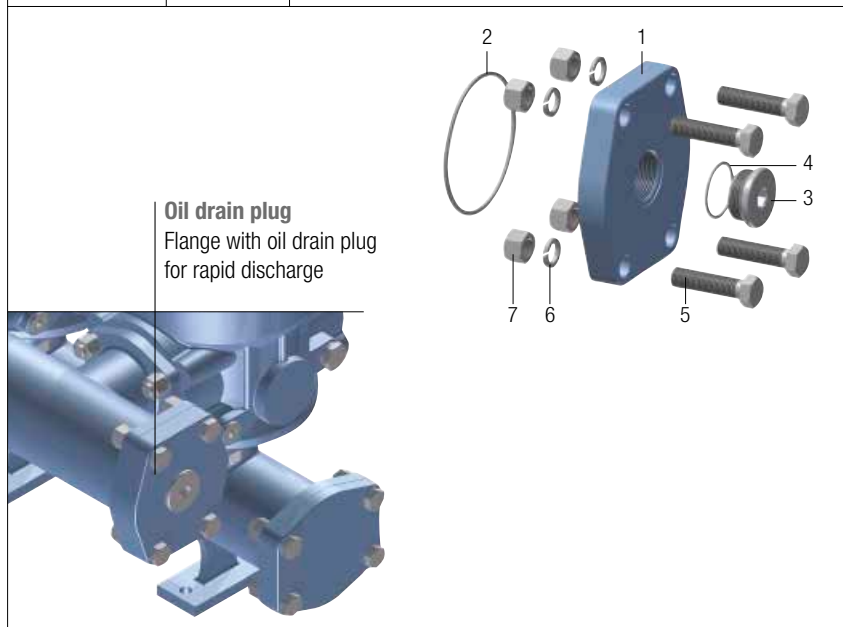

LMP 952-953-954

Designation & Ordering code

COMPLETE FILTER

Series and size **LMP952 | LMP953 | LMP954** Configuration example: **LMP952** **3** **B** **A** **FA** **A10** **N** **P01**

Length **3**

Bypass valve **S** Without bypass **B** With bypass 3.5 bar

Seals and treatments **A** NBR **V** FPM

Connections **FA** 4" SAE 3000 psi

Filtration rating (filter media)

A03 Inorganic microfiber 3 µm	M25 Wire mesh 25 µm
A06 Inorganic microfiber 6 µm	M60 Wire mesh 60 µm
A10 Inorganic microfiber 10 µm	M90 Wire mesh 90 µm
A16 Inorganic microfiber 16 µm	
A25 Inorganic microfiber 25 µm	

WA025 Water absorber inorganic microfiber 25 µm

Element Δp **N** 20 bar

Execution **P01** MP Filtri standard
P02 With internal tube for low flow rate
Pxx Customized

FILTER ELEMENT

Element series and size **CU950** Configuration example: **CU950** **3** **A10** **A** **N** **P01**

Element length **3**

Filter series and size

LMP952 Nr. 2 filter elements
LMP953 Nr. 3 filter elements
LMP954 Nr. 4 filter elements

Filtration rating (filter media)

A03 Inorganic microfiber 3 µm	M25 Wire mesh 25 µm
A06 Inorganic microfiber 6 µm	M60 Wire mesh 60 µm
A10 Inorganic microfiber 10 µm	M90 Wire mesh 90 µm
A16 Inorganic microfiber 16 µm	
A25 Inorganic microfiber 25 µm	

WA025 Water absorber inorganic microfiber 25 µm

Seals **A** NBR **V** FPM

Element Δp **N** 20 bar

Execution **P01** MP Filtri standard
Pxx Customized

CLOGGING INDICATORS

See page 726

DEA Electrical differential pressure indicator	DLE Electrical / visual differential pressure indicator
DEM Electrical differential pressure indicator	DTA Electronic differential pressure indicator
DEU Electrical differential pressure indicator	DVA Visual differential pressure indicator
DLA Electrical / visual differential pressure indicator	DVM Visual differential pressure indicator

PLUGS

See page 747

T2 Plug

LMP 952-953-954

Dimensions

LMP952

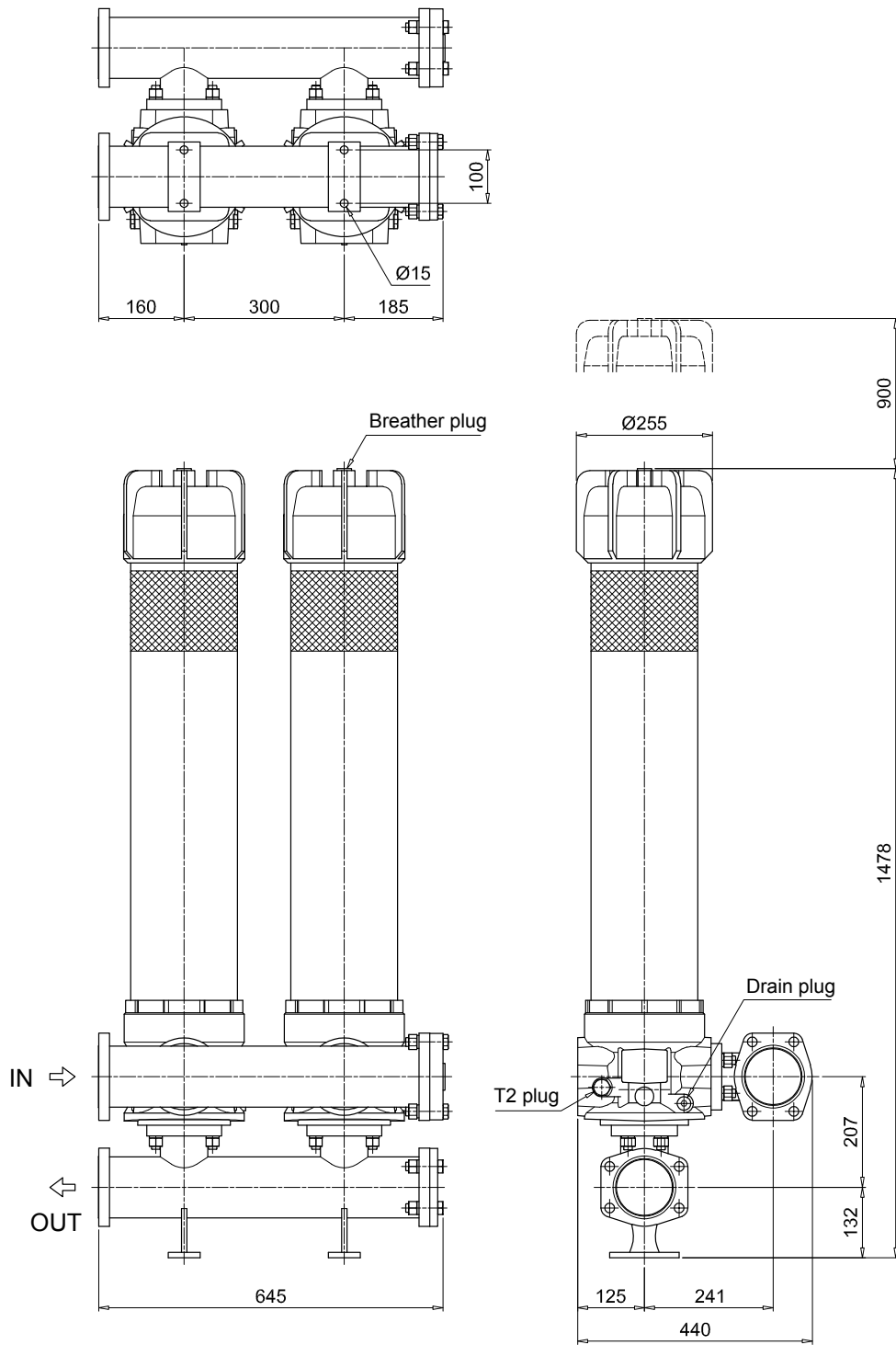

T2 plug = connection for differential pressure indicator

LMP 952-953-954

Dimensions

LMP953

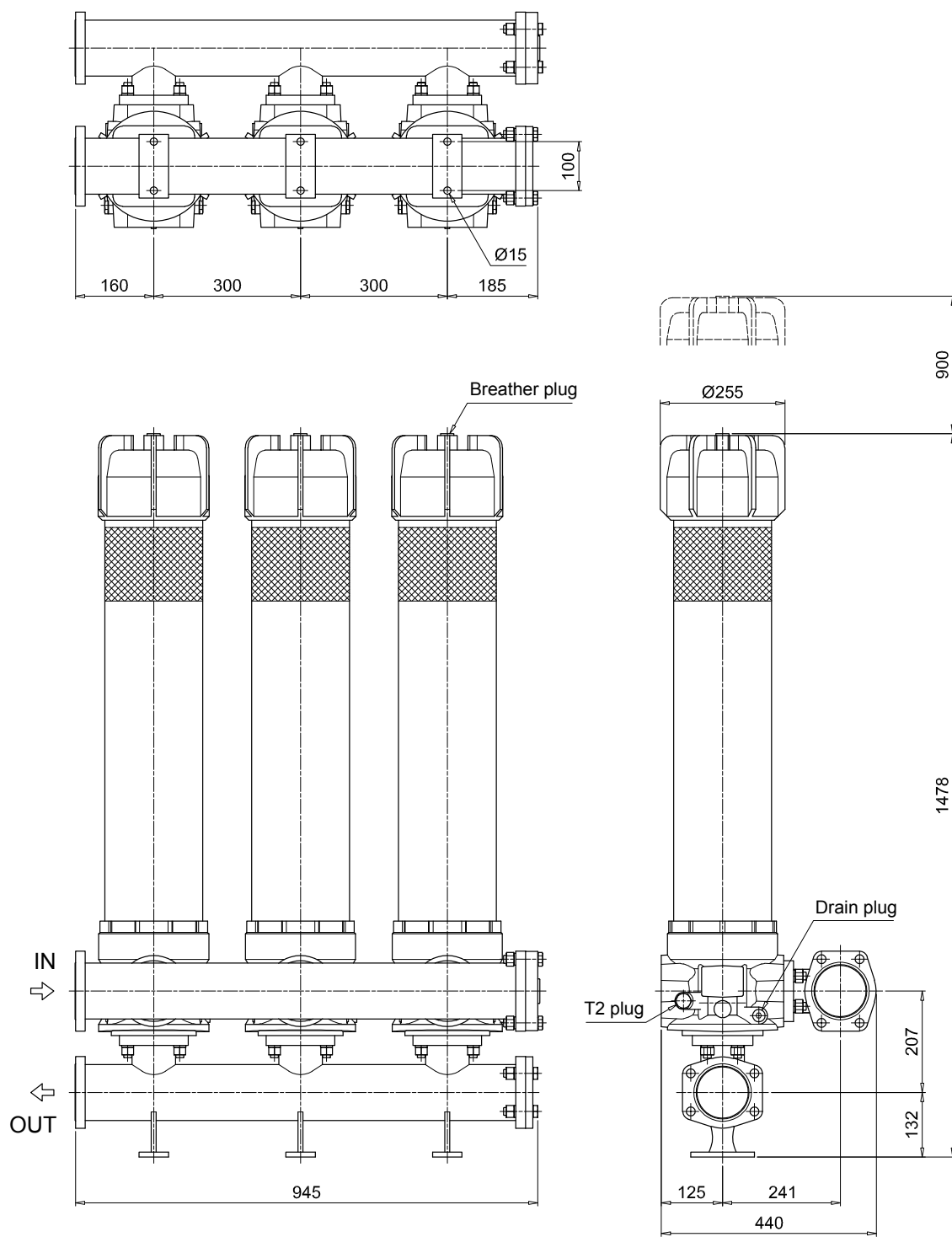

T2 plug = connection for differential pressure indicator

LMP 952-953-954

Dimensions

LMP954

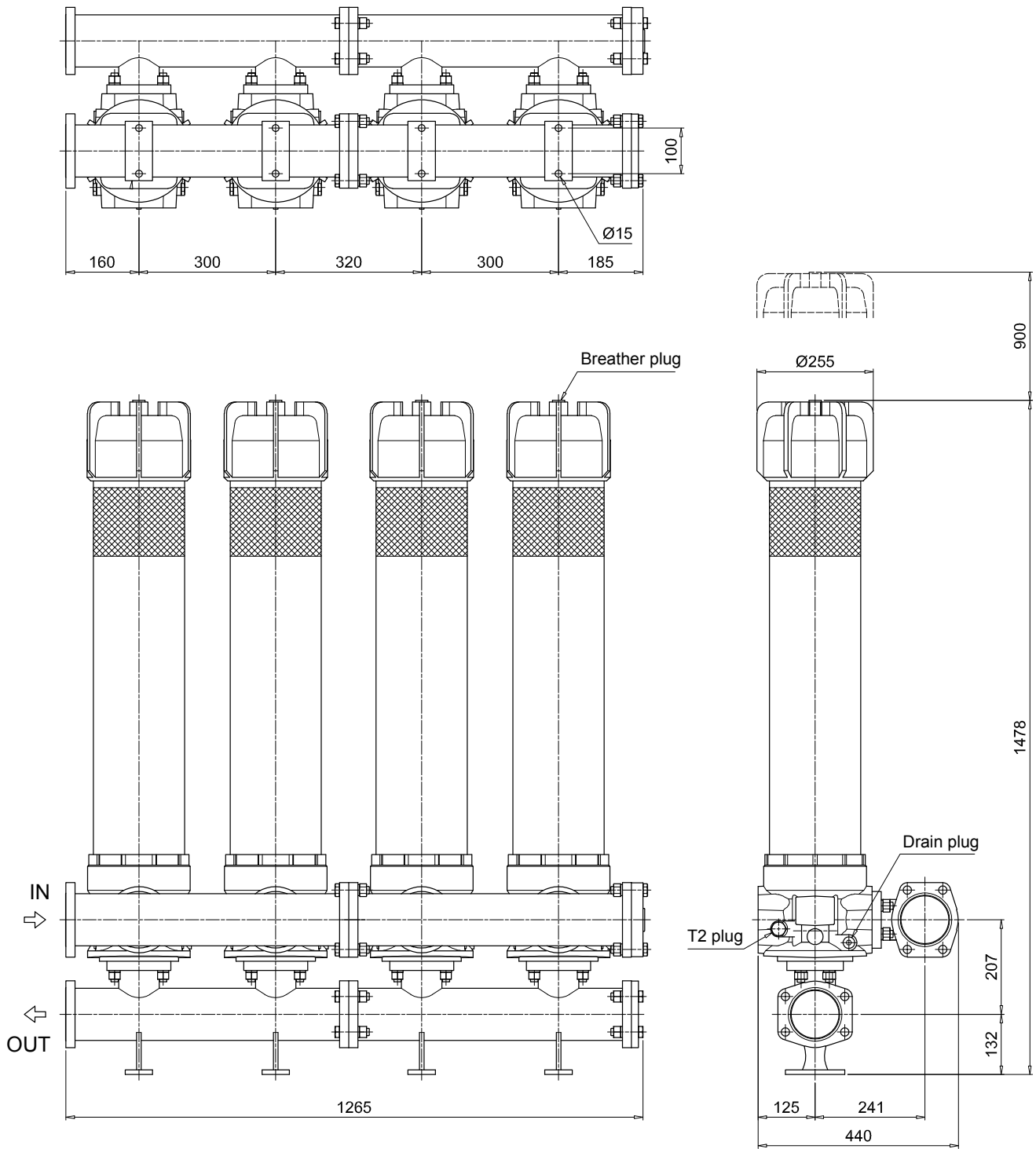

T2 plug = connection for differential pressure indicator

LMP 952-953-954 SPARE PARTS

Order number for spare parts

LMP 952 - 953 - 954

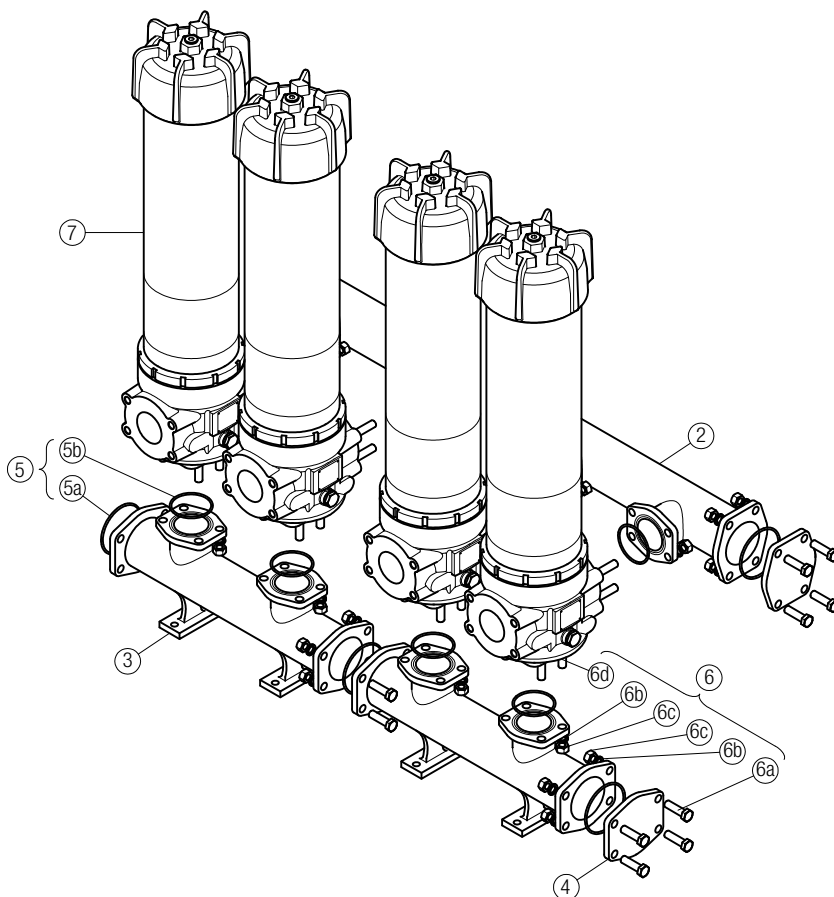

Item 7:
for complete filter code and
spare parts, see
LMP 950 - 951 series chapter

Quantity:
- filter spare parts:
LMP 952 - 2 pcs.
LMP 953 - 3 pcs.
LMP 954 - 4 pcs.

- filter seal kit:
LMP 952 - 2 pcs.
LMP 953 - 3 pcs.
LMP 954 - 4 pcs.

Item:	2		3		4		5 (5a-5b)		6 (6a ÷ 6d)		7	
Filter series	Q.ty	Manifold IN	OUT	4" SAE 3000 psi plugged flange Q.ty	Q.ty	Manifolds seal kit		Q.ty	Threaded fasteners kit		Q.ty	Filter
						NBR	FPM					
LMP 952	1 pc.	01039270	01039271	2 pcs.	01042012	1 pc.	02050404	02050405	1 pc.	02049051	2 pcs.	LMP9513xxF1xxxNP0x
LMP 953	1 pc.	01039337	01039338	2 pcs.		1 pc.	02050404	02050405	1 pc.	02049052	3 pcs.	
LMP 954	2 pcs.	01039270	01039271	2 pcs.		1 pc.	02050406	02050407	1 pc.	02049053	4 pcs.	

CLOGGING INDICATORS LOW & MEDIUM PRESS. FILTERS

Designation & Ordering code

DIFFERENTIAL PRESSURE INDICATORS

Series	Configuration example 1:	DE	M	20	H	F	50	P01	
DE Electrical differential pressure indicator	Configuration example 2:	DE	U	50	V	A	50	P01	UL
DL Electrical/Visual differential pressure indicator	Configuration example 3:	DL	E	50	V	A	71	P01	
DT Electronic differential pressure indicator	Configuration example 4:	DT	A	20	H	F	70	P01	
DV Visual differential pressure indicator	Configuration example 5:	DV	M	50	V			P01	

Type	DE	DL	DT	DV
A Standard type	•	•	•	A With automatic reset
M With wired electrical connection	•	-	-	M With manual reset
U Standard type 210 bar, UL certified	•	-	-	S With automatic reset
E For high power supply	-	•	-	
S Compact version	•	-	-	

Pressure setting	DEA	DEM	DEU	DES	DLA	DLE	DTA	DVA	DVM	DVS
12 1.2 bar	•	•	-	•	•	•	•	•	•	•
20 2.0 bar	•	•	•	-	•	•	•	•	•	-
25 2.5 bar	-	-	-	-	-	-	-	-	-	•
40 4.0 bar	-	-	-	•	-	-	-	-	-	•
50 5.0 bar	•	•	•	-	•	•	•	•	•	-

Seals	DEA	DEM	DEU	DES	DL	DT	DVA	DVM	DVS
H HNBR	•	•	-	•	•	•	•	•	•
V FPM	•	•	•	-	•	•	•	•	-

Thermostat	DEA	DEM	DEU	DES	DLA	DLE	DT
A Without thermostat	•	•	•	•	•	•	-
F With thermostat	-	•	-	-	-	•	•

Electrical connections	DEA	DEM	DEU	DES	DLA	DLE	DT
10 Connection AMP Superseal series 1.5	-	•	-	•	-	-	-
20 Connection AMP Timer Junior	-	•	-	-	-	-	-
30 Connection Deutsch DT-04-2-P	-	•	-	•	-	-	-
35 Connection Deutsch DT-04-3-P	-	•	-	-	-	-	-
50 Connection EN 175301-803	•	-	•	-	-	•	-
51 Connection EN 175301-803, transparent base with lamps 24 Vdc	-	-	-	-	•	-	-
52 Connection EN 175301-803, transparent base with lamps 110 Vdc	-	-	-	-	•	-	-
70 Connection IEC 61076-2-101 D (M12)	-	-	-	-	-	-	•
71 Connection IEC 61076-2-101 D (M12), black base with lamps 24 Vdc	-	-	-	-	•	-	-
80 Connection Stud #10-32 UNF	-	-	-	•	-	-	-

Option
P01 MP Filtri standard
Pxx Customized

Certifications	DEU	OTHERS
Without	-	•
UL UL certification	•	-

PLUGS

Series	Configuration example	T2	H
T2 Plug			
T4 Plug			

Seals	T2	T4
A NBR	-	•
H HNBR	•	-
V FPM	•	-