

# LMP 210-211

Maximum working pressure up to 6 MPa (60 bar) - Flow rate up to 365 l/min



## INSTALLATION, SERVICE AND MAINTENANCE MANUAL AND SAFETY INSTRUCTIONS



LMP210



LMP211

Please scan or click the QR codes to get updated electronic version of the related document.



*For all the QR codes: Scan or click me!*

# LMP 210-211 GENERAL INFORMATION

## Description

## Technical data

### Low & Medium Pressure filters

**Maximum working pressure up to 6 MPa (60 bar)**  
**Flow rate up to 365 l/min**

LMP210 is a range of versatile low pressure filter for transmission, protection of sensitive components in low pressure hydraulic systems and filtration of the coolant into the machine tools. They are also suitable for the off-line filtration of small reservoirs. They are directly connected to the lines of the system through the hydraulic fittings.

#### Available features:

- Flanged connections up to 1 1/2", for a maximum flow rate of 365 l/min (LMP210)
- Female threaded connections up to 1 1/2", for a maximum return flow rate of 365 l/min (LMP211)
- Fine filtration rating, to get a good cleanliness level into the system
- Water removal elements, to remove the free water from the hydraulic fluid. For further information, see the Contamination Management document and the dedicate leaflet.
- Bypass valve, to relieve excessive pressure drop across the filter media
- Visual, electrical and electronic differential clogging indicators

#### Common applications:

Delivery lines, in any low pressure industrial equipment or mobile machines

### Filter housing materials

- Head: Aluminium
- Bowl: Cathaporetic painted steel
- Bypass valve: AISI 304 - Polyamide

### Pressure

- Test pressure: 9 MPa (90 bar)
- Min. Burst pressure: 18 MPa (180 bar)
- Pulse pressure fatigue test: 1 000 000 cycles with pressure from 0 to 6 MPa (60 bar)

### Bypass valve

- Opening pressure 0.35 MPa (3.5 bar)  $\pm 10\%$
- Other opening pressures on request.

### Filter element features

Filter <b>LMP 210-211</b>		Filter element <b>CU</b>	
<b><math>\Delta p</math> Element type</b>			
Element media	Construction	$\Delta p$ Series	$\Delta p$
A - Microfiber	Standard	N	20 bar
M - Wire mesh	Standard	N	20 bar
P - Paper	Standard	N	20 bar
<i>Please see ordering code tables to check element <math>\Delta p</math> series availability based on filter features.</i>			
<b>Flow direction through the filter element:</b> From OUT to IN			

### Seals

- Standard NBR series A
- Optional FPM series V

### Connections

Inlet/Outlet In-Line

### Temperature

From -25 °C to +110 °C

### Note

LMP 210 - 211 filters are provided for vertical mounting

## Weights [kg] and volumes [dm<sup>3</sup>]

Filter series	Weights [kg]			Volumes [dm <sup>3</sup> ]				
	Length	1	2	3	Length	1	2	3
<b>LMP 210-211</b>		3.10	4.80	6.40		1.60	2.10	2.80

# GENERAL INFORMATION LMP 210-211

Flow rates [l/min]

Filter series	Length	Filter element design - N Series									
		A03	A06	A10	A16	A25	M25	M60	M90	P10	P25
LMP 210	1	106	130	190	200	221	286	287	287	261	265
	2	153	175	220	237	249	288	289	290	265	269
	3	204	214	248	260	265	289	290	291	277	281
LMP 211	1	118	149	227	240	269	358	359	360	324	330
	2	178	207	268	292	307	361	362	363	329	335
	3	247	260	306	323	329	362	363	364	345	351

## Maximum flow rate for a complete low and medium pressure filter with a pressure drop $\Delta p = 0.7$ bar.

The reference fluid has a kinematic viscosity of 30 mm<sup>2</sup>/s (cSt) and a density of 0.86 kg/dm<sup>3</sup>.

For different pressure drop or fluid viscosity we recommend to use our selection software available on [www.mpfiltri.com](http://www.mpfiltri.com).

You can also calculate the right size using the formulas present on the FILTER SIZING paragraph at the beginning of the full catalogue or at the beginning of the filter family brochure. Please, contact our Sales Department for further additional information.

## Hydraulic diagram

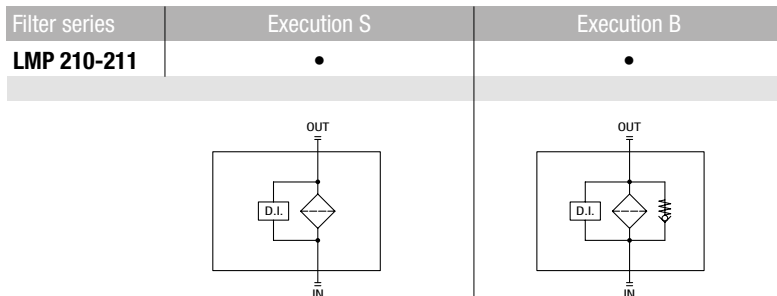

## Pressure drop

Filter housings  
 $\Delta p$  pressure drop

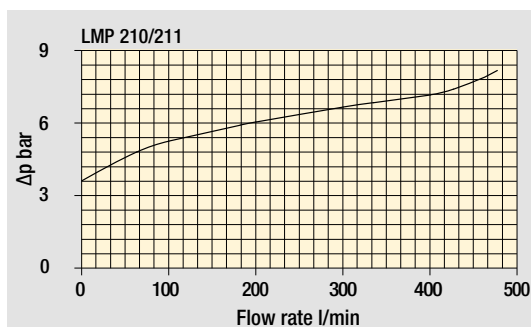
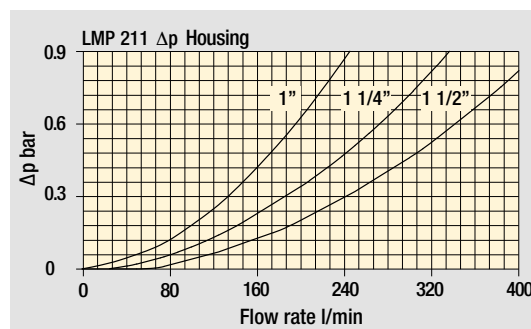
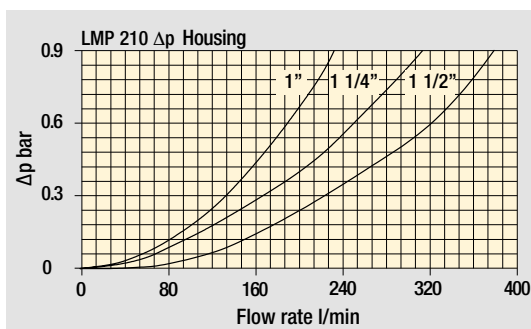

Bypass valve  
pressure drop

The curves are plotted using mineral oil with density of 0.86 kg/dm<sup>3</sup> in compliance with ISO 3968.  $\Delta p$  varies proportionally with density.

# LMP 210

## Designation & Ordering code

### COMPLETE FILTER

Series and size **LMP210** Configuration example: **LMP210** **3** **B** **A** **F1** **A10** **N** **P01**

Length **1** | **2** | **3**

Bypass valve **S** Without bypass | **B** With bypass 3.5 bar

Seals and treatments **A** NBR | **V** FPM | **E** EPDM

Connections **F1** 1" SAE 3000 psi/M | **F2** 1 1/4" SAE 3000 psi/M | **F3** 1 1/2" SAE 3000 psi/M | **F4** 1" SAE 3000 psi/UNC | **F5** 1 1/4" SAE 3000 psi/UNC | **F6** 1 1/2" SAE 3000 psi/UNC

Filtration rating (filter media)

<b>A03</b> Inorganic microfiber 3 µm	<b>M25</b> Wire mesh 25 µm
<b>A06</b> Inorganic microfiber 6 µm	<b>M60</b> Wire mesh 60 µm
<b>A10</b> Inorganic microfiber 10 µm	<b>M90</b> Wire mesh 90 µm
<b>A16</b> Inorganic microfiber 16 µm	<b>P10</b> Resin impregnated paper 10 µm
<b>A25</b> Inorganic microfiber 25 µm	<b>P25</b> Resin impregnated paper 25 µm

**WA025** Water absorber inorganic microfiber 25 µm

Element Δp **N** 20 bar

Execution **P01** MP Filtri standard  
**Pxx** Customized

### FILTER ELEMENT

Element series and size **CU210** Configuration example: **CU210** **3** **A10** **A** **N** **P01**

Element length **1** | **2** | **3**

Filtration rating (filter media)

<b>A03</b> Inorganic microfiber 3 µm	<b>M25</b> Wire mesh 25 µm
<b>A06</b> Inorganic microfiber 6 µm	<b>M60</b> Wire mesh 60 µm
<b>A10</b> Inorganic microfiber 10 µm	<b>M90</b> Wire mesh 90 µm
<b>A16</b> Inorganic microfiber 16 µm	<b>P10</b> Resin impregnated paper 10 µm
<b>A25</b> Inorganic microfiber 25 µm	<b>P25</b> Resin impregnated paper 25 µm

**WA025** Water absorber inorganic microfiber 25 µm

Seals and treatments **A** NBR | **V** FPM | **E** EPDM

Element Δp **N** 20 bar

Execution **P01** MP Filtri standard  
**Pxx** Customized

### CLOGGING INDICATORS

See page 784

**DEA** Electrical differential pressure indicator

**DEM** Electrical differential pressure indicator

**DEU** Electrical differential pressure indicator

**DLA** Electrical / visual differential pressure indicator

**DLE** Electrical / visual differential pressure indicator

**DTA** Electronic differential pressure indicator

**DTI** I-O Link electronic differential pressure indicator

**DVA** Visual differential pressure indicator

**DVM** Visual differential pressure indicator

### PLUGS

See page 807

**T2** Plug

LMP210	
Filter length	H [mm]
<b>1</b>	362
<b>2</b>	492
<b>3</b>	633
Connections	R
<b>F1 - F2 - F3</b>	M8
<b>F4 - F5 - F6</b>	5/16" UNC

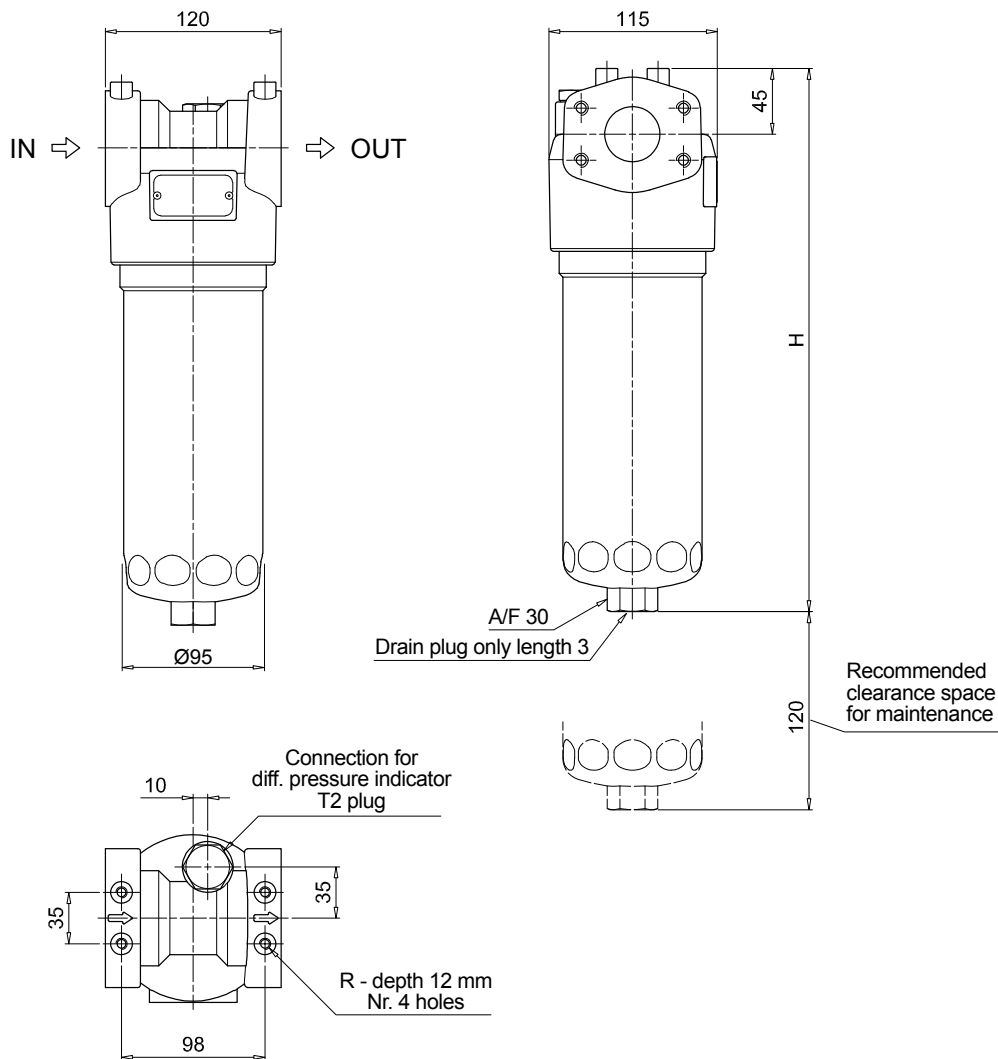

# LMP 211

## Designation & Ordering code

### COMPLETE FILTER

Series and size **LMP211** Configuration example: **LMP211** **3** **B** **A** **D** **6** **A10** **N** **P01**

**Length**  
**1** | **2** | **3** |

**Bypass valve**  
**S** Without bypass | **B** With bypass 3.5 bar

**Seals and treatments**  
**A** NBR | **E** EPDM  
**V** FPM | **C** CR

**Connections**  
**A** G 1"  
**B** G 1 1/4"  
**C** G 1 1/2"  
**D** 1" NPT  
**E** 1 1/4" NPT  
**F** 1 1/2" NPT  
**G** SAE 16 - 1 5/16" - 12 UN  
**H** SAE 20 - 1 5/8" - 12 UN  
**I** SAE 24 - 1 7/8" - 12 UN

**Connection for differential pressure indicator**  
**6** With plugged connection

**Filtration rating (filter media)**

<b>A03</b> Inorganic microfiber 3 µm	<b>M25</b> Wire mesh 25 µm
<b>A06</b> Inorganic microfiber 6 µm	<b>M60</b> Wire mesh 60 µm
<b>A10</b> Inorganic microfiber 10 µm	<b>M90</b> Wire mesh 90 µm
<b>A16</b> Inorganic microfiber 16 µm	<b>P10</b> Resin impregnated paper 10 µm
<b>A25</b> Inorganic microfiber 25 µm	<b>P25</b> Resin impregnated paper 25 µm

**WA025** Water absorber inorganic microfiber 25 µm

**Element Δp**  
**N** 20 bar

**Execution**  
**P01** MP Filtri standard  
**Pxx** Customized

### FILTER ELEMENT

Element series and size **CU210** Configuration example: **CU210** **3** **A10** **A** **N** **P01**

**Element length**  
**1** | **2** | **3** |

**Filtration rating (filter media)**

<b>A03</b> Inorganic microfiber 3 µm	<b>M25</b> Wire mesh 25 µm
<b>A06</b> Inorganic microfiber 6 µm	<b>M60</b> Wire mesh 60 µm
<b>A10</b> Inorganic microfiber 10 µm	<b>M90</b> Wire mesh 90 µm
<b>A16</b> Inorganic microfiber 16 µm	<b>P10</b> Resin impregnated paper 10 µm
<b>A25</b> Inorganic microfiber 25 µm	<b>P25</b> Resin impregnated paper 25 µm

**WA025** Water absorber inorganic microfiber 25 µm

**Seals and treatments**  
**A** NBR | **E** EPDM  
**V** FPM | **C** CR

**Element Δp**  
**N** 20 bar

**Execution**  
**P01** MP Filtri standard  
**Pxx** Customized

### CLOGGING INDICATORS

See page 784

<b>DEA</b> Electrical differential pressure indicator
<b>DEM</b> Electrical differential pressure indicator
<b>DEU</b> Electrical differential pressure indicator
<b>DLA</b> Electrical / visual differential pressure indicator
<b>DLE</b> Electrical / visual differential pressure indicator

<b>DTA</b> Electronic differential pressure indicator
<b>DTI</b> I-O Link electronic differential pressure indicator
<b>DVA</b> Visual differential pressure indicator
<b>DVM</b> Visual differential pressure indicator

### PLUGS

See page 807

<b>T2</b> Plug
----------------

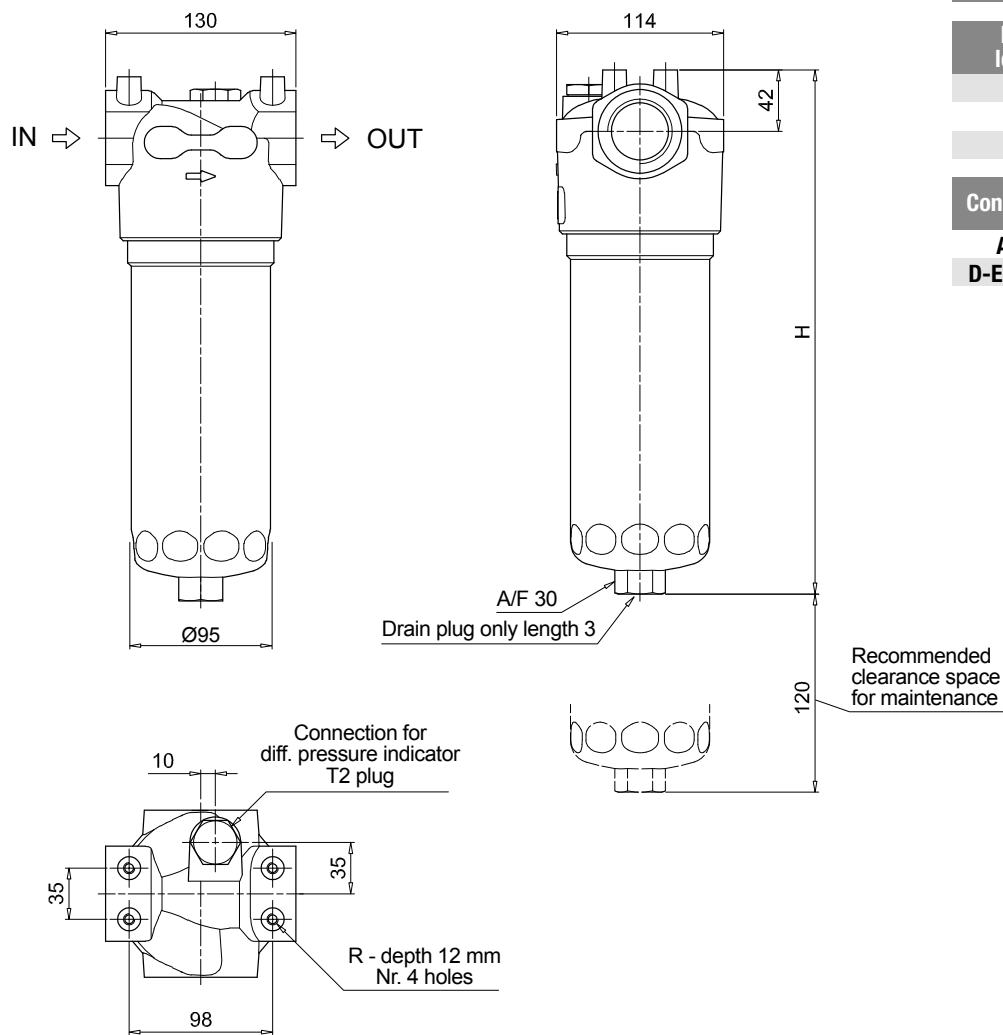

LMP211	
Filter length	H [mm]
1	358
2	488
3	629
Connections	R
A-B-C	M8
D-E-F-G-H-I	5/16" UNC

# LMP 210-211 SPARE PARTS

Order number for spare parts

LMP 210

LMP 211

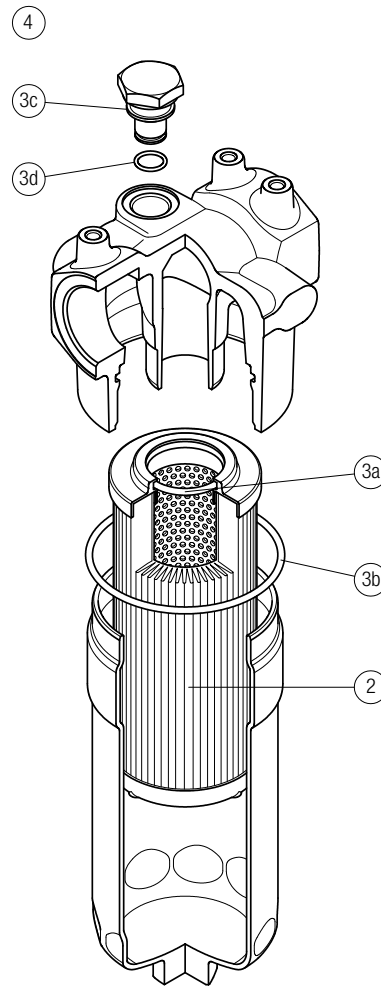
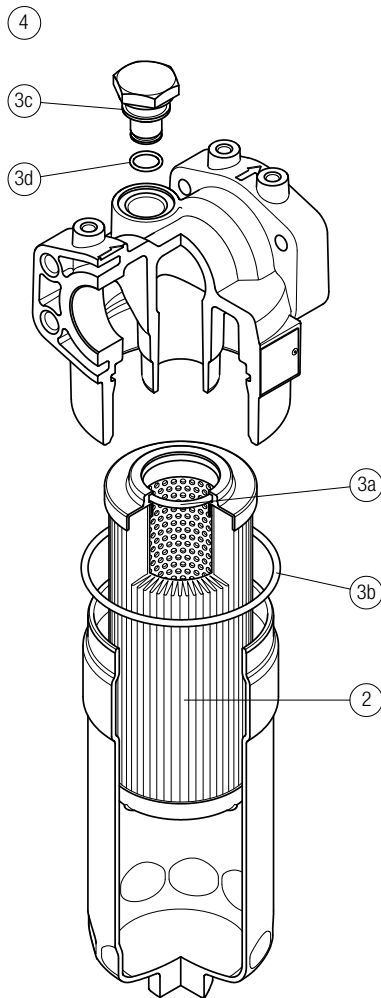

Item:	Q.ty: 1 pc.		Q.ty: 1 pc.		Q.ty: 1 pc.	
Filter series	Filter element	Seal Kit code number		Indicator connection plug		
LMP 210-211	See order table	NBR	FPM	NBR	FPM	
	2	02050435	02050436	T2H	T2V	
		3 (3a ÷ 3d)		4		