

LMP 124 series

MULTI PORT

Maximum working pressure up to 8 MPa (80 bar) - Flow rate up to 200 l/min



Step 1 Select "FILTERS"

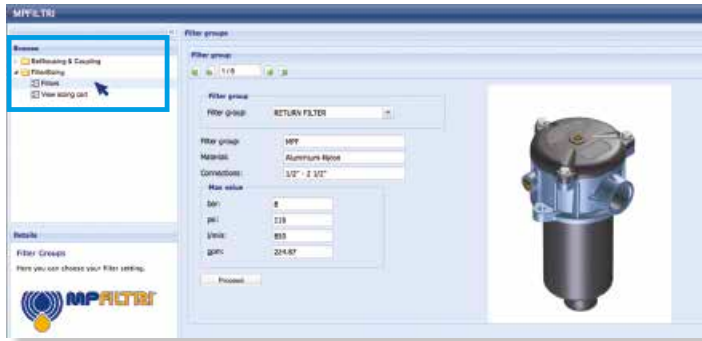

Step 2 Choose filter group (Return Filter, Pressure Filter, etc.)



Step 3 Choose filter type (MPF, MPT, etc.) in function of the max working pressure and the max flow rate



Step 4 Push "PROCEED"

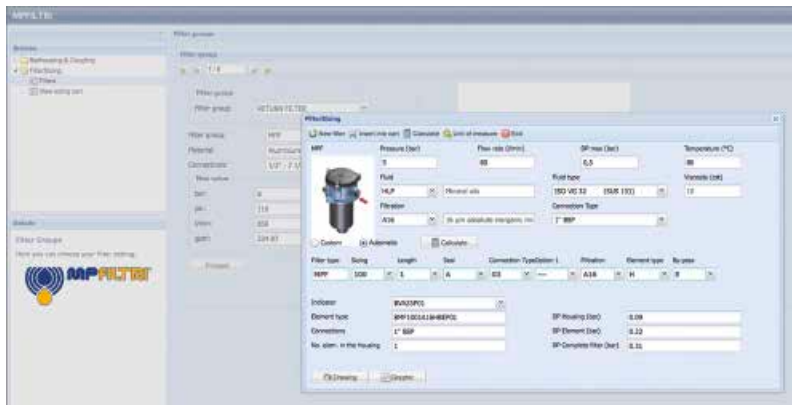
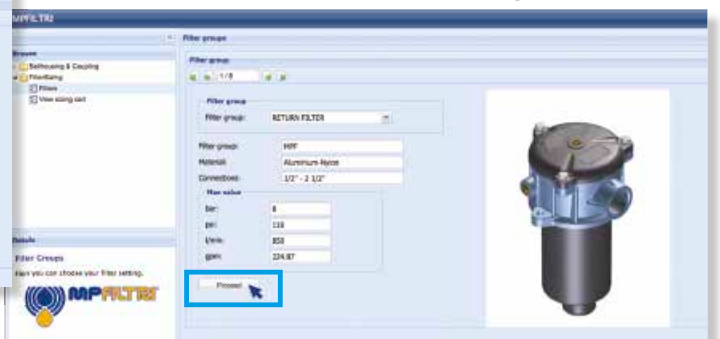

Step 5

Insert all application data to calculate the filter size following the sequence:

- working pressure
- working flow rate
- working pressure drop
- working temperature
- fluid material and fluid type
- filtration media
- connection type

Step 6

Push "CALCULATE" to have result; in case of any mistake, the system will advise which parameter is out of range to allow to modify/adjust the selection

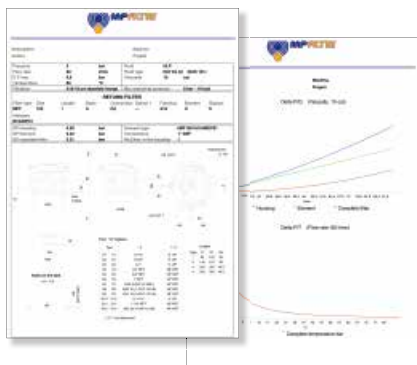
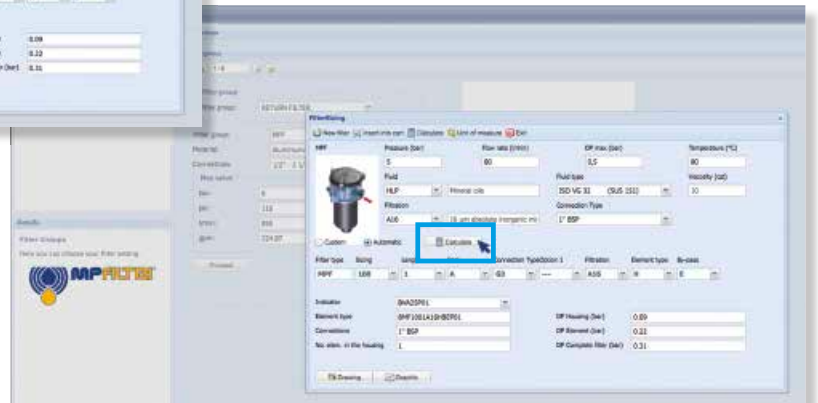

Step 7

Download PDF Datasheet "Report.aspx" pushing the button "Drawing"

Description

Technical data

Return / Suction filter

In-line

Maximum working pressure up to 8 MPa (80 bar)
Flow rate up to 200 l/min

LMP124 is a range of return/suction filters for hydraulic systems with two or more circuits (both open and closed loops). They are able to provide pressurized oil cleaned by fine filtration to the feed pump of the hydrostatic systems.

They are directly connected to the lines of the system through the hydraulic fittings.

Available features:

- Female threaded connections up to 1", for a maximum return flow rate of 200 l/min
- Fine filtration rating, to get a good cleanliness level into the reservoir
- Bypass valve to the tank, to relieve excessive pressure drop across the filter media when the return flow is enough higher than the suction flow
- Bypass valve to the suction line with additional suction filter element, to relieve excessive pressure drop across the filter media when the return flow is not enough higher than the suction flow
- De-pressurization valve, to reduce the pressure inside the filter during the maintenance operations
- Visual, electrical and electronic differential clogging indicators

Common applications:

Mobile machines with hydrostatic systems on board.
 (i.e. skid steer loaders, telehandlers, dumpers, road sweepers)

Filter housing materials

- Head: Aluminium
- Housing: Cathaphoresis - Painted Steel
- Bypass valve: Brass - Aluminium

Pressure

- Test pressure: 12MPa (120 bar)
- Burst pressure: 38 MPa (380 bar)
- Pulse pressure fatigue test: 1 000 000 cycles with pressure from 0 to 80 bar (8 MPa)

Bypass valve

- Opening pressure 250 kPa (2.5 bar) ±10%
- Other opening pressures on request.

Δp element type

- Microfibre filter elements - series N - W: 20 bar
- Fluid flow through the filter element from OUT to IN.

Seals

- Standard NBR series A
- Optional FPM series V

Temperature

From -25 °C to +110 °C

Note

LMP124 filters are provided for vertical mounting



Weights [kg] and volumes [dm³]

Filter series	Weights [kg]				Volumes [dm ³]					
	Length	1	2	3	4	Length	1	2	3	4
LMP 124		1.70	1.90	2.20	2.70		0.75	0.81	1.11	1.53

Filter series	Length	Filter element design - N series							
		A03	A06	A10	A16	A25	M25 M60 M90	P10	P25
LMP 124	1	39	41	58	60	69	99	84	85
	2	47	53	68	69	77	99	90	91
	3	59	61	73	77	86	99	92	93
	4	70	78	84	86	93	100	94	95



Maximum flow rate for a complete return/suction filter with a pressure drop $\Delta p = 1.2$ bar.

The reference fluid has a kinematic viscosity of 30 mm²/s (cSt) and a density of 0.86 kg/dm³.

For different pressure drop or fluid viscosity we recommend to use our selection software available on www.mpfiltri.com.

You can also calculate the right size using the formulas present on the FILTER SIZING paragraph at the beginning of the full catalogue or at the beginning of the filter family brochure. Please, contact our Sales Department for further additional information.

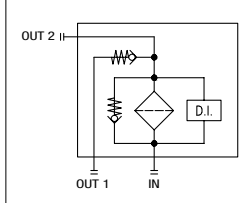
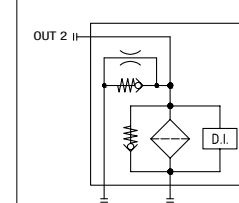
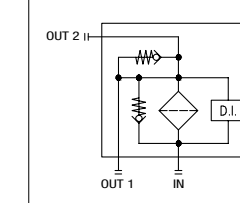
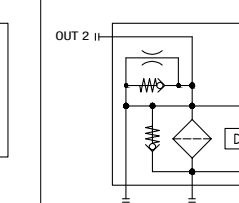
Hydraulic symbols - Multipoint styles

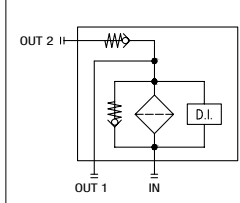
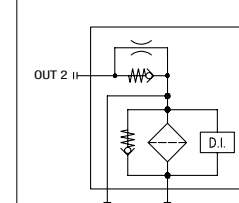
Multipoint	Valves C option	Valves D option	Valves E option	Valves F option
 <p>IN - Return OUT 1 - Tank OUT 2 - Pump</p>				
 <p>IN - Return OUT 1 - Tank OUT 2 - Pump</p>				

Pressure drop

Filter housings Δp pressure drop

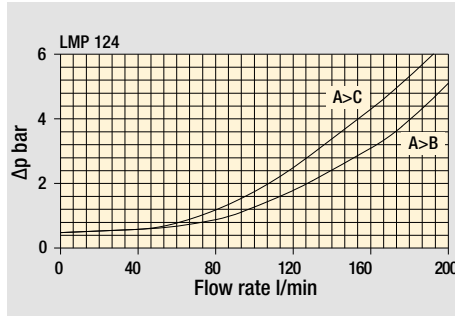

Bypass valve pressure drop

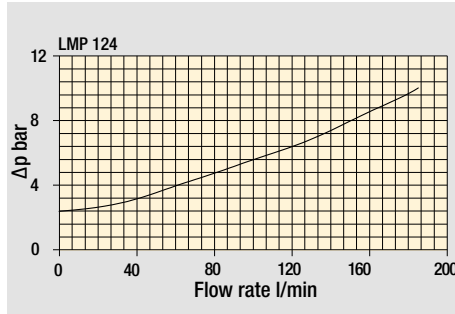

Valves

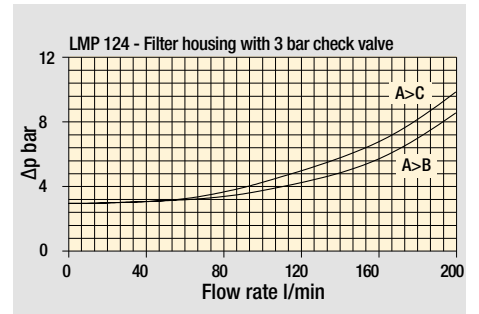
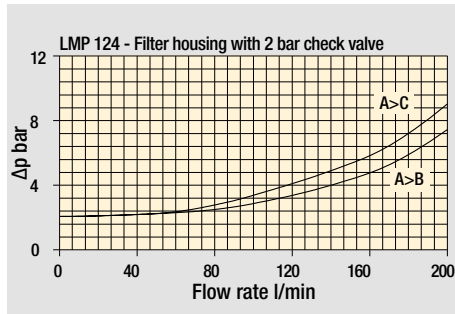

Filter length: 1 - 2 - 3 - 4

STYLE C - D - E - F

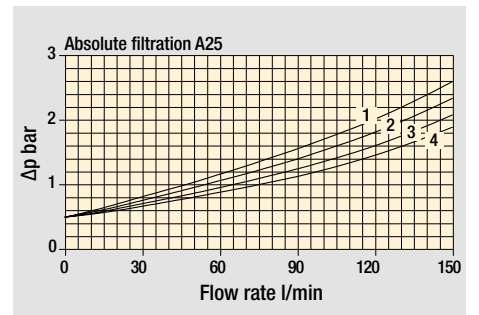
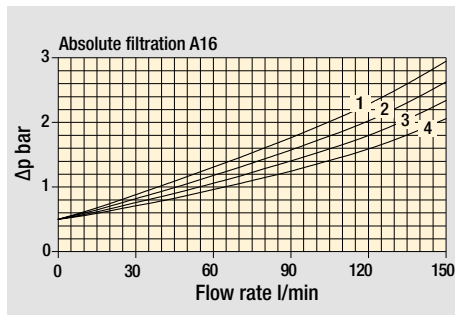
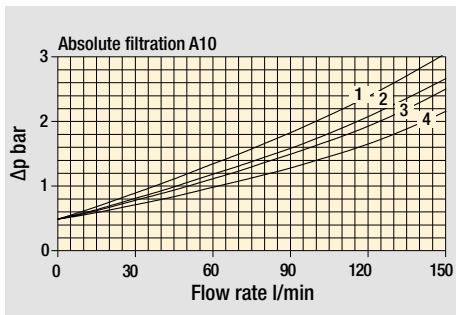

STYLE G - H

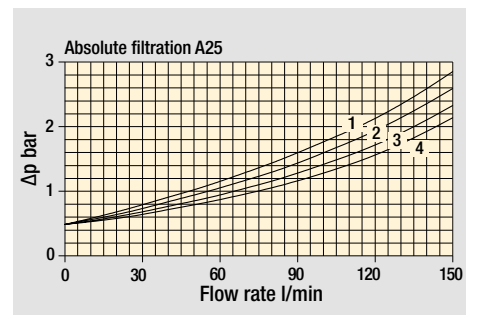
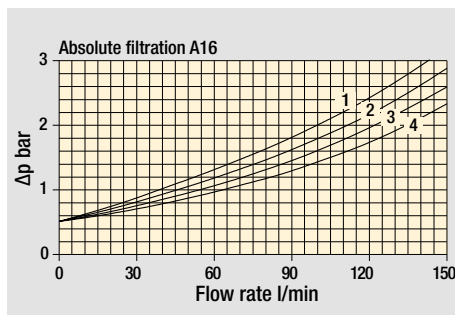
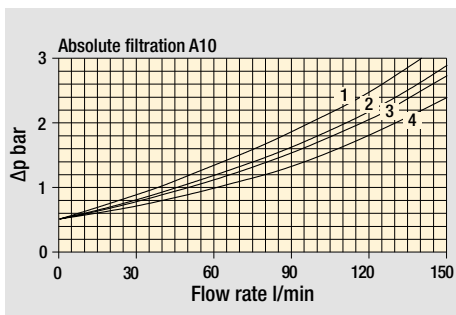

The curves are plotted using mineral oil with density of 0.86 kg/dm^3 in compliance with ISO 3968. Δp varies proportionally with density.

Designation & Ordering code

COMPLETE FILTER

Series and size	Configuration example: LMP124 4 C A F 1 A10 N P01									
LMP124										
Filter length	1 2 3 4									
Hydraulic diagram configuration - see page 268	C D E F G H									
Seals and treatments	Filtration rating									
A NBR	Axx	Mxx	Pxx							
V FPM	•	•	•							
W NBR compatible with fluids HFA-HFB-HFC	•	•								
Connections										
B G 1"										
F SAE 16 - 1 5/16" - 12 UN										
Connection for indicator										
1 Without										
2 With connection G 1/8" for clogging indicator										
3 With connection G 1/4" for clogging indicator										
4 With connection for differential indicator										
Filtration rating (filter media)										
A03 Inorganic microfiber 3 µm										
A06 Inorganic microfiber 6 µm										
A10 Inorganic microfiber 10 µm										
A16 Inorganic microfiber 16 µm										
A25 Inorganic microfiber 25 µm										
M25 Wire mesh 25 µm										
M60 Wire mesh 60 µm										
M90 Wire mesh 90 µm										
P10 Resin impregnated paper 10 µm										
P25 Resin impregnated paper 25 µm										
			Element Δp	Execution						
			N 20 bar	P01 MP Filtri standard						
				Pxx Customized						

FILTER ELEMENT

Element series and size	Configuration example: CU110 4 A10 A N P01						
CU110							
Element length	1 2 3 4						
Filtration rating (filter media)							
A03 Inorganic microfiber 3 µm							
A06 Inorganic microfiber 6 µm							
A10 Inorganic microfiber 10 µm							
A16 Inorganic microfiber 16 µm							
A25 Inorganic microfiber 25 µm							
M25 Wire mesh 25 µm							
M60 Wire mesh 60 µm							
M90 Wire mesh 90 µm							
P10 Resin impregnated paper 10 µm							
P25 Resin impregnated paper 25 µm							
Seals	Filtration rating						
A NBR	Axx	Mxx	Pxx				
V FPM	•	•	•				
W NBR compatible with fluids HFA-HFB-HFC	•	•					
			Element Δp	Execution			
			N 20 bar	P01 MP Filtri standard			
				Pxx Customized			

ACCESSORIES

Indicators on Return Line	page			page
BVA Axial pressure gauge	278	BEA Electrical pressure indicator		276
BVR Radial pressure gauge	278	BEM Electrical pressure indicator		276
BVP Visual pressure indicator with automatic reset	279	BET Electrical pressure indicator		276-277
BVQ Visual pressure indicator with manual reset	279	BLA Electrical / visual pressure indicator		277-278
Differential indicators	page			page
DEA Electrical differential indicator	280	DTA Electronic differential indicator		283
DEM Electrical differential indicator	280-281	DVA Visual differential indicator		283
DLA Electrical / visual differential indicator	281-282	DVM Visual differential indicator		283
DLE Electrical / visual differential indicator	282			
Additional features	page			
T2 Plug	284			

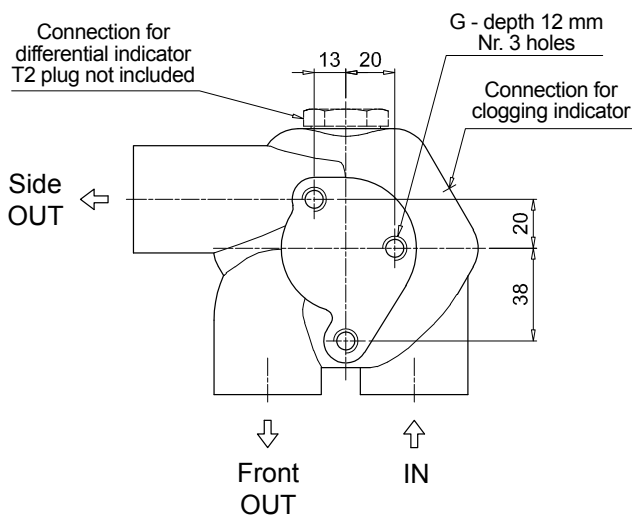
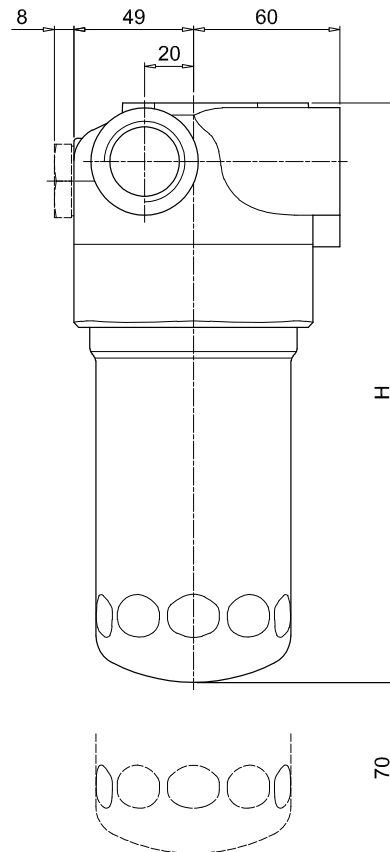
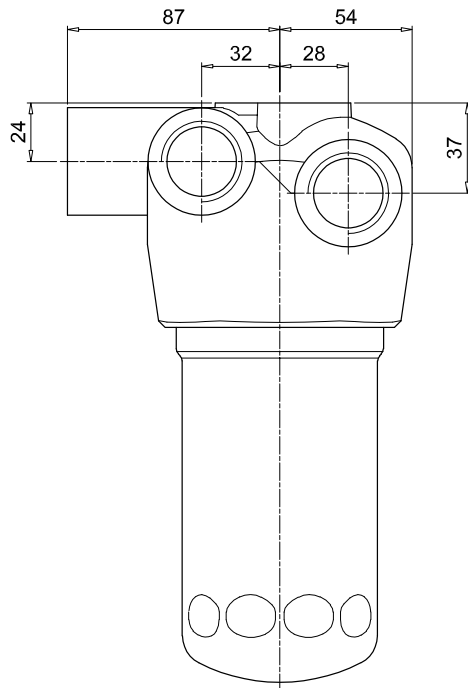

LMP 124	
MULTIPORT	
Filter length	H [mm]
1	182
2	215
3	265
4	365
Connections	R
B	M10
F	3/8" UNC

LMP 124 MULTIPORT

MULTIPORT

Order number for spare parts

LMP 124 MULTIPORT

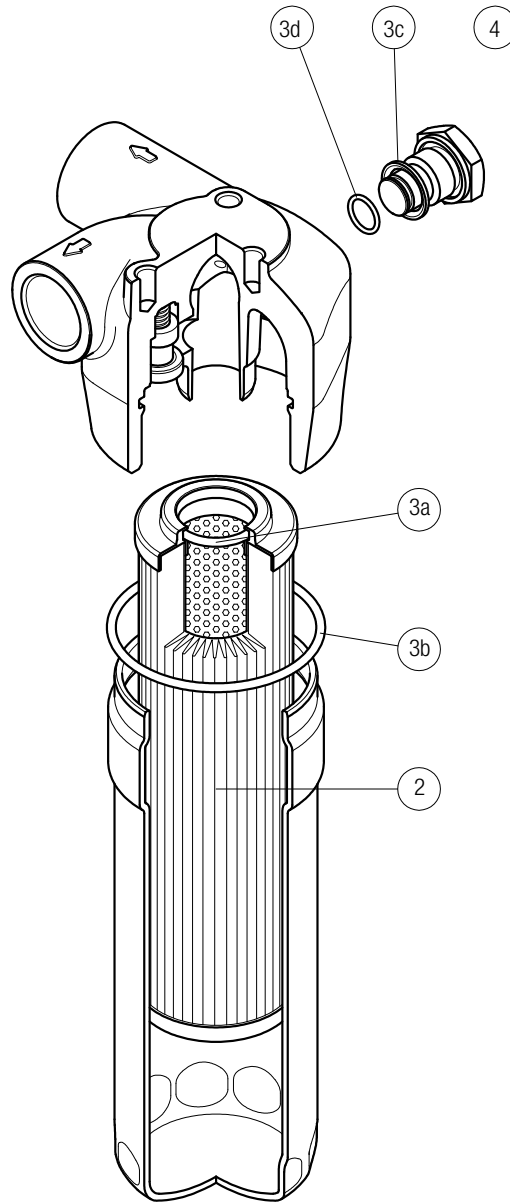

Item:	Q.ty: 1 pc.	Q.ty: 1 pc.		Q.ty: 1 pc.	
Filter series	Filter element	Seal Kit code number		Indicator connection plug	
LMP 124 MULTIPORT	See order table	NBR	FPM	NBR	FPM
	2	3 (3a ÷ 3d)		4	
		02050478	02050479	T2H	T2V